

3588^{-05/020} ^{-15/020}

TEILELISTE

PARTS LIST

LISTE DE PIÈCES

LISTA DE PIEZAS

Diese Teileliste hat für Maschinen
ab nachfolgender Seriennummer Gültigkeit:

This parts list applies to machines
from the following serial numbers onwards:

Cette liste de pièces est valable pour les machines
au numéros de série à partir de:

Esta liste de piezas tiene validez para máquinas
a partir del número de serie siguiente:

2 792 153 →

Alle Informationen und Abbildungen waren zum Zeitpunkt der Druckgebung auf dem neuesten Stand.

Technische Änderungen vorbehalten!

Der Nachdruck, die Vervielfältigung sowie die Übersetzung - auch auszugsweise - aus PFAFF-Teilelisten ist nur mit unserer vorherigen Zustimmung und mit der Quellenangabe gestattet.

At the time of printing, all information and illustrations contained in this document were up to date.

Subject to alteration!

The reprinting, copying or translation of PFAFF Parts lists whether in whole or in part, is only permitted with our previous permission and with written reference to the source.

Au moment de la remise à l'imprimeur, toutes les informations et figures se rapportant à cette machine correspondaient à l'état actuel des connaissances.

Sous réserve de modifications techniques!

Aucune reproduction, polycopie ou traduction - même par extraits - des listes de pièces PFAFF ne peut être effectuée, à condition d'en indiquer l'origine, sans notre autorisation expresse.

Todas las informaciones e ilustraciones de este manual estaban al día en el momento de entregarse para su impresión.

¡ Salvo modificaciones técnicas!

La reimpresión, reproducción y traducción - aunque sólo sea parcial - de las listas de piezas PFAFF sólo está permitida con nuestro permiso previo e indicando la fuente.

**PFAFF Industriesysteme
und Maschinen AG**

Hans-Geiger-Str. 12 - IG Nord

D-67661 Kaiserslautern

0	Wichtiger Hinweis	7
	Important note Avis important Observación importante	
1	Vorwort	8
	Foreword Avant-propos Notas preliminares	
2	Erläuterung der Schlüsselzeichen	9
	Explanation of key markings Explication des symboles Explicaciones de los signos clave	
3	Nähmaschine Sewing machine Tête de machine Máquina de coser	
3.01	Gehäuseteile	11
	Housing sections Parties du corps Piezas del cárter	
3.02	Kopfteile	12
	Needle head parts Pièces de tête Piezas de la cabeza	
3.03	Armteile	15
	Arm parts Pièces de bras Piezas del brazo	
3.04	Grundplattenteile	25
	Bedplate parts Pièces du plateau fondamental Piezas del carter	
4	Tischplatte	36
	Table top Plateau de table Tablero de costure	
5	Gestell mit Anbauteilen	37
	Stand with assembly parts Bâti avec éléments de montage Barrcada con piezas de montaje	
6	X-Y Antrieb	39
	X-Y drive Système de commande X-Y Grupo de accionamiento "X-Y"	

	Seite Page Page Página
7	Stapler45 Stacker Empileur Apilador
8	Umbugger51 Folder Remplieur Grupo dobiador
9	Pneumatische Ausrüstung58 Pneumatic equipment Equipement pneumatique Equipo neumatico
10	Elektrische Ausrüstung Electrical equipment Equipement électrique Equipo eléctrico
10.01	Bedienfeld64 Control panel Panneau de commande Panel de mandos
10.02	Notausschalter und Nähmotor65 Emergency shut-off and sewing motor Interrupteur d'arrêt d'urgence et moteur de machine à coudre Interruptor de emergencia y motor máquina de coser
10.03	Zweihandbedienung66 Operation with both hands Commande à deux mains Manejo a dos manos
10.04	Steuergerät67 Control device Boîte de commande Caja de mandos
10.05	Saugeinrichtung78 Vacuum system Dispositif d'aspiration Dispositivo de aspiración
10.06	Stoffrückhaltevorrichtung79 Workpiece retainer Dispositif de rétension du tissu Dispositivo de retención del material
11	Verkleidung80 Cover panel Carters Revestimiento

	Seite Page Page Página
12 Garnrollenständer	85
Reel stands	
Porte-bobines	
Portacarretes	
13 Einstellehren	86
Adjustment gauges	
Galibres	
Galibres de ajuste	
14 Schmiermittel-Übersicht	87
Overview of lubricants	
Tableau de lubrifiants	
Tabla de lubricantes	
15 Abweichende Teile der PFAFF 3588-15/020	88
Different parts for PFAFF 3588-15/020	
Pièces divergentes de la PFAFF 3588-15/020	
Piezas de la PFAFF 3588-15/020 que son diferentes	
16 Optionen	
Options	
Options	
Opciones	
16.01 Höhenverstellung für Gestell	96
Vertical adjustment for frame	
Réglage de la hauteur du bâti	
Regulación de la altura del bastidor	
16.02 Transportrolle	101
Feed roller	
Galet d'entraînement	
Rodillo el transporte	
16.03 Anbausatz für Programmerkennung	102
Add-on kit for program identification	
Kit pour reconnaissance de programme	
Kit para identificación del programa	
16.04 Anbausatz für Magnet	103
Add-on kit for solenoid	
Jeu de pièces adaptables pour electro-aimant	
Juego de piezas acoptables para Electroimán	
16.05 Bausatz für breiten Saum	104
Kit for wide hem	
Kit pour ourlet large	
Juego de montaje para dobladillo ancho	
16.06 Ablagebox	105
Collection box	
Boîte à prince	
Caja de apilado	

	Seite Page Page Página
16.07 Halter für Laser	105
Laser part set holder	
Support à laser	
Sujeción de laser	
16.08 Fußtaster mit Leitung	106
Foot control with cord	
Interrupteur au pied, avec cable	
Interruptor de pie, con cable	
16.09 Teilesatz vollst. (Standardausführung)	107
Part set assy. (Standard version)	
Jeu de pièces comp. (Version standard)	
Juego de piezas compl. (tipo estándar)	
16.10 Teilesatz für Etiketten	111
Part set for labels	
Jeu de pièces pour les étiquettes	
Juego de piezas para etiquetas	
16.11 Teilesatz für Multisize	115
Multi-size part set	
Jeu de pièces pour multi-taille	
Juego de piezas para tailas múltiples	
16.12 Teilesatz für Patten	117
Part set for flaps	
Jeu de pièces pour pattes	
Juego de piezas para solapas de bolsillo	
16.13 Teilesatz für variablen Näh Schlitz	121
Part set for variable sewing slot	
Jeu de pièces pour fente variable de couture	
Juego de piezas para ranura variable de costura	
16.14 Anbausatz für vorgebuggte Taschen	123
Add-on kit pro-folded-pockets	
Kit pour poches-conformées	
Conjunto de piezas para bolsillo predoblado	
16.15 Anbausatz für Cargotaschenabweiser	124
Add-on kit for cargo pocket deflector	
Kit pour déviateur poche cargo	
Kit para desviador do bolsillo de fuelle	
16.16 Adapter für Teilesätze der PFAFF 3568	129
Gauge parts adapter for the PFAFF 3568	
Adapteur de kits pour la PFAFF 3568	
Adaptador para jurgos de piezas de la PFAFF 3568	
17 Index (Teilenummern / Seitenzahlen)	130
Index (part numbers / page numbers)	
Index (numéros de pièces, de pages)	
Index (números de pieza / números de página)	

Achtung!



Wir machen ausdrücklich darauf aufmerksam, daß Ersatz- und Zubehörteile, die nicht von uns geliefert werden, auch nicht von uns geprüft und freigegeben sind. Der Einbau und / oder die Verwendung solcher Produkte kann daher u. Umständen konstruktiv vorgegebene Eigenschaften Ihrer Maschine negativ verändern. Für Schäden, die durch die Verwendung von Nicht-Originalteilen entstehen, übernehmen wir keine Haftung!

Caution!



We warn you expressively that spare parts and accessories that are not supplied by us are not tested and released by us. Fitting or using these products may therefore have negative influences on features that depend on the machine design. We are not liable for any damage caused by the use of non-Pfaff parts!

Attention!



Nous attirons expressément votre attention sur le fait que les pièces de rechange et accessoires qui n'ont pas été livrés par nous n'ont pas non plus été contrôlés et agréés par nous. C'est pourquoi le montage et/ou l'utilisation de telles pièces peut éventuellement entraîner l'altération des caractéristiques de construction de votre machine. Par conséquent, nous n'assumons aucune responsabilité pour les dommages causés par l'emploi de pièces qui ne sont pas d'origine!

¡Atención!



Se hace observar que en el caso de piezas de recambio y accesorios que no hayan sido suministrados por nosotros, quiere decir que non han sido sometidas por nuestra parte a un control y que no se les ha dado el visto bueno. Por esta razón, el montaje y/o empleo de tales productos puede repercutir negativamente en las características previstas en su máquina. ¡Para los daños que eventualmente pudiesen presentarse al utilizar piezas no originales, no asumimos ninguna garantía!

- Die Seriennummer der Maschine, für die diese Teileliste Gültigkeit hat, ist auf der Titel-seite aufgeführt.
 - Alle Teile sind so abgebildet, wie sie in der Maschine funktionsmäßig zusammengehören.
 - Gestrichelt dargestellte Teile zeigen angrenzende Teile aus anderen Funktionsgruppen.
 - Im oberen Teil der Bildseiten befindet sich eine Gesamtansicht der Maschine .
 - Der Einbauort der dargestellten Teile wird durch eine gerasterte Fläche gekennzeichnet.
 - Einrahmungen auf den Bildseiten zeigen, aus welchen Einzelteilen sich die Gruppenteile zusammensetzen.
 - Die auf den Bildseiten verwendeten Schlüsselzeichen (; 2 ; 3 usw.) sind im Kapitel "Erläuterungen der Schlüsselzeichen" aufgelistet.
-
- The serial number of the machine to which this parts list applies is indicated on the cover page.
 - All parts are illustrated in function groups with the parts which they function together with in the machine.
 - Parts illustrated with broken lines are parts from other function groups which border on the illustrated function group.
 - The above section of the page of illustrations contains a total view of the machine. The place for the installation of the parts pictured here is marked by the grid.
 - The framed-in sections on the illustration pages show the individual parts comprising a group.
 - The key markings used on the illustrated pages (; 2 ; 3 etc.) are listed in the chapter "Explanation of key markings".
-
- Le numéro de série de la machine pour laquelle cette liste de pièces est valable est indiqué sur la première page.
 - Toutes les pièces sont représentées en fonction de leur groupement fonctionnel dans la machine.
 - Les pièces hâchurées indiquent les pièces limitrophes de groupes de fonctions différents.
 - La partie supérieure des pages de figures comprend une présentation globale de la machine. L'emplacement des pièces représentées est signalé par quadrillages.
 - Les parties encadrées sur les pages à illustrations représentent les pièces individuelles formant groupe.
 - Vous trouverez au chapitre „Explication des symboles“ une liste des symboles utilisés sur les pages de figures (; 2 ; 3 etc.)
-
- El número de serie de la máquina para la cual tiene validez esta lista de piezas va indicado en la página de título.
 - Todas las piezas están ilustradas tal como aparecen en la máquina para su funcionamiento.
 - Las piezas representadas con rayitas muestran piezas colindantes de otros grupos de funciones.
 - En la parte superior de las páginas ilustradas se puede ver una vista en conjunto de la máquina.
 - El lugar de montaje de la pieza representada va caracterizada mediante una superficie reticulada.
 - Los recuadros en las páginas ilustradas indican las piezas individuales de que se componen los grupos.
 - Los signos clave (; 2 ; 3 etc.) empleados en las páginas con ilustraciones van listados en el capítulo „Explicaciones de los signos clave“

- 3** **Geklebt**
Part cemented
Pièce collée
Pieza pegada
- 3/1** **Gesichert mit Loctite**
Secured with Loctite
Bloqué par Loctite
Asegurado con loctite
- 3/4** **Selbstklebend**
Self-adhesive
Auto-adhesif
Autoadesivo
- 6** **Nadeldicke und Spitzenform bei Bestellung angeben.**
Needle size and style of point to be stated on order.
Préciser la grosseur de l'aiguille et la forme de la pointe à la commande.
Grosor de aguja y forma de la punta, indíquese en los pedidos
- 27/2** **Eingeklammerte Zahl = Dicke in mm.**
Number in brackets = thickness in mm.
Chiffre entre parenthèses = épaisseur en mm.
Cifra entre paréntesis = espesor en mm.
- 27/5** **Eingeklammerte Zahl = Länge in mm.**
Number in brackets = length in mm.
Chiffre entre parenthèses = longueur en mm.
Cifra entre paréntesis = largura en mm.
- 27/19** **Eingeklammerte Zahl = Stichlochbreite in mm.**
Number in brackets = needle hole width in mm..
Chiffre entre parenthèses = largeur du trou d'aiguille en mm.
Cifra entre paréntesis = anchura del agujero passante para la aguja en mm.
- 27/20** **Eingeklammerte Zahl = Stichlochdurchmesser in mm.**
Number in brackets = needle hole diameter in mm..
Chiffre entre parenthèses = diamètre du trou d'aiguille en mm.
Cifra entre paréntesis = diámetro del agujero passante para la aguja en mm.
- 28** **Sonderausführung**
Special version
Version spéciale
Tipo especial
- 32** **Beim Einbau dieses Teiles wird für die Paßgenauigkeit zum Anschlußteil keine Garantie übernommen; zweckmäßig vollständiges Aggregat bestellen.**
No guarantee is assumed that this part will fit the mating part; it is best to order a complete assembly.
Aucune garantie ne pourra être assurée quant à la précision d'ajustage de cette pièce avec lapièce correspondante; il est indiqué de commander un mécanisme complet.
Al montar esta pieza no se asume garantía alguna en cuanto a la tolerancia y precisión de ajuste respecto a la pieza correspondiente; por esta razón, se recomienda pedir el grupo completo.

-
- 40/2** **Tränken mit 28-011 201-44; Bestellnummer siehe Seite 87.**
Soak with 28-011 201-44; for part number see page 87.
Imbiber d'huile 28-011 201-44; n° de commande, voir page 87.
Empape con aceite 28-011 201-44; para el número de pedido véase la página 87.
- 40/3** **Fetten mit 28-011 202-47; Bestellnummer siehe Seite 87.**
Grease with 28-011 202-47; for part number see page 87.
Graisser avec de la graisse 28-011 202-47; n° de commande, voir page 87.
Engrase con grasa 28-011 202-47; para el número de pedido véase la página 87.
- 40/4** **Fetten mit 28-011 202-43; Bestellnummer siehe Seite 87.**
Grease with 28-011 202-43; for part number see page 87.
Graisser avec de la graisse 28-011 202-43; n° de commande, voir page 87.
Engrase con grasa 28-011 202-43; para el número de pedido véase la página 87.
- 40/5** **Ölen mit 28-011 201-44; Bestellnummer siehe Seite 87.**
Oil with 28-011 201-44; for part number see page 87.
Huiler avec de la graisse 28-011 201-44; n° de commande, voir page 87.
Lubrifique con grasa 28-011 201-44; para el número de pedido véase la página 87.
- 40/13** **Fetten mit 28-011 202-05; Bestellnummer siehe Seite 87.**
Grease with 28-011 202-05; for part number see page 87.
Graisser avec de la graisse 28-011 202-05; n° de commande, voir page 87.
Engrase con grasa 28-011 202-05; para el número de pedido véase la página 87.
- 40/22** **Füllen mit 28-011 202-10; Bestellnummer siehe Seite 87.**
Top up with 28-011 202-10; for part number see page 87.
Remplir de 28-011 202-10; n° de commande, voir page 87.
Rellene con 28-011 202-10; para el número de pedido véase la página 87.
- 81/1** **Stückzahl je nach Bedarf.**
Quantity as required.
Nombre en fonction besoin.
Cantidad según sea necesario.
- 81/3** **Verwendung je nach Bedarf.**
To be used required.
Utilisation en fonction des besoins.
Utilización, según sea necesario
- 96** **Länge angeben.**
State length.
Préciser longueur.
Indíquese la largura.

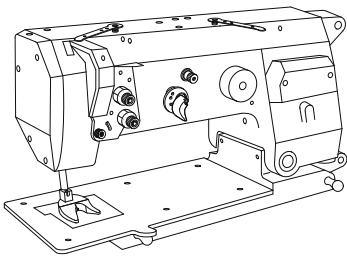

Gehäuseteile
 Housing sections
 Parties du corps
 Piezas del cárter

PFAFF 3588-05/020

3.01

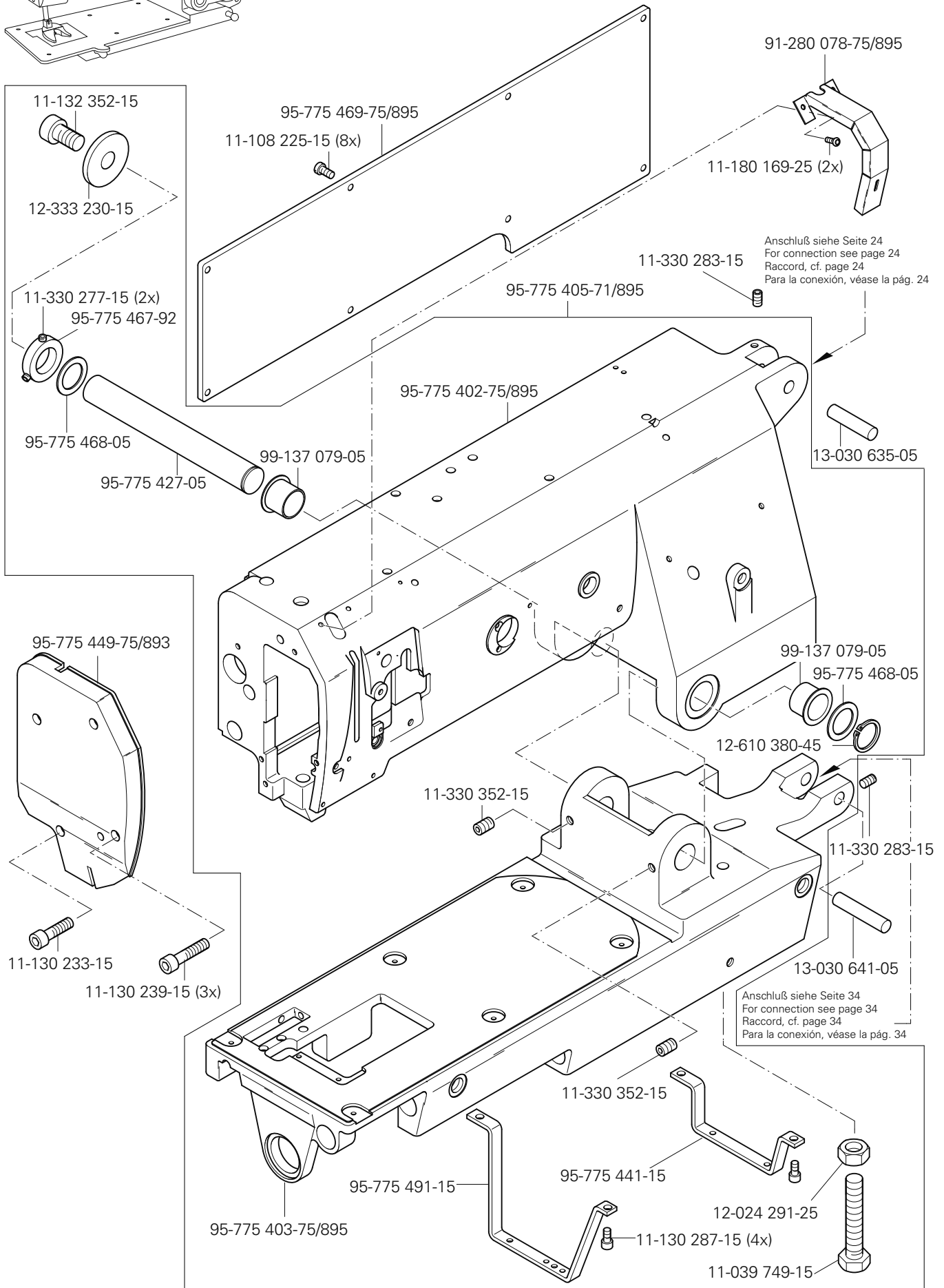

3.02

Kopfteil
Needle head parts
Pièces de tête
Piezas de la cabeza

PFAFF 3588-05/020

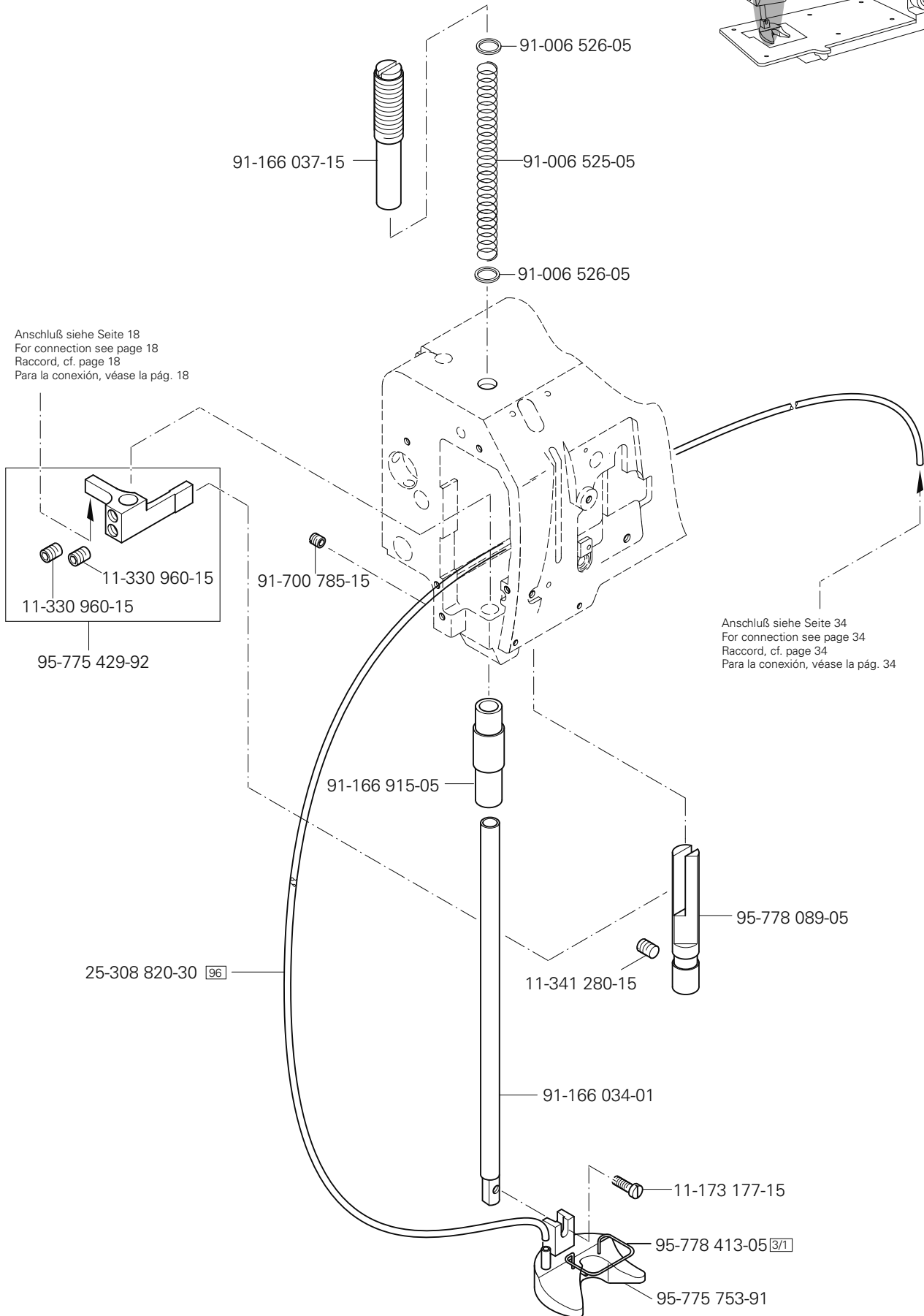
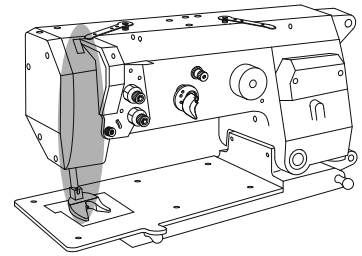

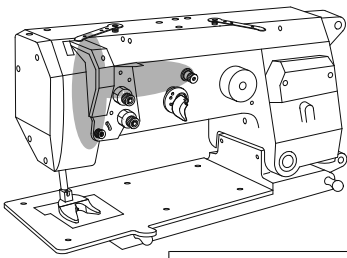

Kopfteile
Needle head parts
Pièces de tête
Piezas de la cabeza

PFAFF 3588-05/020

3.02

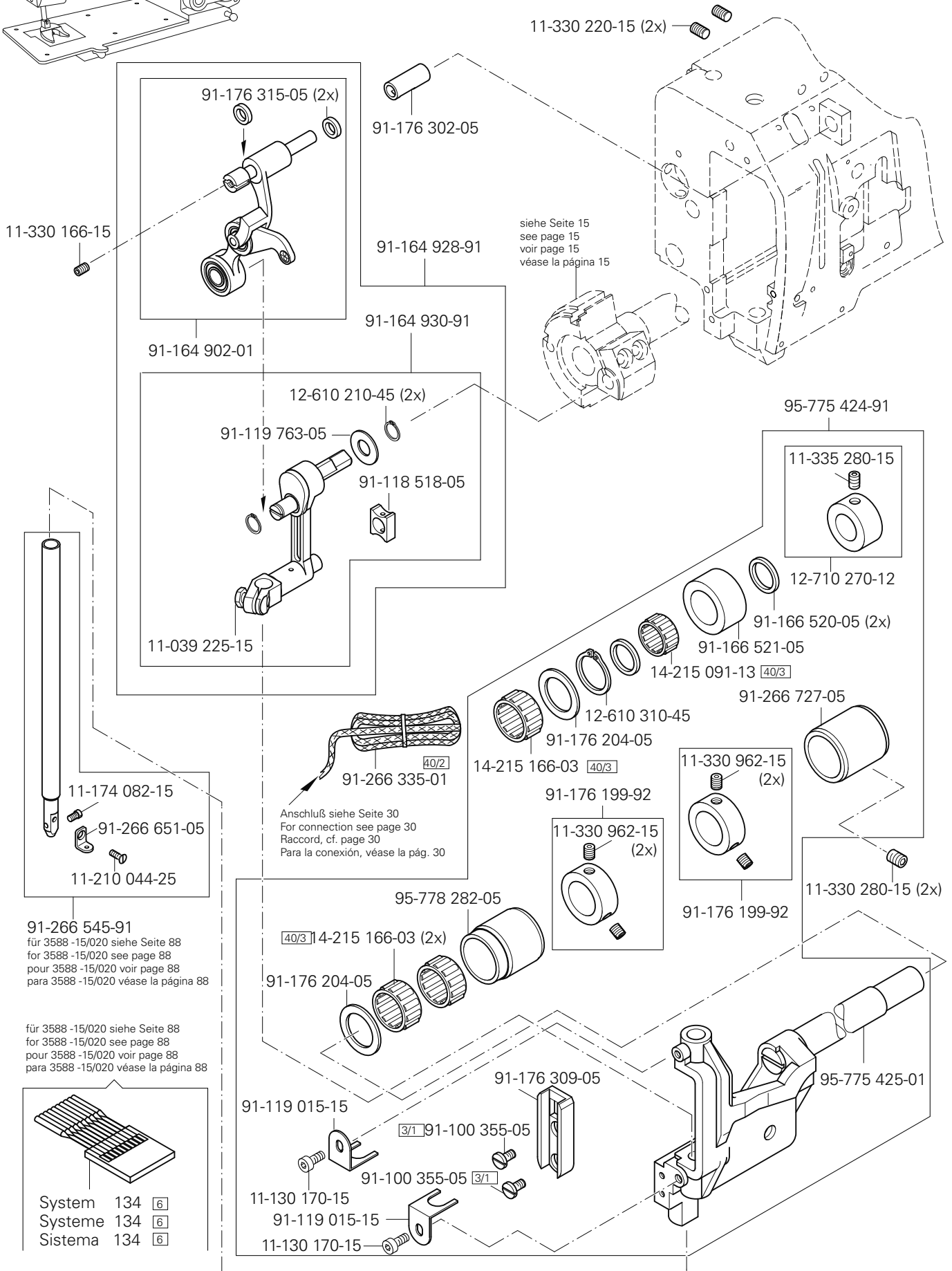

3.02

Kopfteile Needle head parts Pièces de tête Piezas de la cabeza

PFAFF 3588-05/020

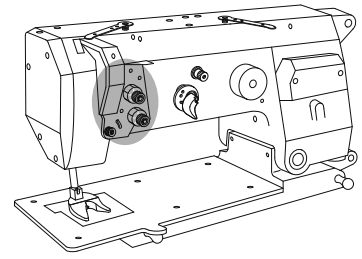

Anschluß siehe Seite 33
For connection see page 33
Raccord, cf. page 33
Para la conexión, véase la pág. 33

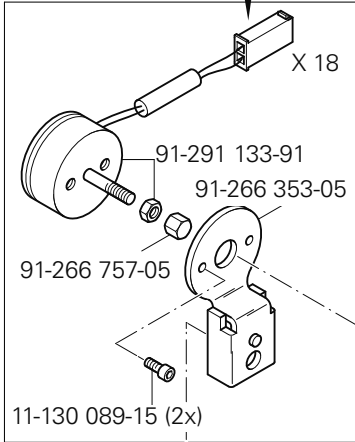

91-266 456-91

25-308 820-30 96

Anschluß siehe Seite 34
For connection see page 34
Raccord, cf. page 34
Para la conexión, véase la pág. 34

11-108 120-25 (2x)
99-135 066-91
91-166 889-05

91-166 889-05
99-135 490-91

91-266 037-05

Anschluß siehe Seite 19
For connection see page 19
Raccord, cf. page 19
Para la conexión, véase la pág. 19

11-130 281-15

25-308 820-30 96

95-778 374-91

91-176 332-25

11-132 169-15

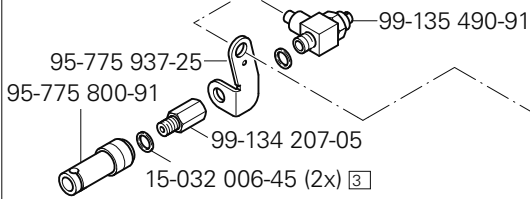

95-778 175-91

91-118 430-25

91-176 431-05

11-180 223-25

11-180 175-25 (2x)

95-775 929-71/698

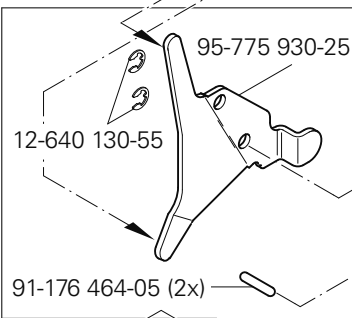

91-266 414-05 (2x)

91-176 464-05 (2x)

11-180 223-25

11-174 176-15

91-176 337-15

91-176 324-25

12-315 090-25

91-010 937-05

91-266 411-25

11-172 127-25

13-033 109-05

13-033 091-05

11-180 169-25

91-176 378-05

91-176 373-21

91-701 522-25

91-056 193-25

91-056 193-25

95-775 939-91

11-330 169-15

12-005 154-25

12-005 154-25

91-002 065-05 (4x)

91-002 262-25 (2x)

91-010 183-05 (2x)

91-105 447-25 (2x)

91-168 194-71/698 (2x)

91-056 193-25

91-056 760-05

91-056 192-25

96 siehe Kapitel 2 Erläuterung der Schlüsselzeichen
see chapter 2 Explanation of key markings
voir le chap. 2 Explication des symboles
véase el Cap. 2 Explicaciones de los signos clave

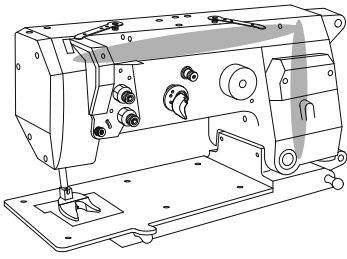

Armteile
 Arm parts
 Pièces de bras
 Piezas del brazo PFAFF 3588-05/020

3.03

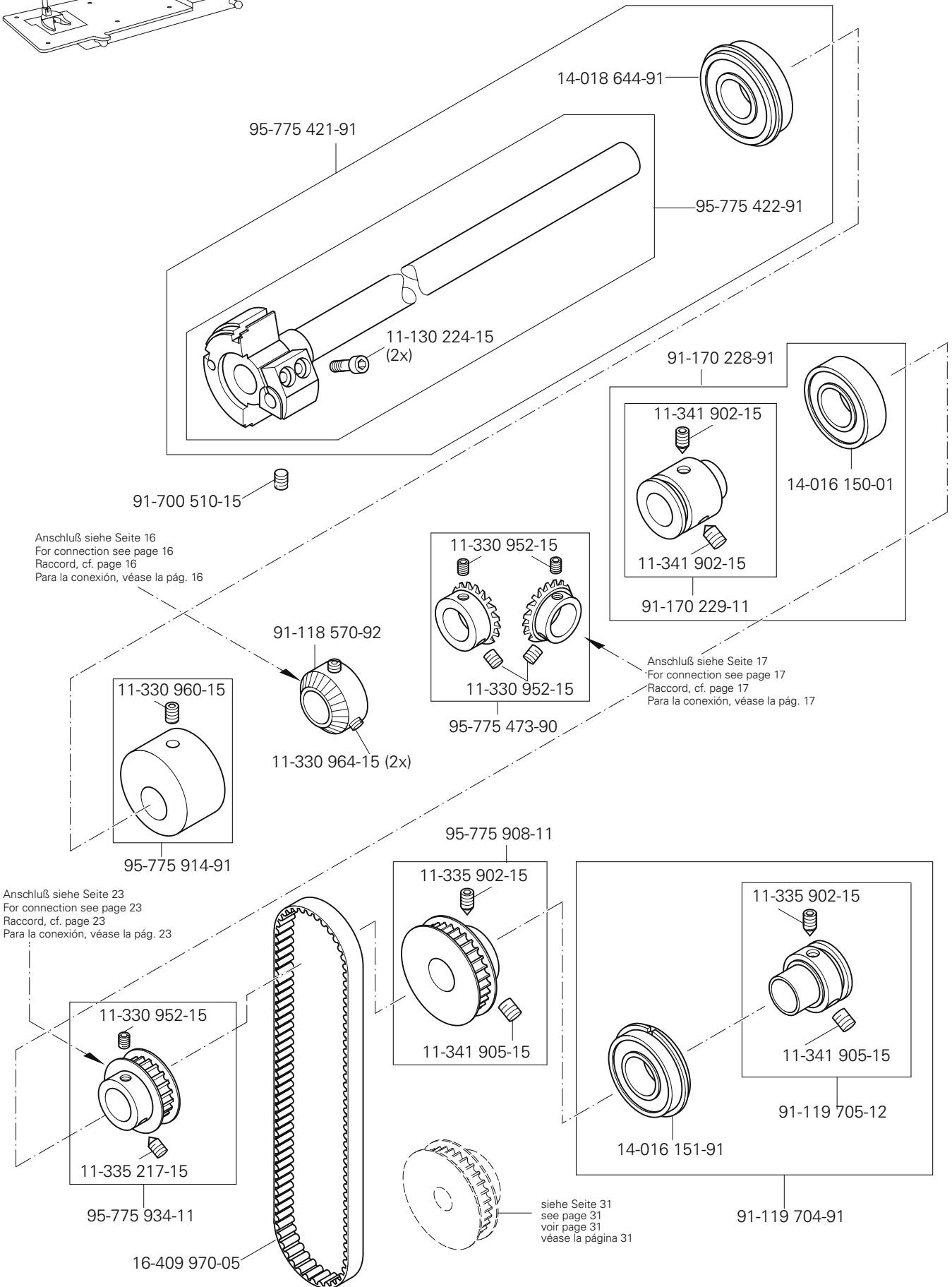

3.03

Armteile
 Arm parts
 Pièces de bras
 Piezas del brazo

PFAFF 3588-05/020

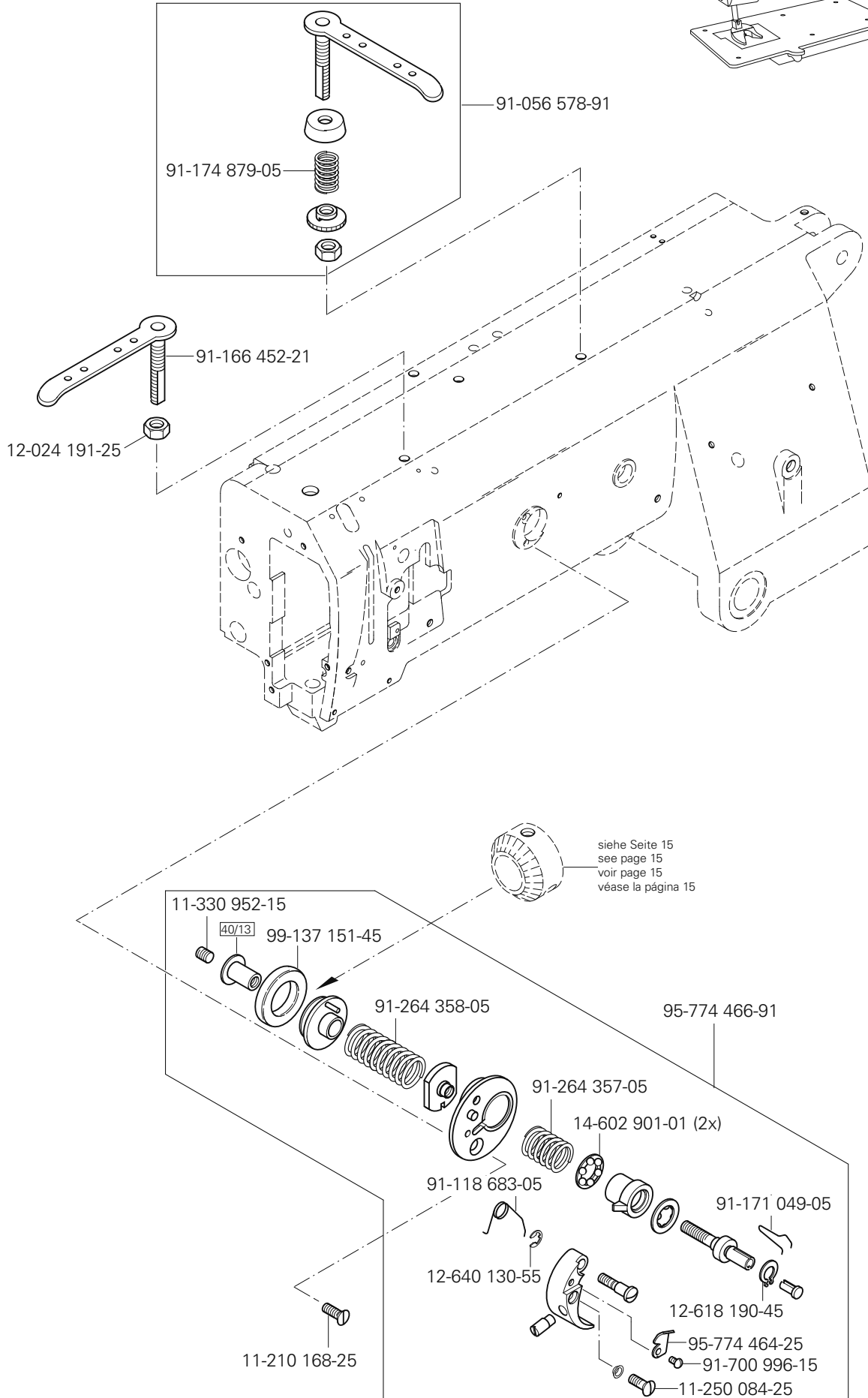
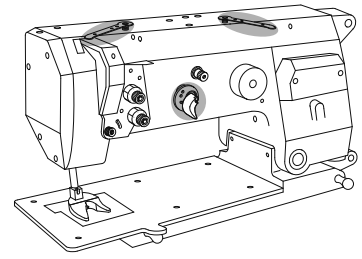

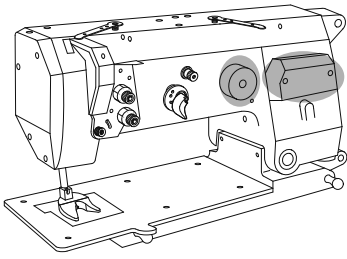

Armteile
 Arm parts
 Pièces de bras
 Piezas del brazo PFAFF 3588-05/020

3.03

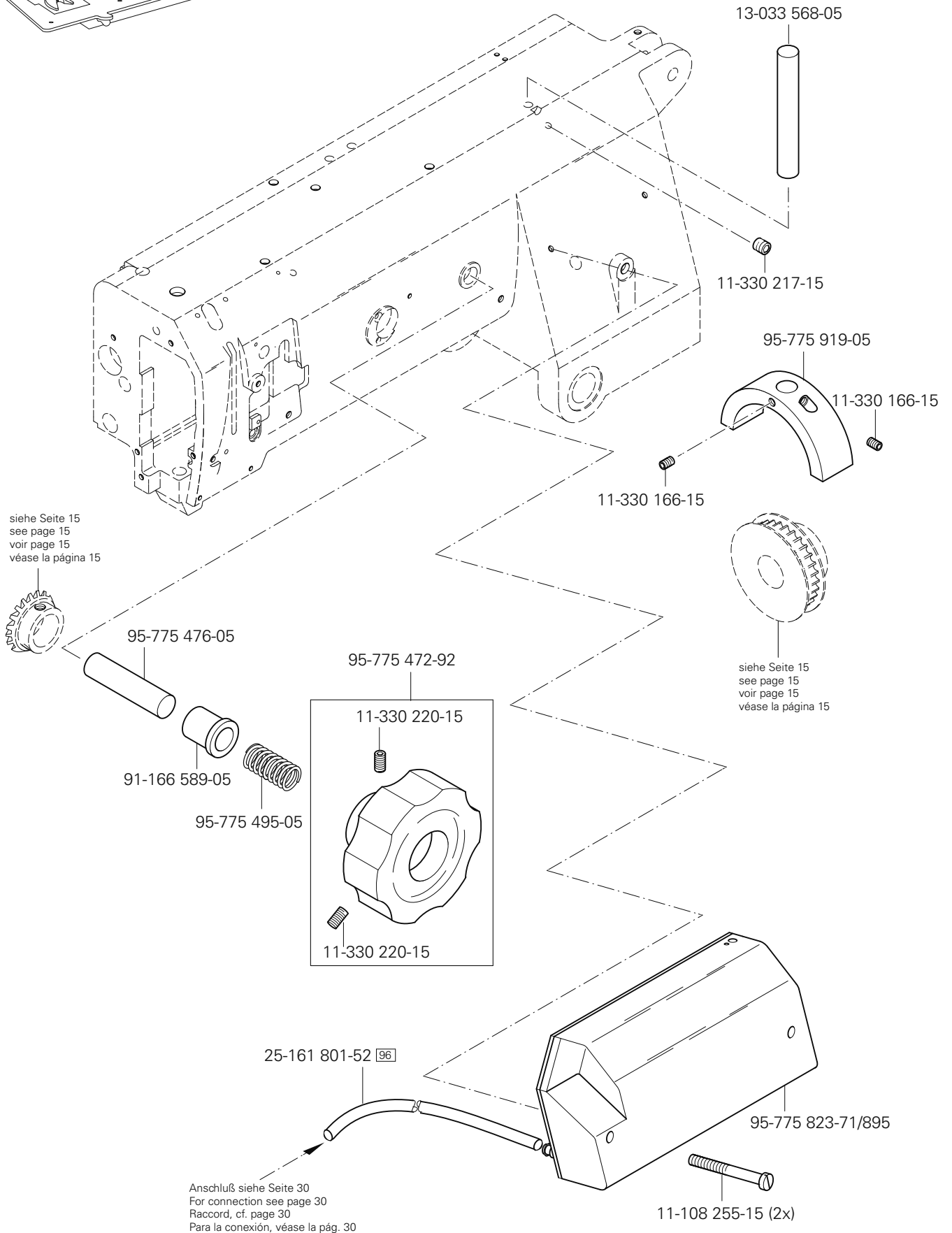

3.03

Armteile
 Arm parts
 Pièces de bras
 Piezas del brazo

PFAFF 3588-05/020

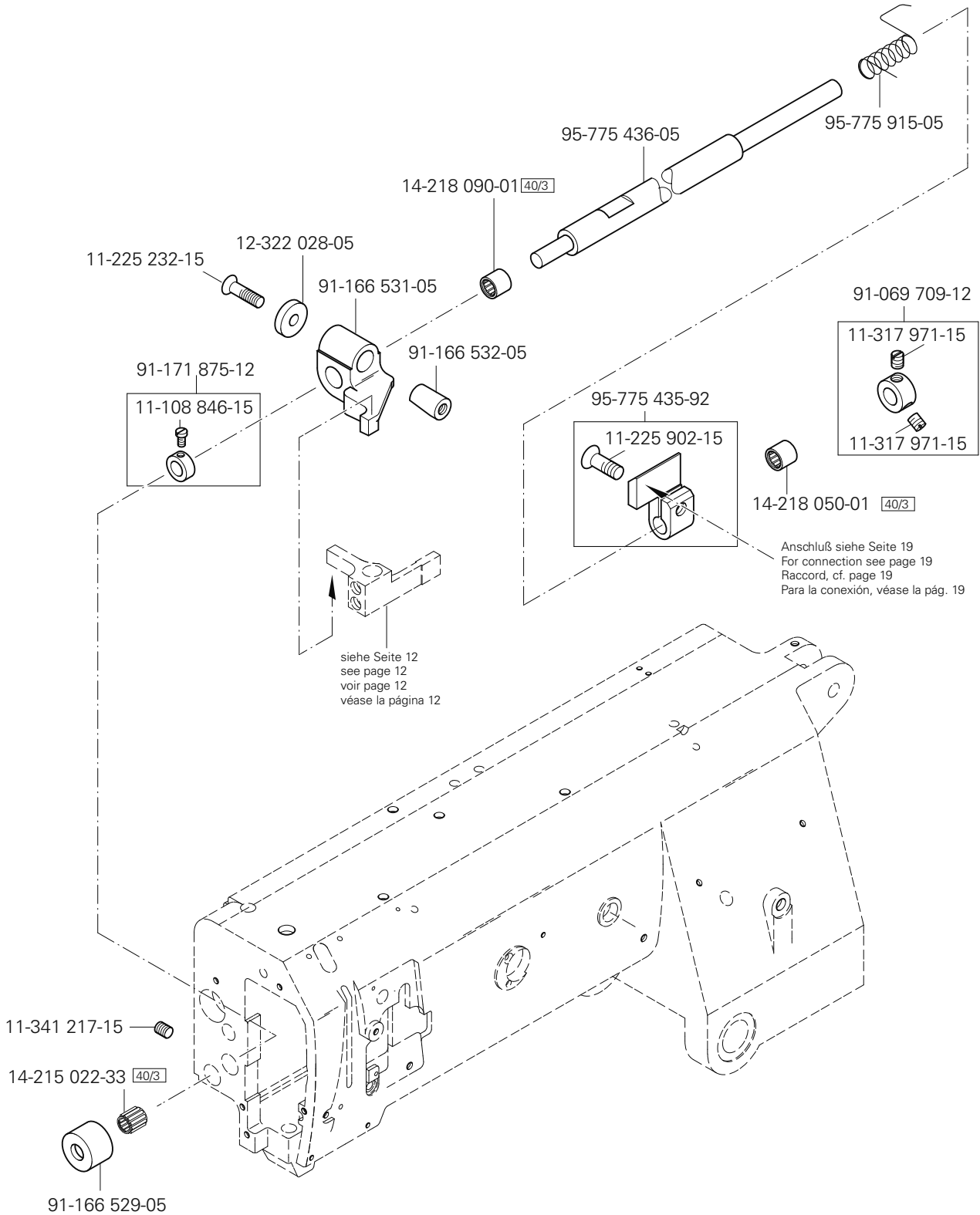
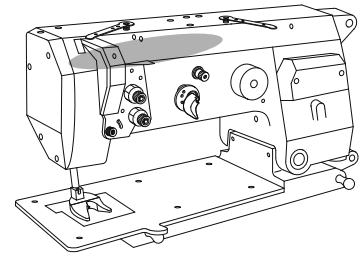

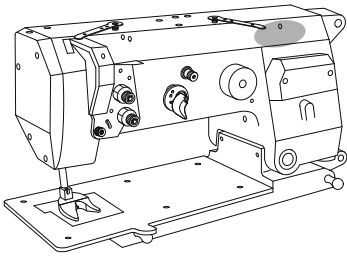

Armteile
 Arm parts
 Pièces de bras
 Piezas del brazo PFAFF 3588-05/020

3.03

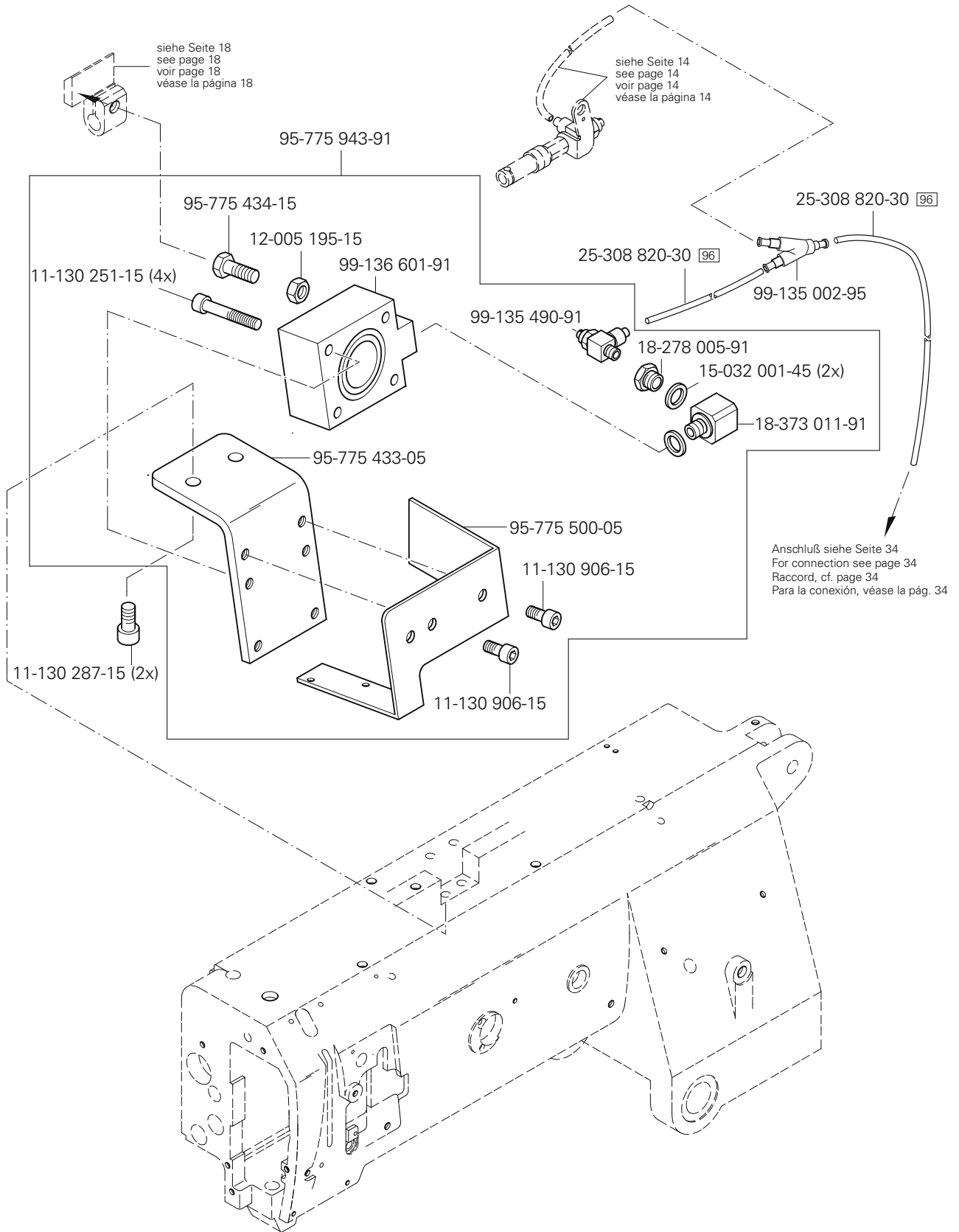

3.03

Armteile
 Arm parts
 Pièces de bras
 Piezas del brazo

PFAFF 3588-05/020

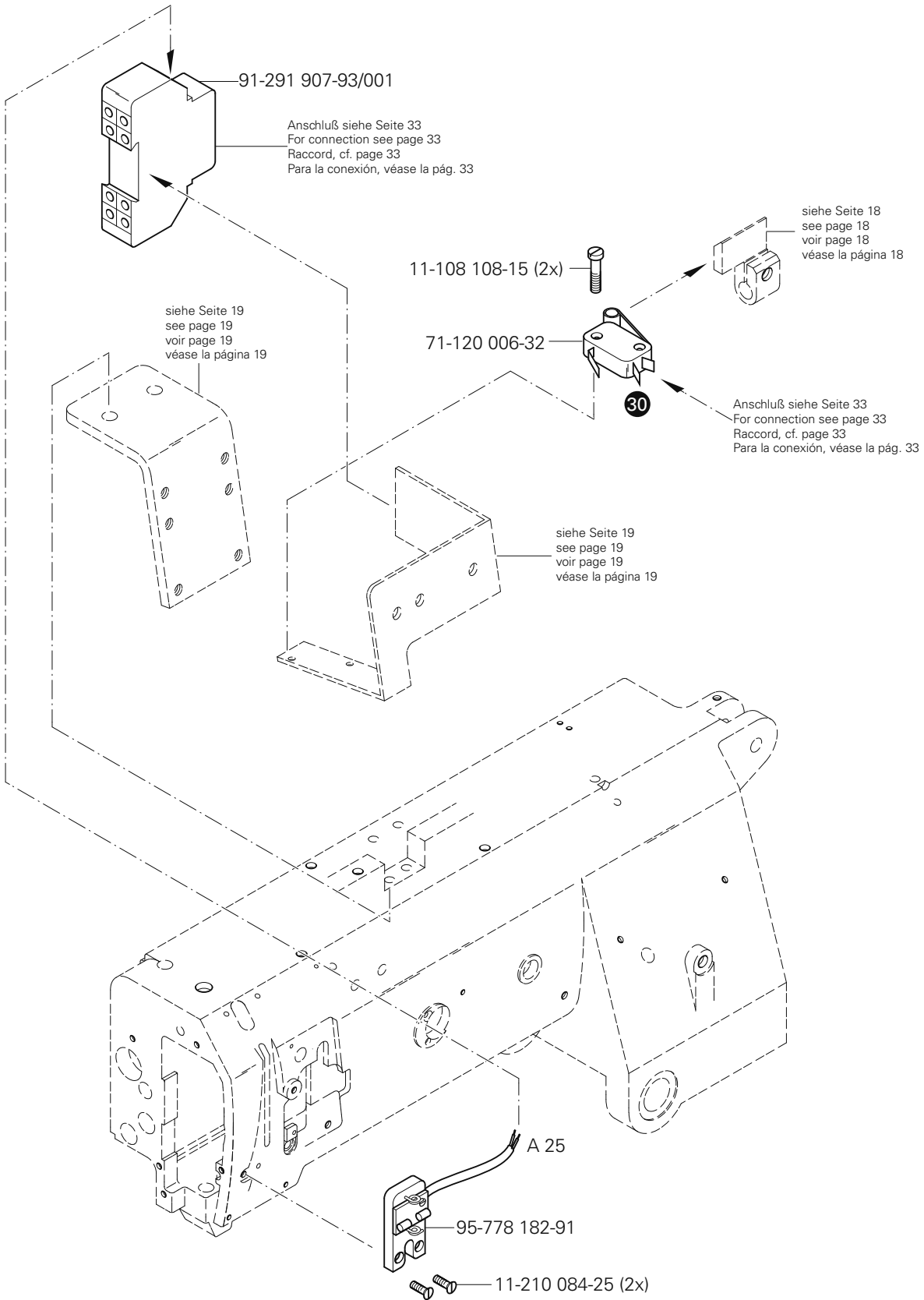
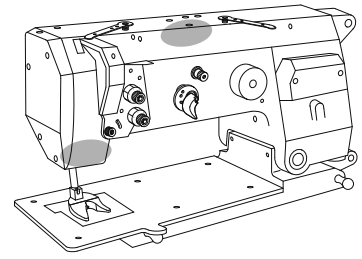

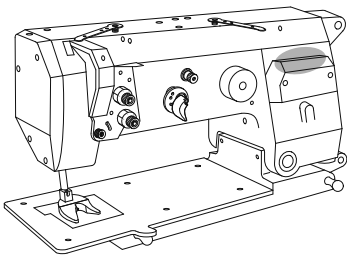

Armteile
 Arm parts
 Pièces de bras
 Piezas del brazo PFAFF 3588-05/020

3.03

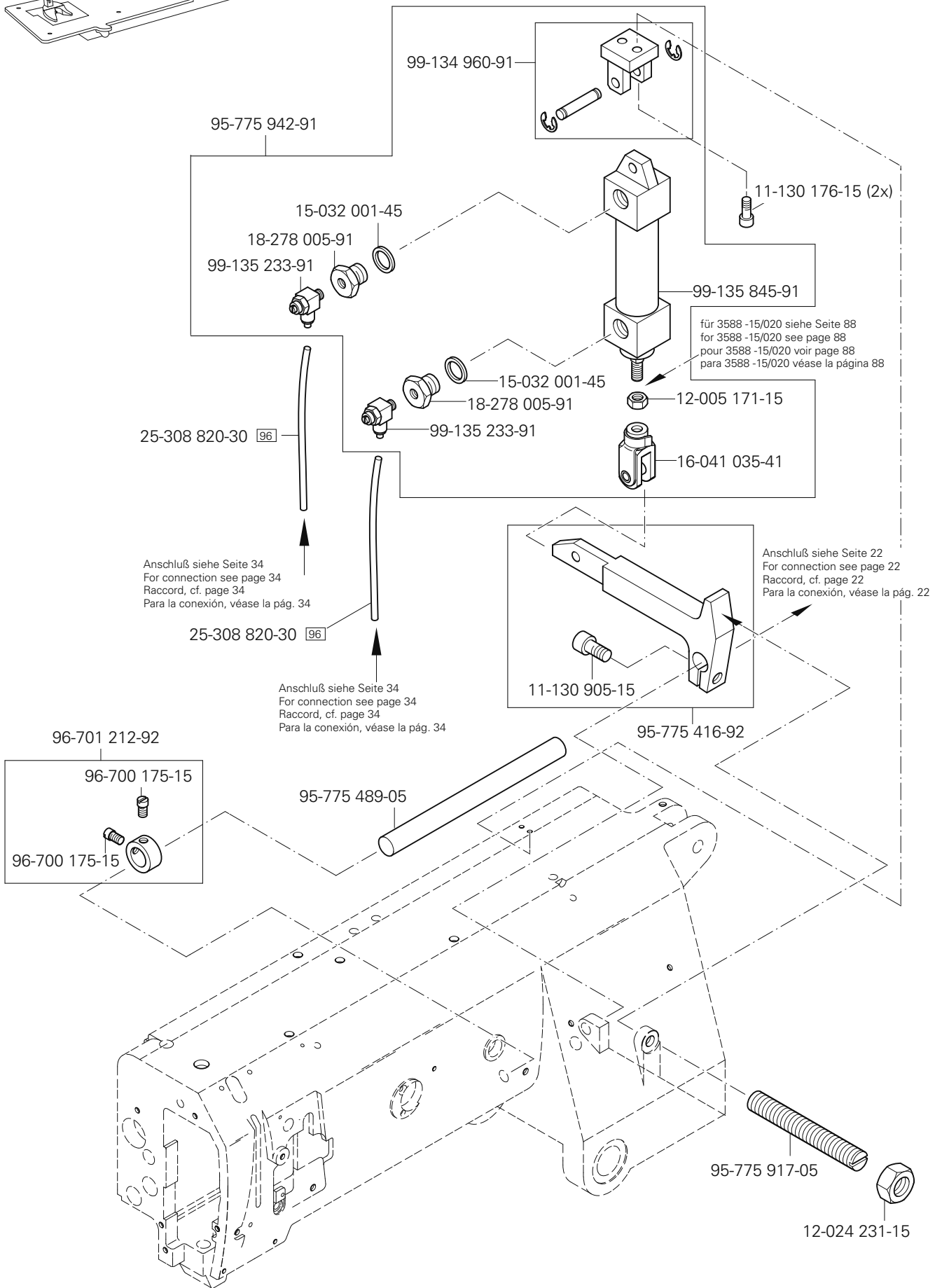

3.03

Armteile
 Arm parts
 Pièces de bras
 Piezas del brazo

PFAFF 3588-05/020

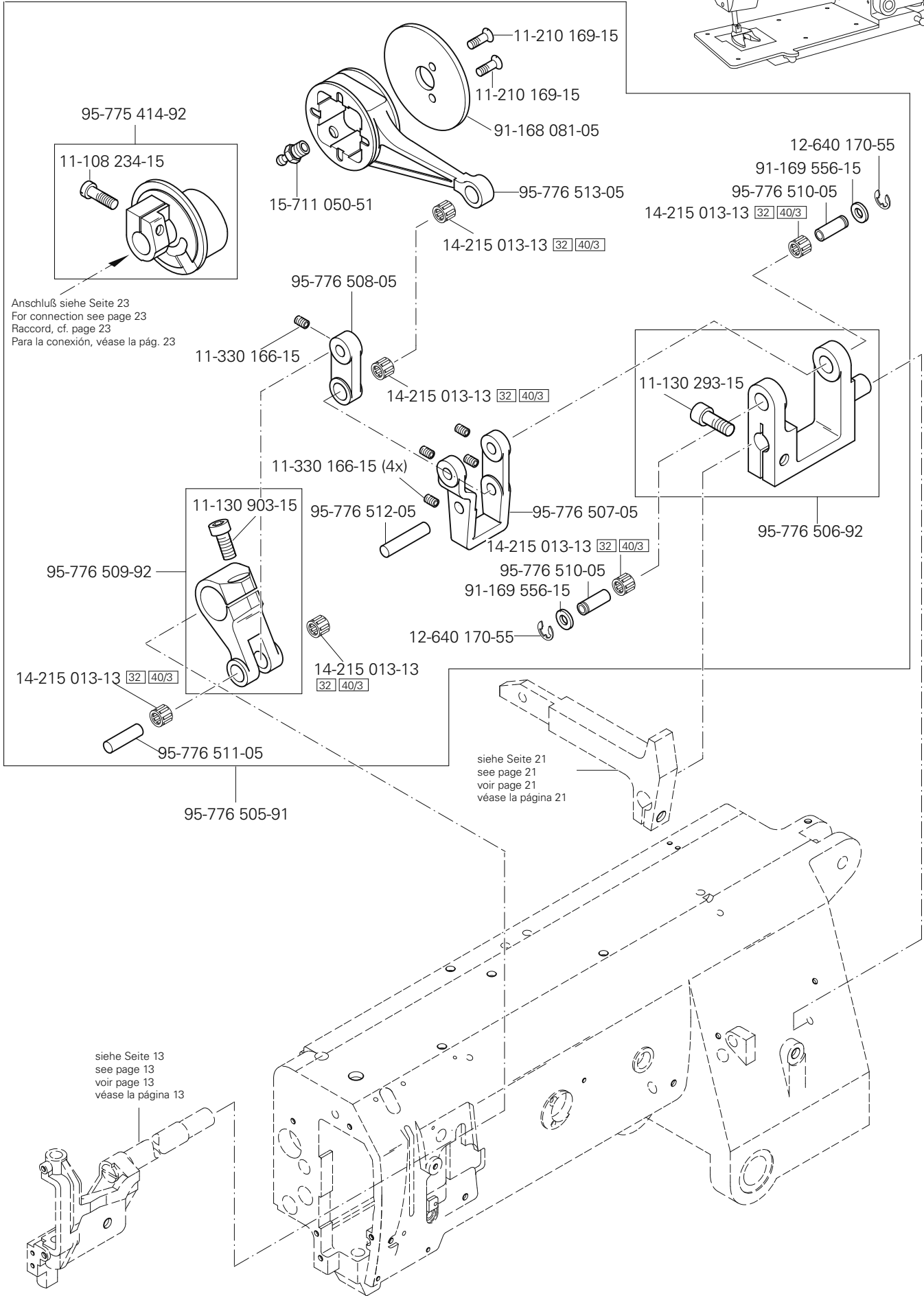
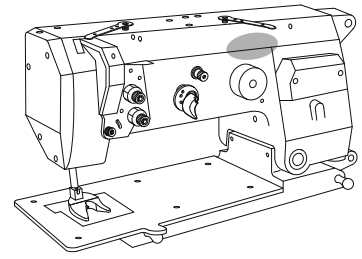

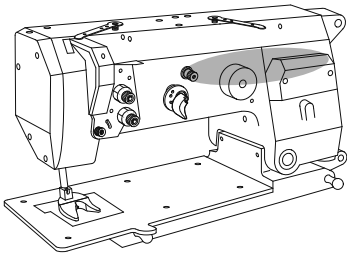

Armteile
 Arm parts
 Pièces de bras
 Piezas del brazo PFAFF 3588-05/020

3.03

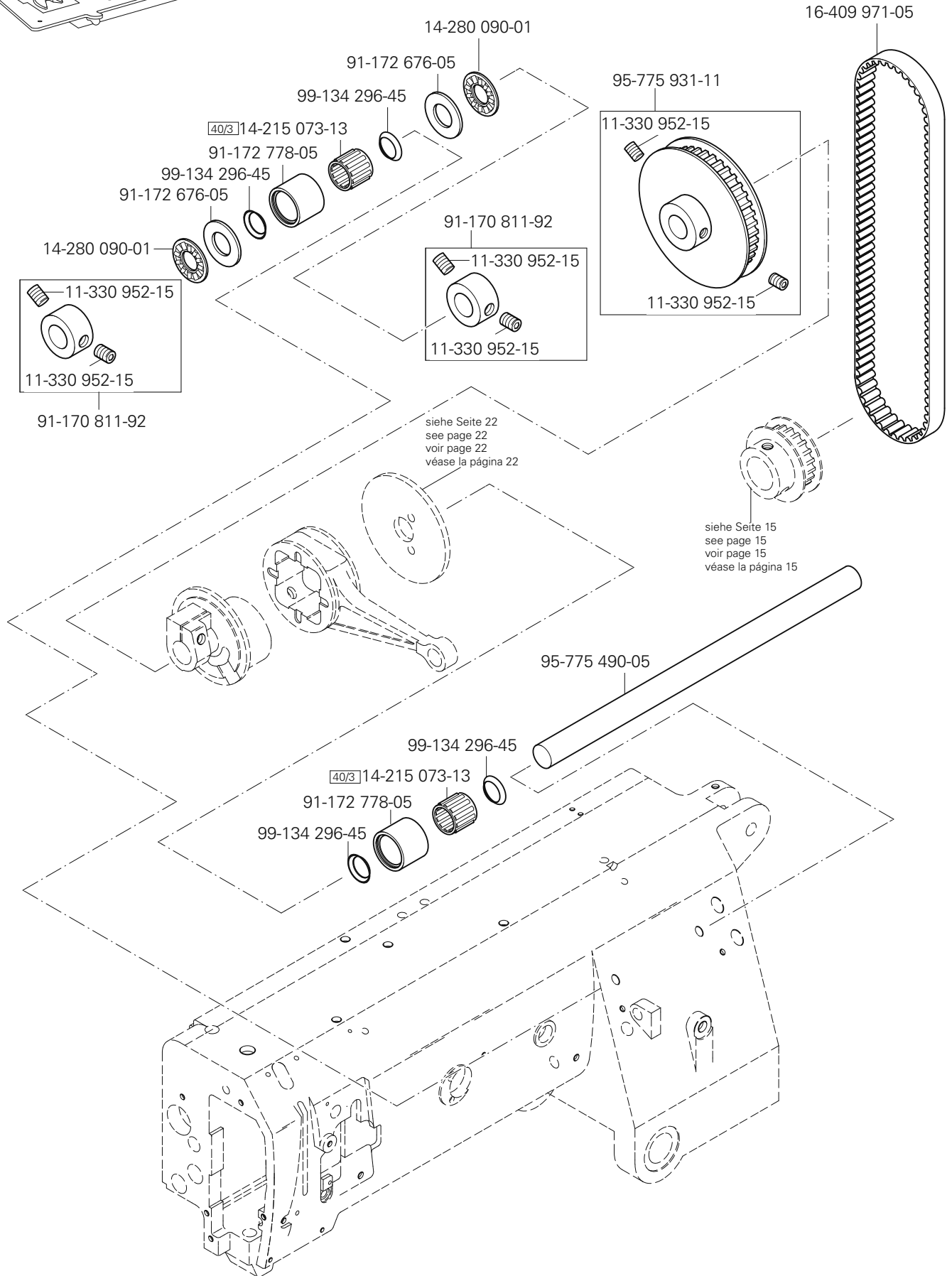

3.03

Armteile
 Arm parts
 Pièces de bras
 Piezas del brazo

PFAFF 3588-05/020

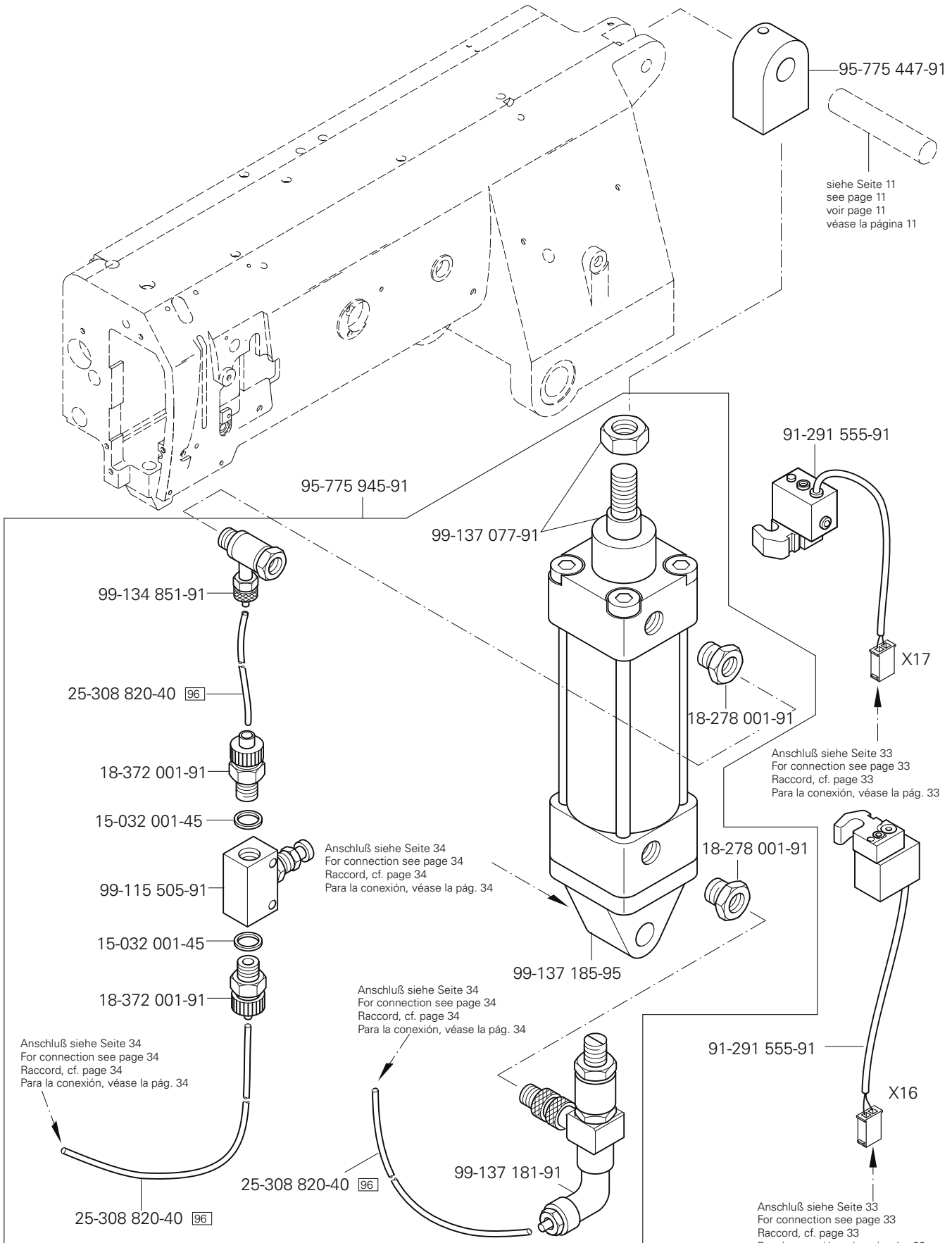
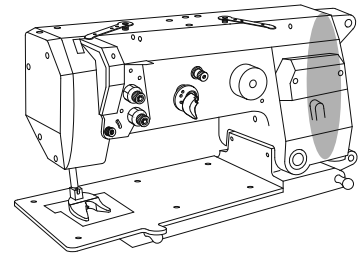

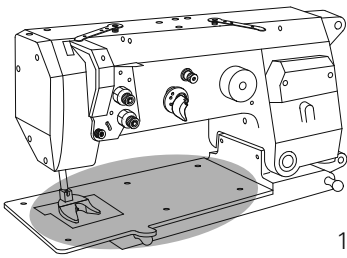

Grundplattenteile
 Bedplate parts
 Pièces du plateau fondamental
 Piezas del carter

PFAFF 3588-05/020

3.04

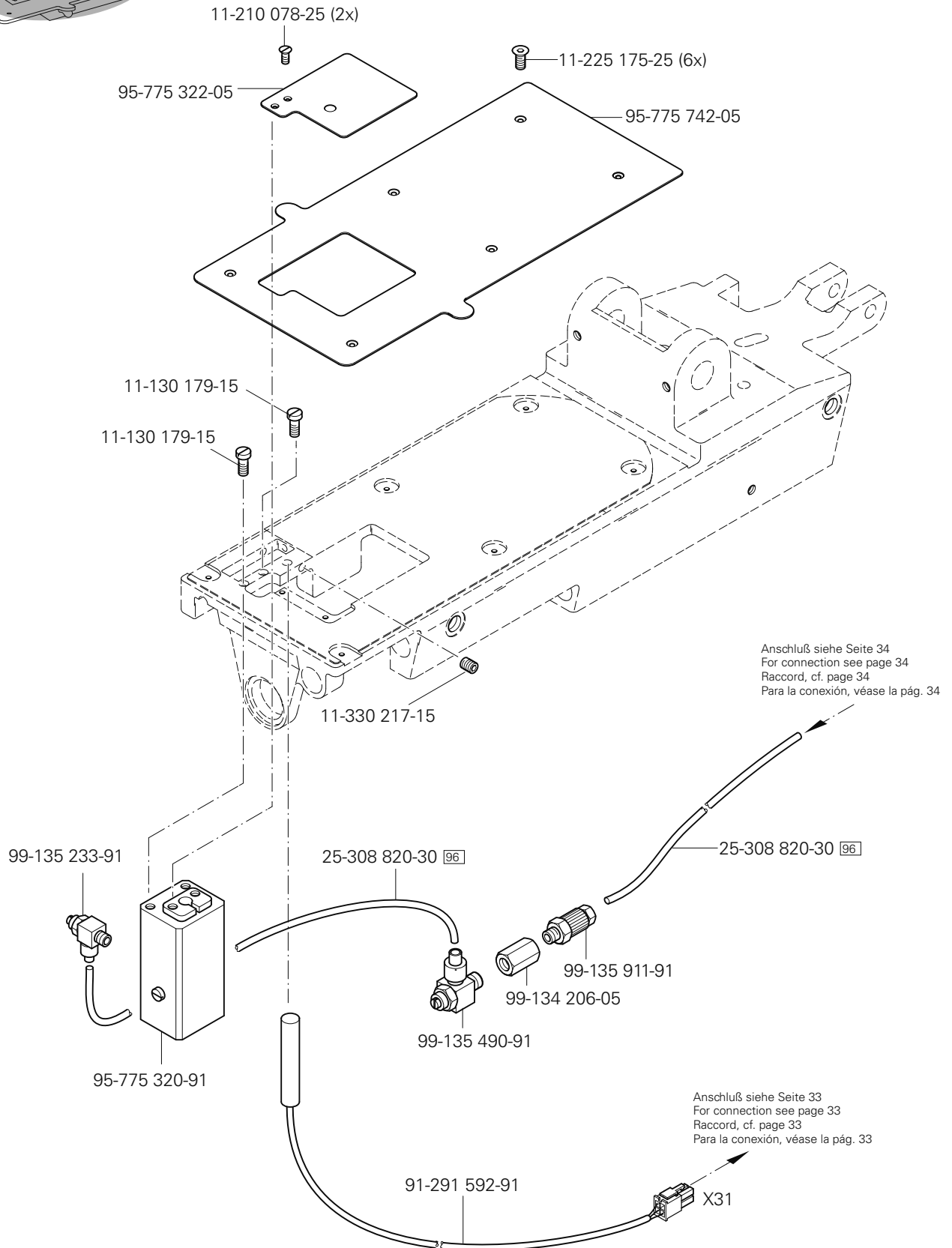

3.04

Grundplattenteile
Bedplate parts
Pièces du plateau fondamental
Piezas del carter

PFAFF 3588-05/020

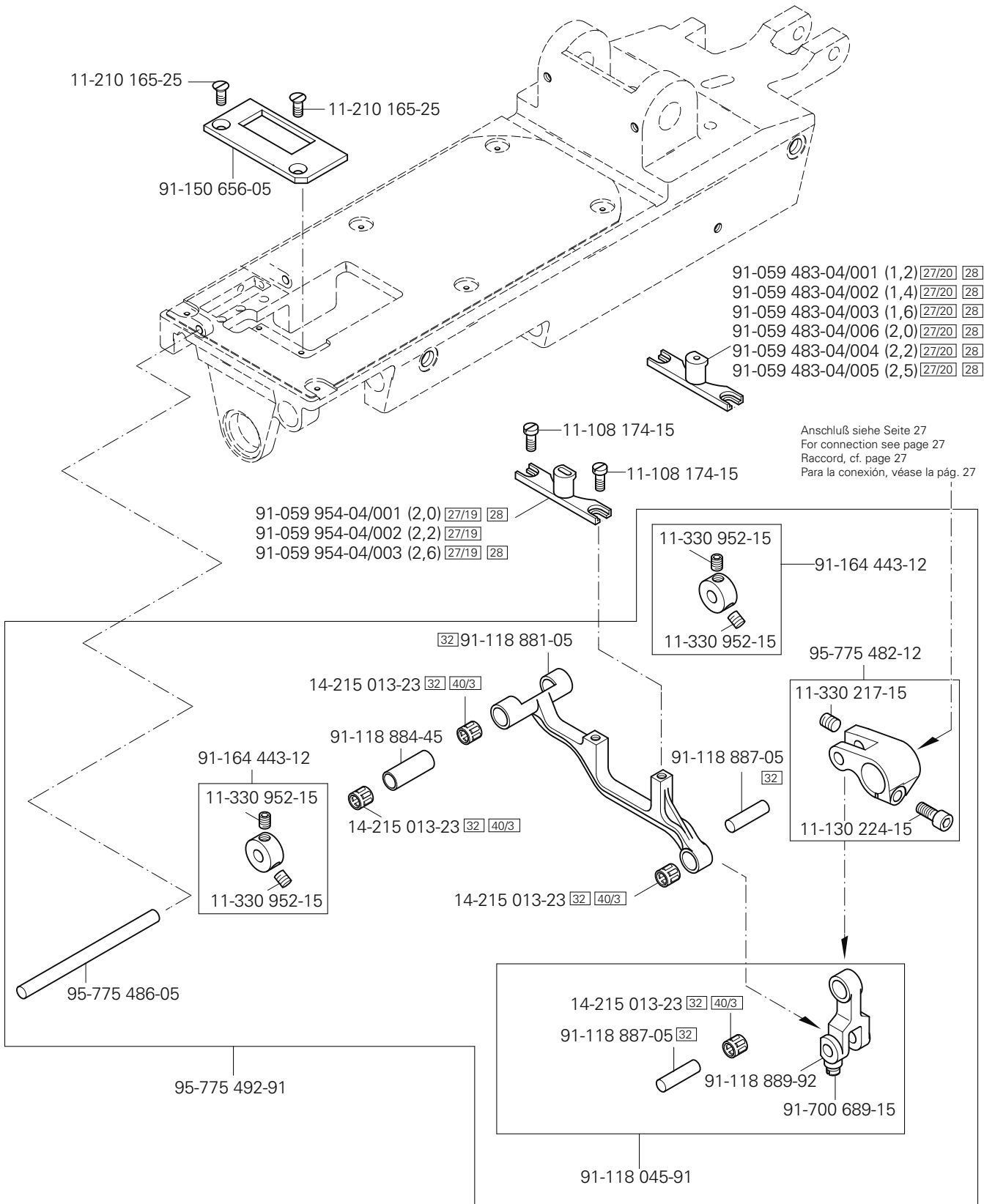
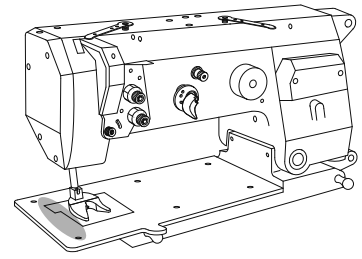

3.04

Grundplattenteile Bedplate parts Pièces du plateau fondamental Piezas del carter

PFAFF 3588-05/020

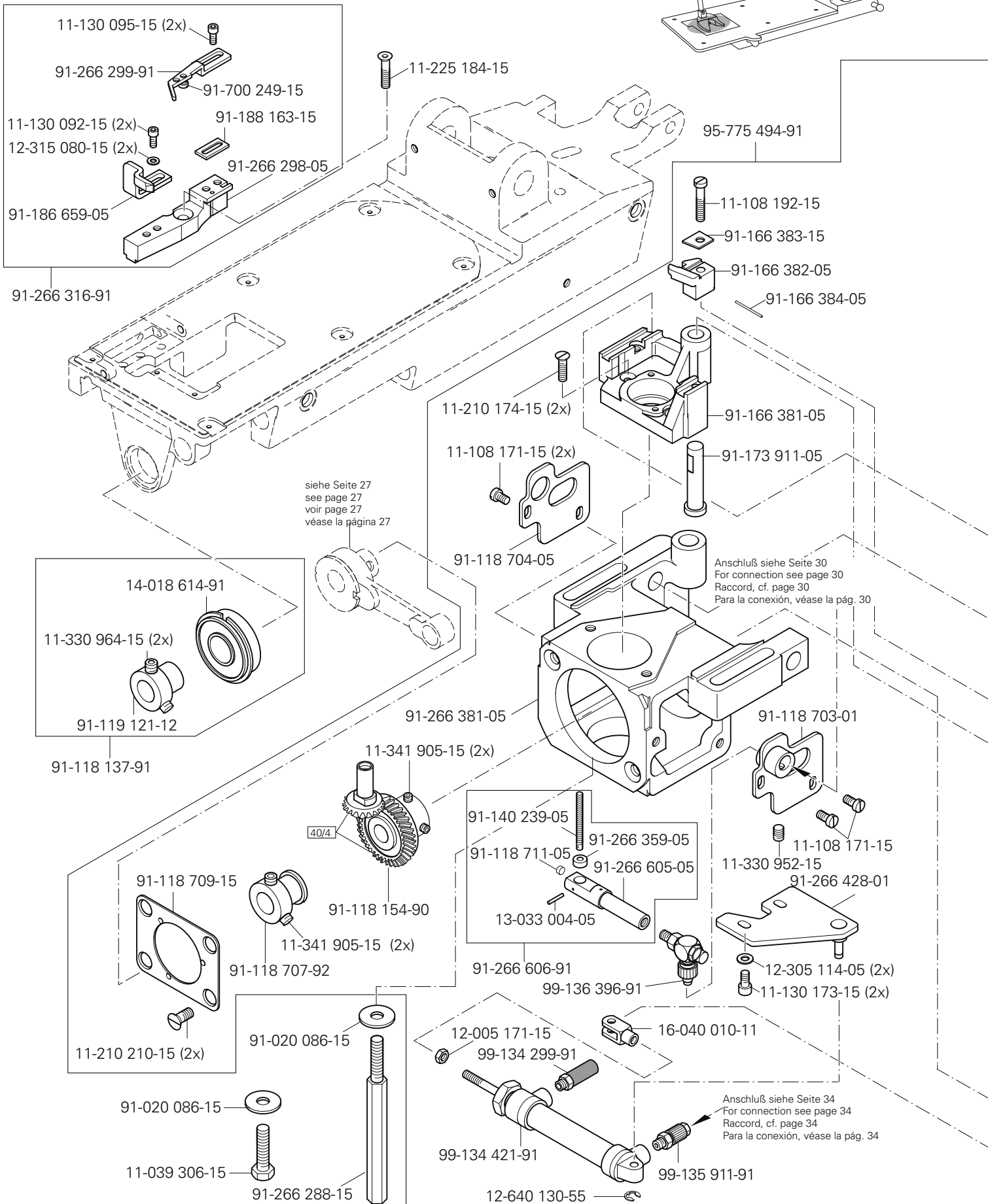
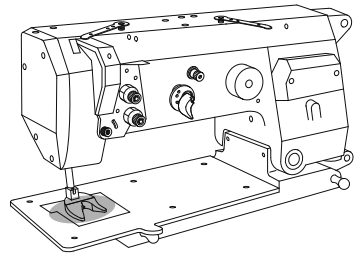

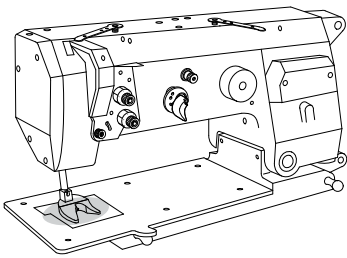

Grundplattenteile
Bedplate parts
Pièces du plateau fondamental
Piezas del carter

PFAFF 3588-05/020

3.04

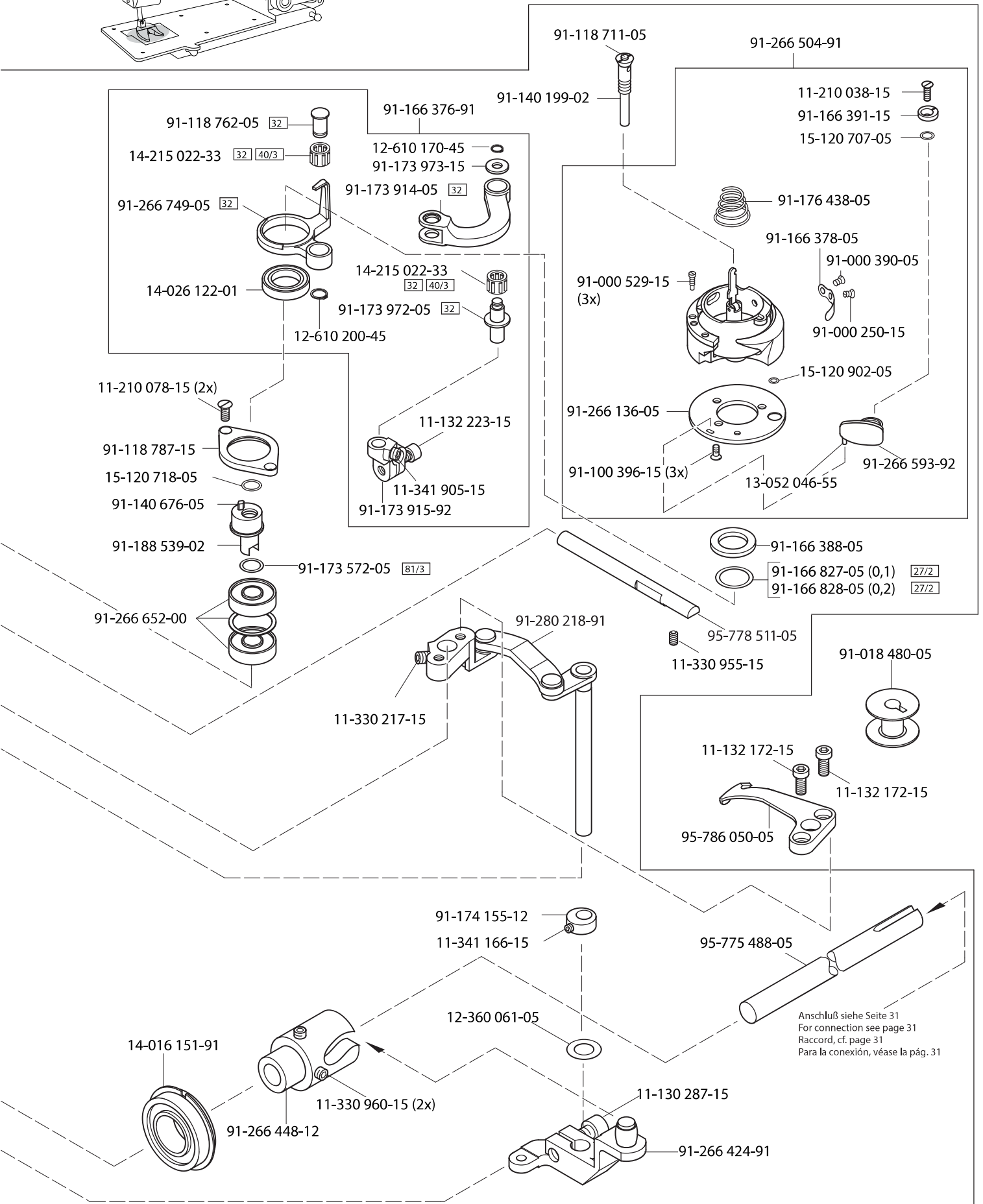

3.04

Grundplattenteile Bedplate parts Pièces du plateau fondamental Piezas del carter

PFAFF 3588-05/020

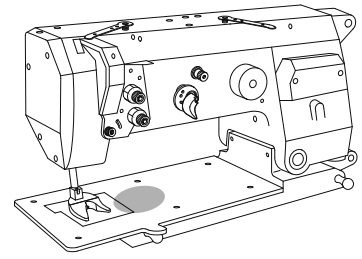

siehe Seite 17
see page 17
voir page 17
véase la página 17

siehe Seite 13
see page 13
voir page 13
véase la página 13

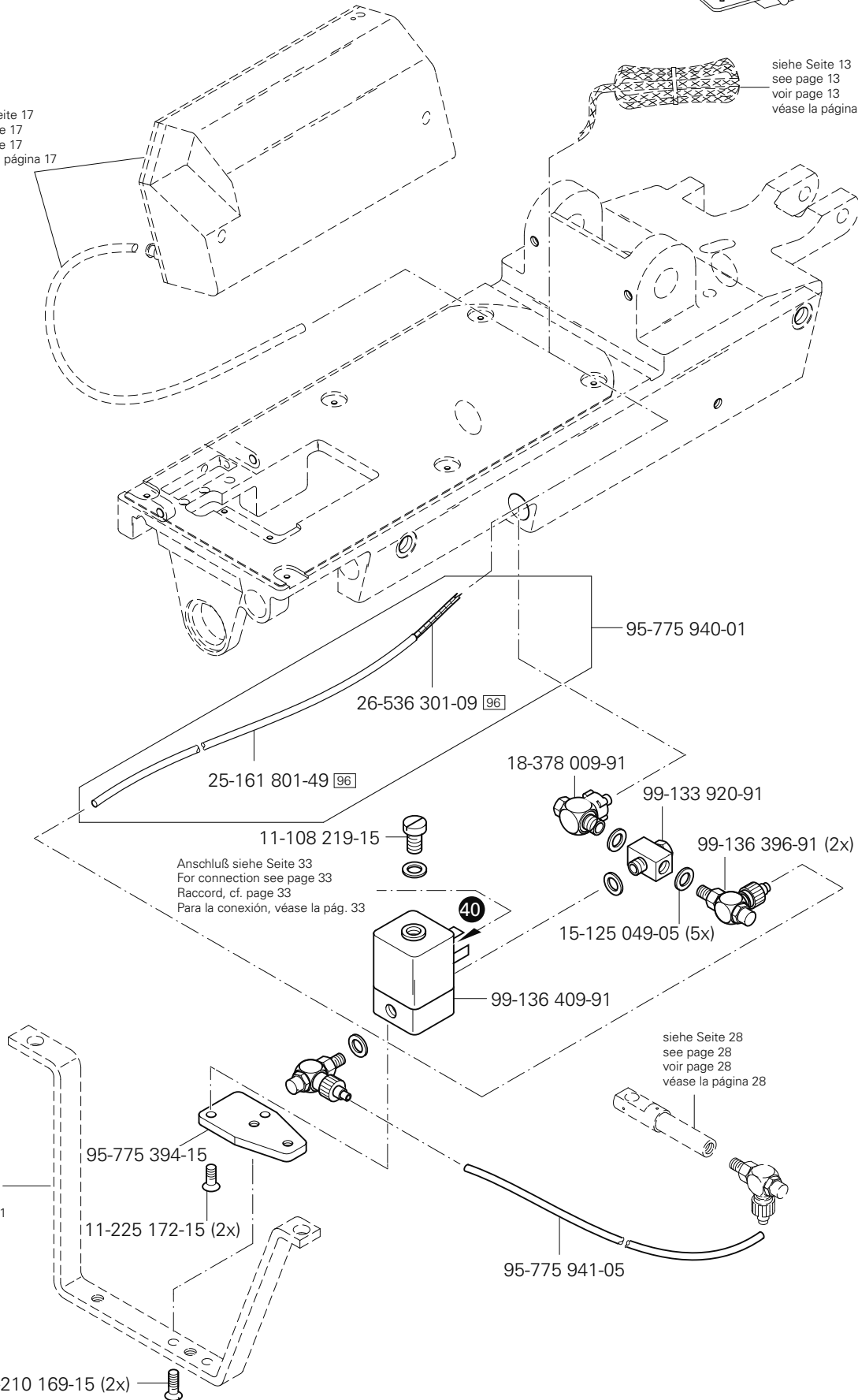

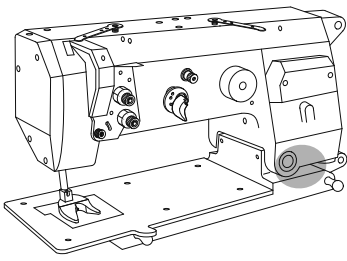

Grundplattenteile
 Bedplate parts
 Pièces du plateau fondamental
 Piezas del carter

PFAFF 3588-05/020

3.04

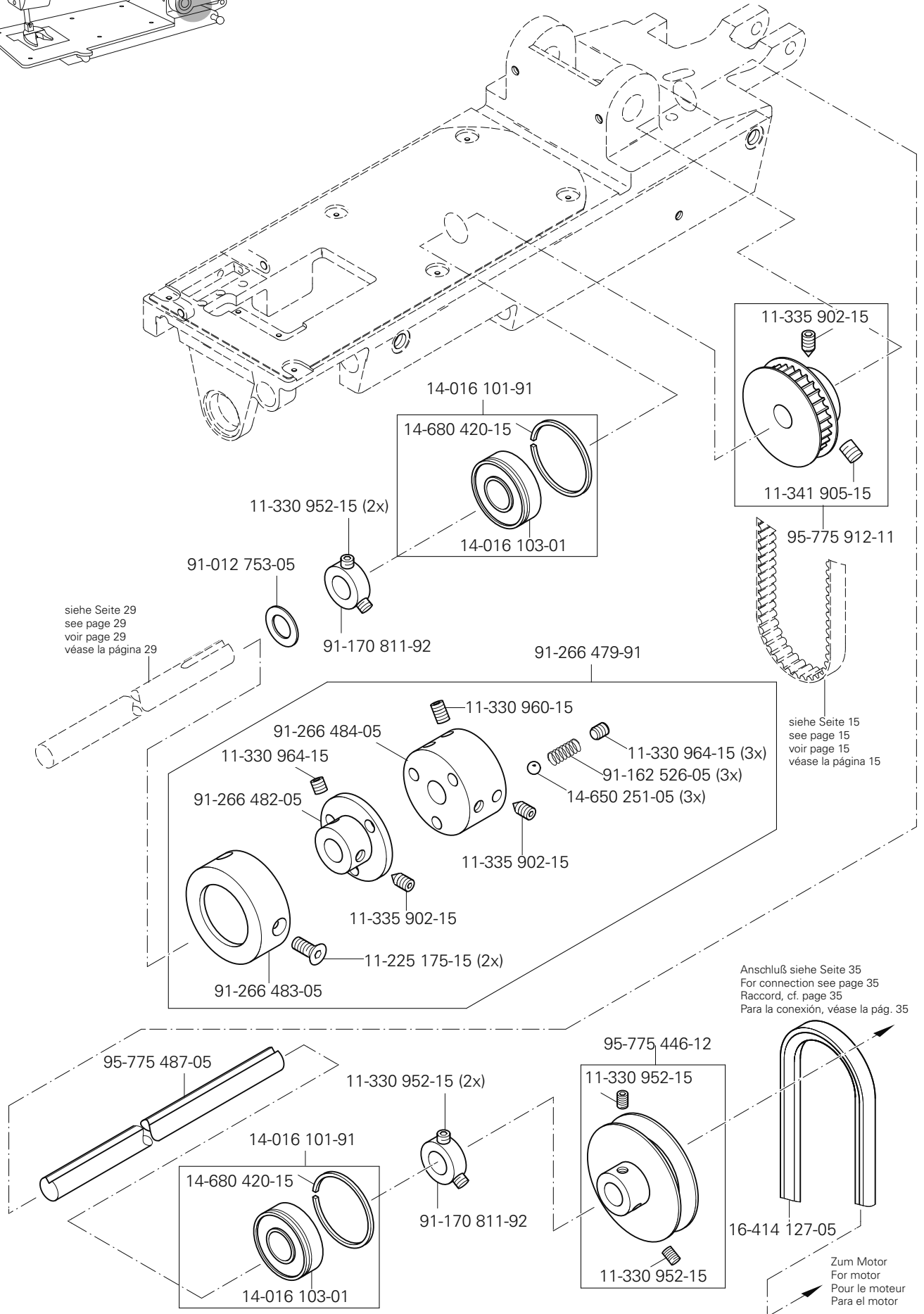

3.04

Grundplattenteile
 Bedplate parts
 Pièces du plateau fondamental
 Piezas del carter

PFAFF 3588-05/020

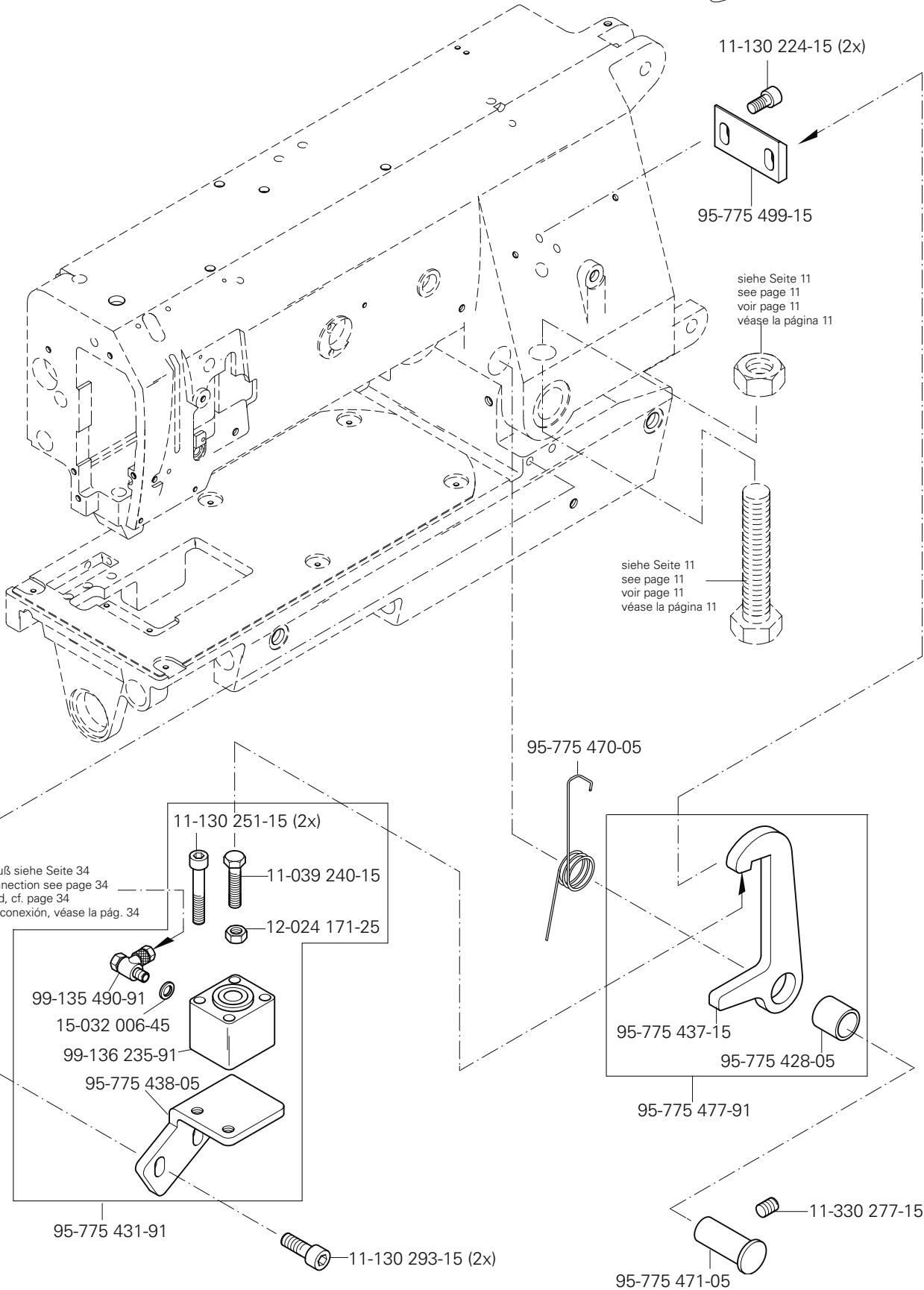
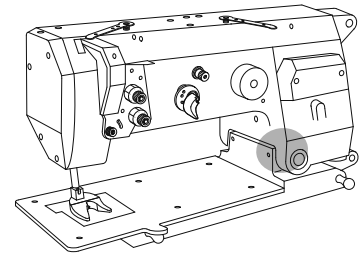

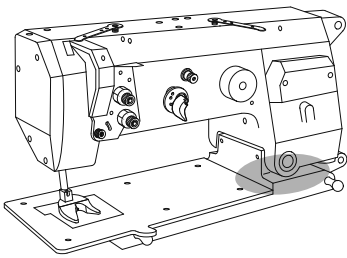

Grundplattenteile
 Bedplate parts
 Pièces du plateau fondamental
 Piezas del carter

PFAFF 3588-05/020

3.04

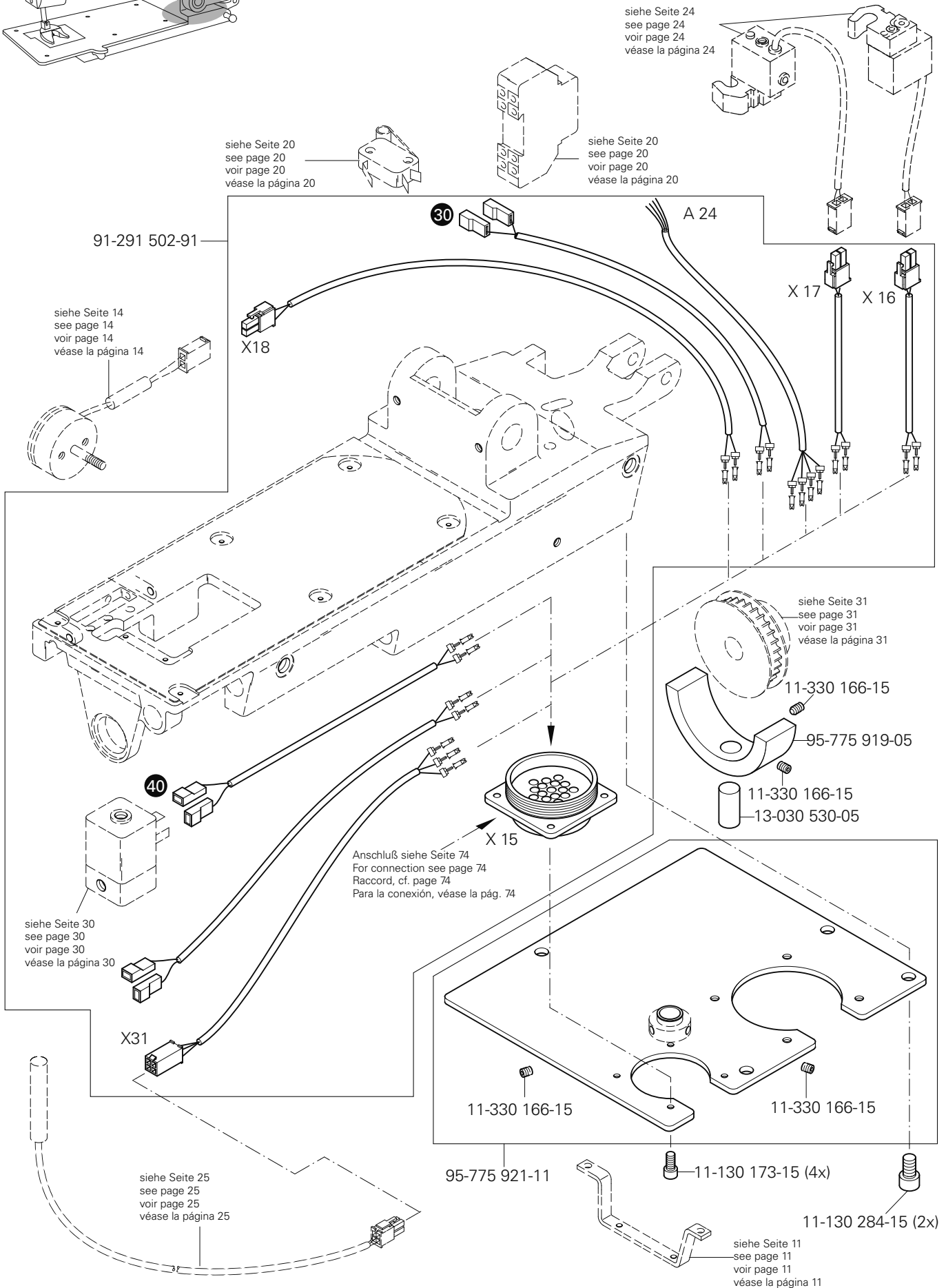

3.04

Grundplattenteile Bedplate parts Pièces du plateau fondamental Piezas del carter

PFAFF 3588-05/020

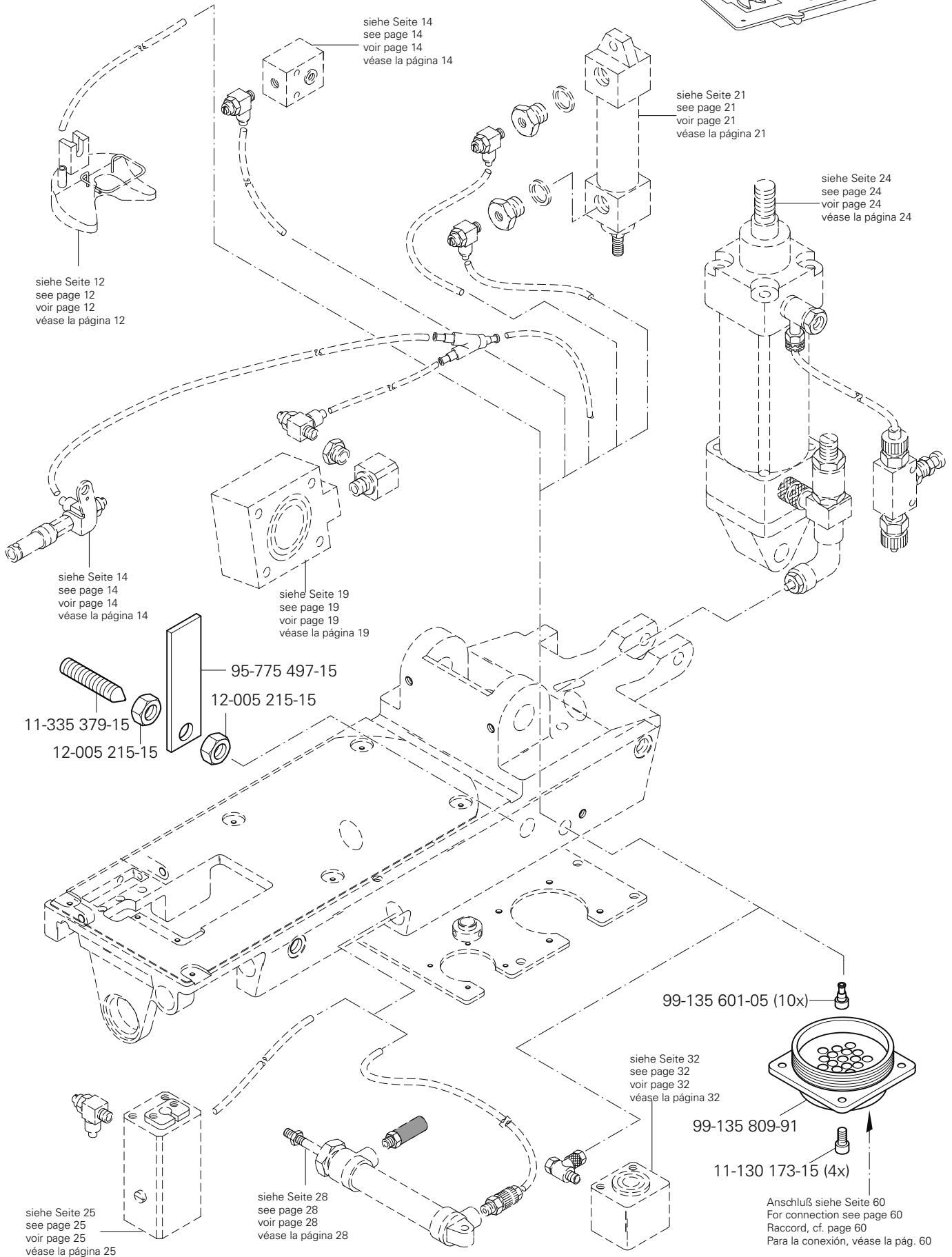
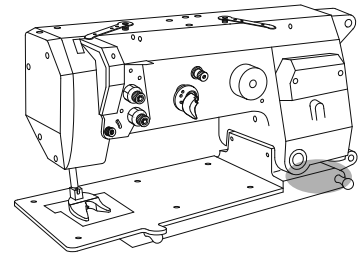

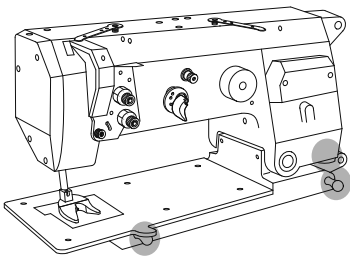

Grundplattenteile
 Bedplate parts
 Pièces du plateau fondamental
 Piezas del carter

PFAFF 3588-05/020

3.04

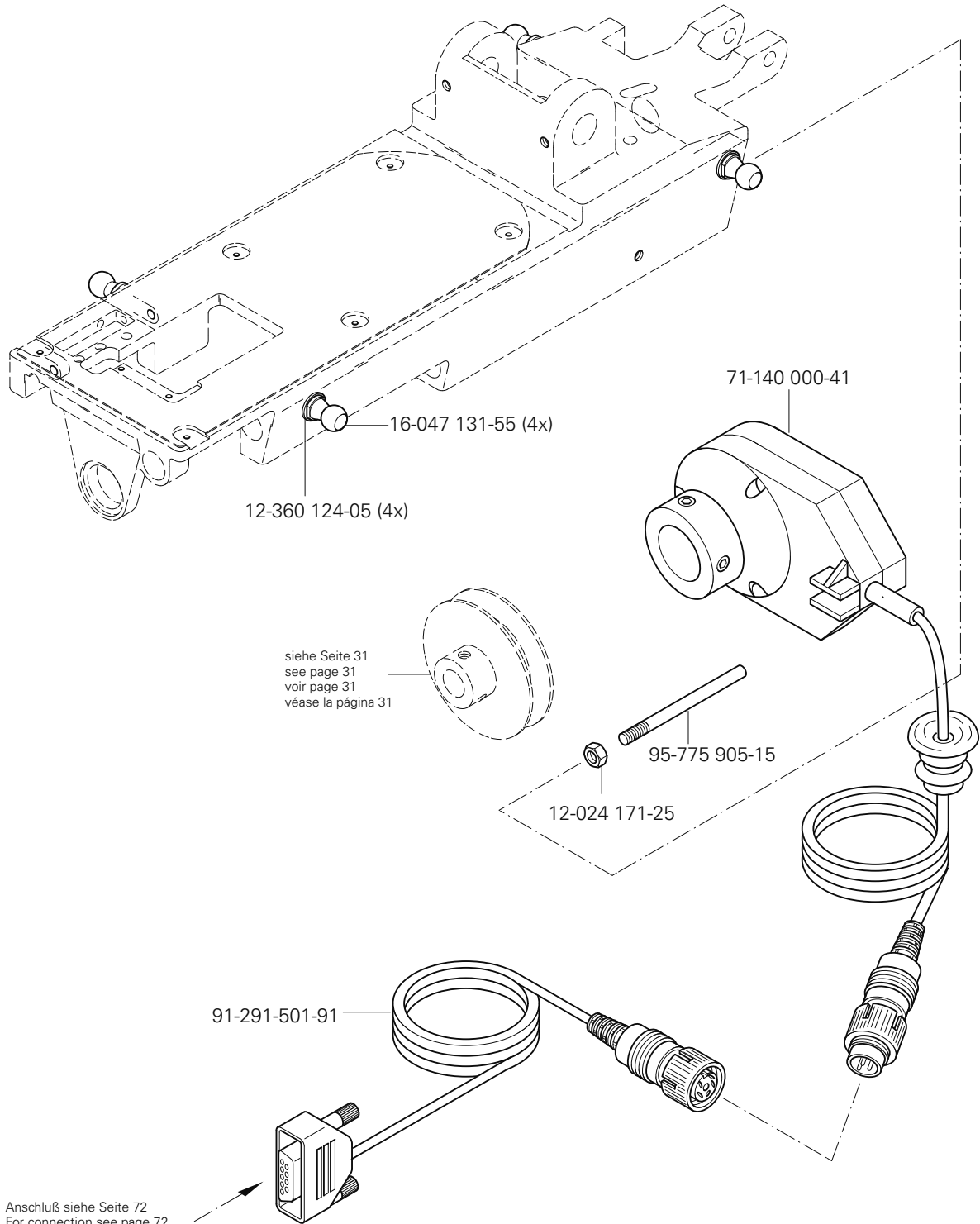

4

Tischplatte
 Table top
 Plateau de table
 Tablero de costure

PFAFF 3588-05/020

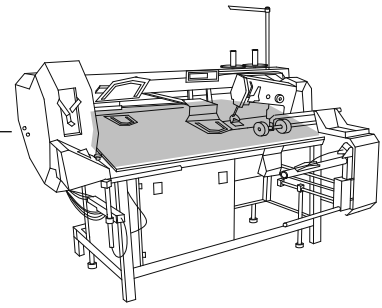

für 3588 -15/020 siehe Seite 89
 for 3588 -15/020 see page 89
 pour 3588 -15/020 voir page 89
 para 3588 -15/020 véase la página 89

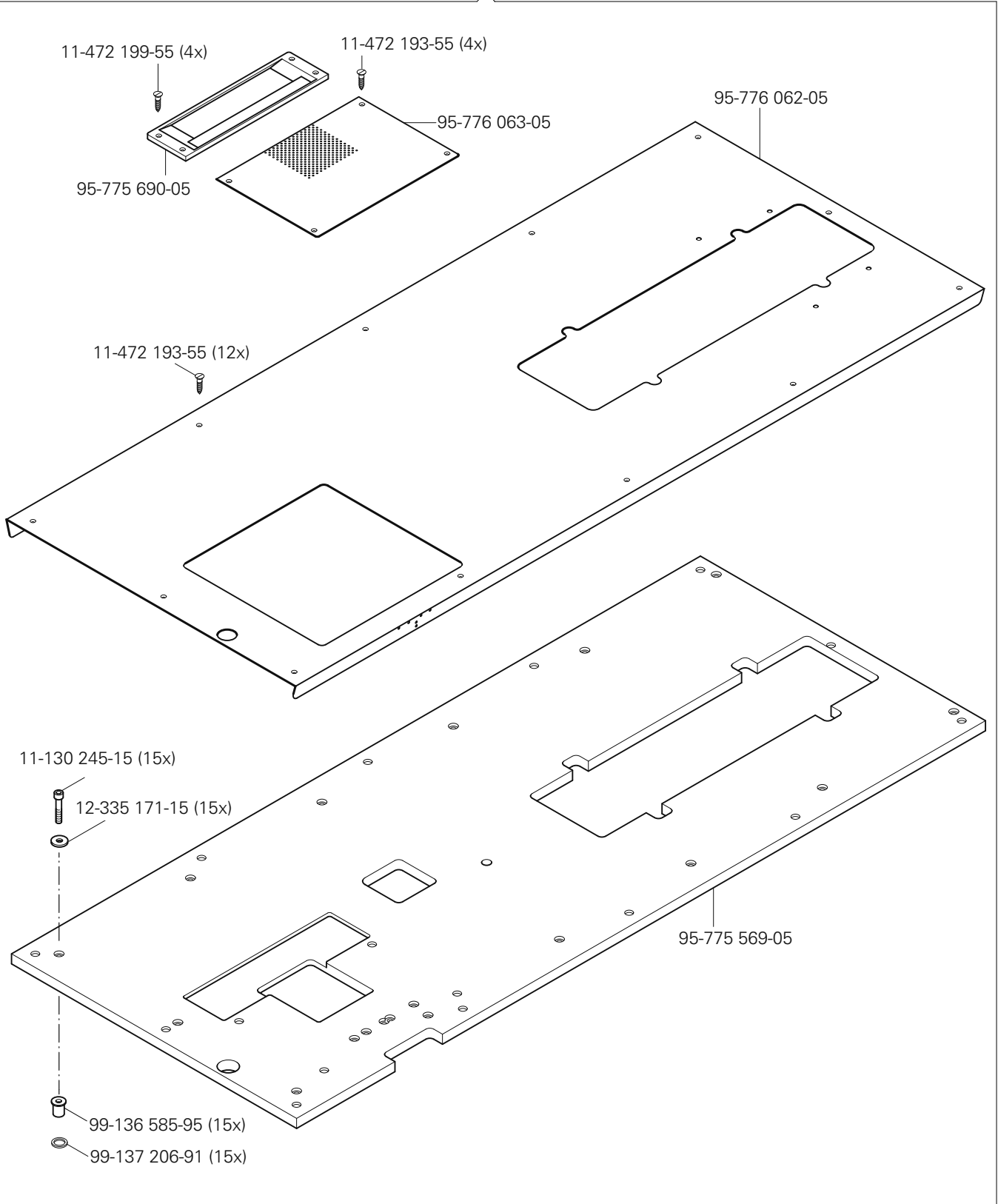

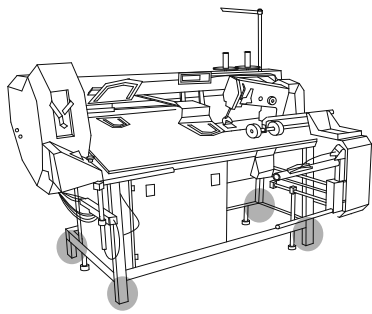

Gestell mit Anbauteilen
 Stand with assembly parts
 Bâti avec éléments de montage
 Barrcada con piezas de montaje

PFAFF 3588-05/020

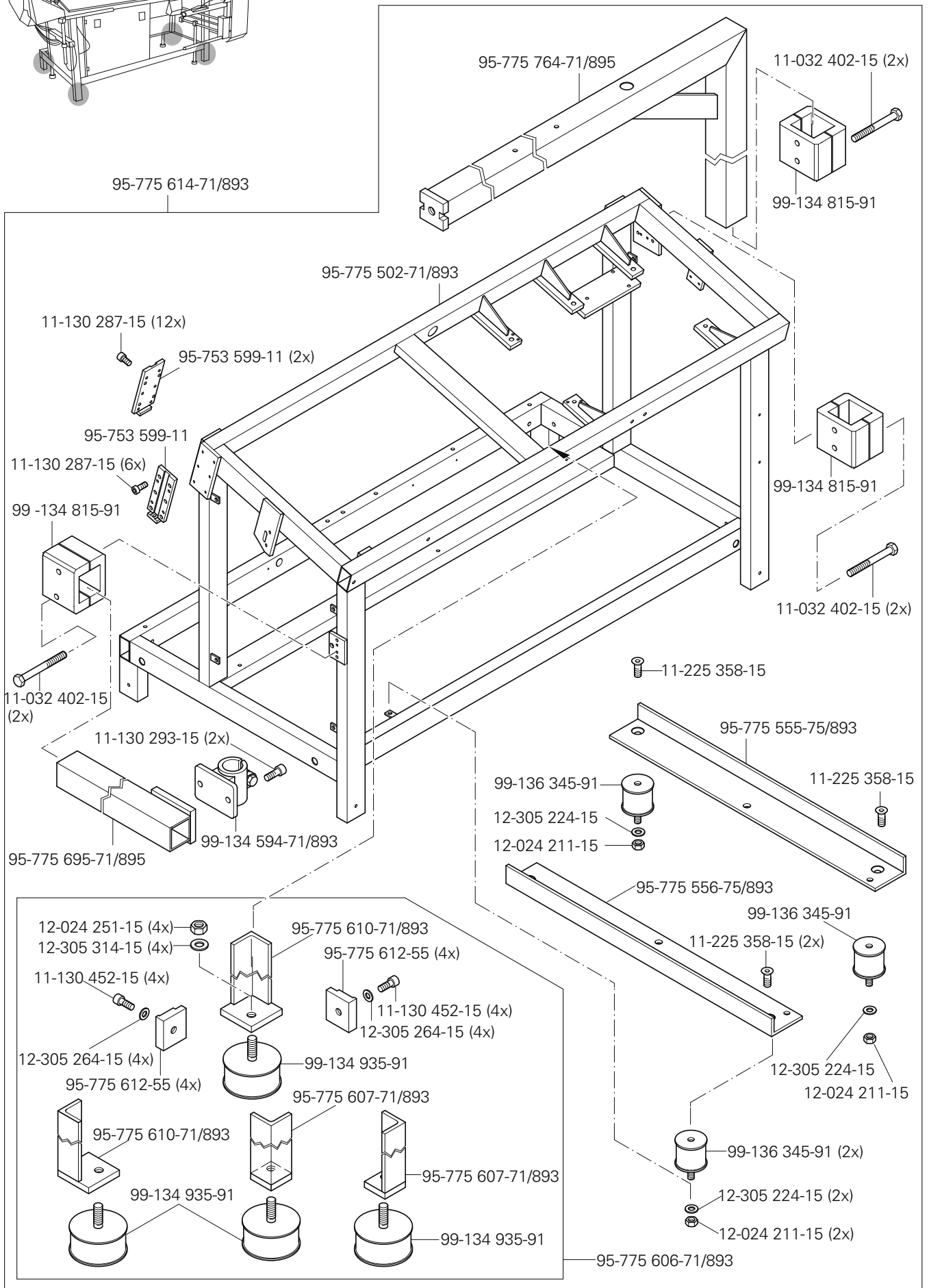

5

Gestell mit Anbauteilen

Stand with assembly parts

Bâti avec éléments de montage

Barrcada con piezas de montaje

PFAFF 3588-05/020

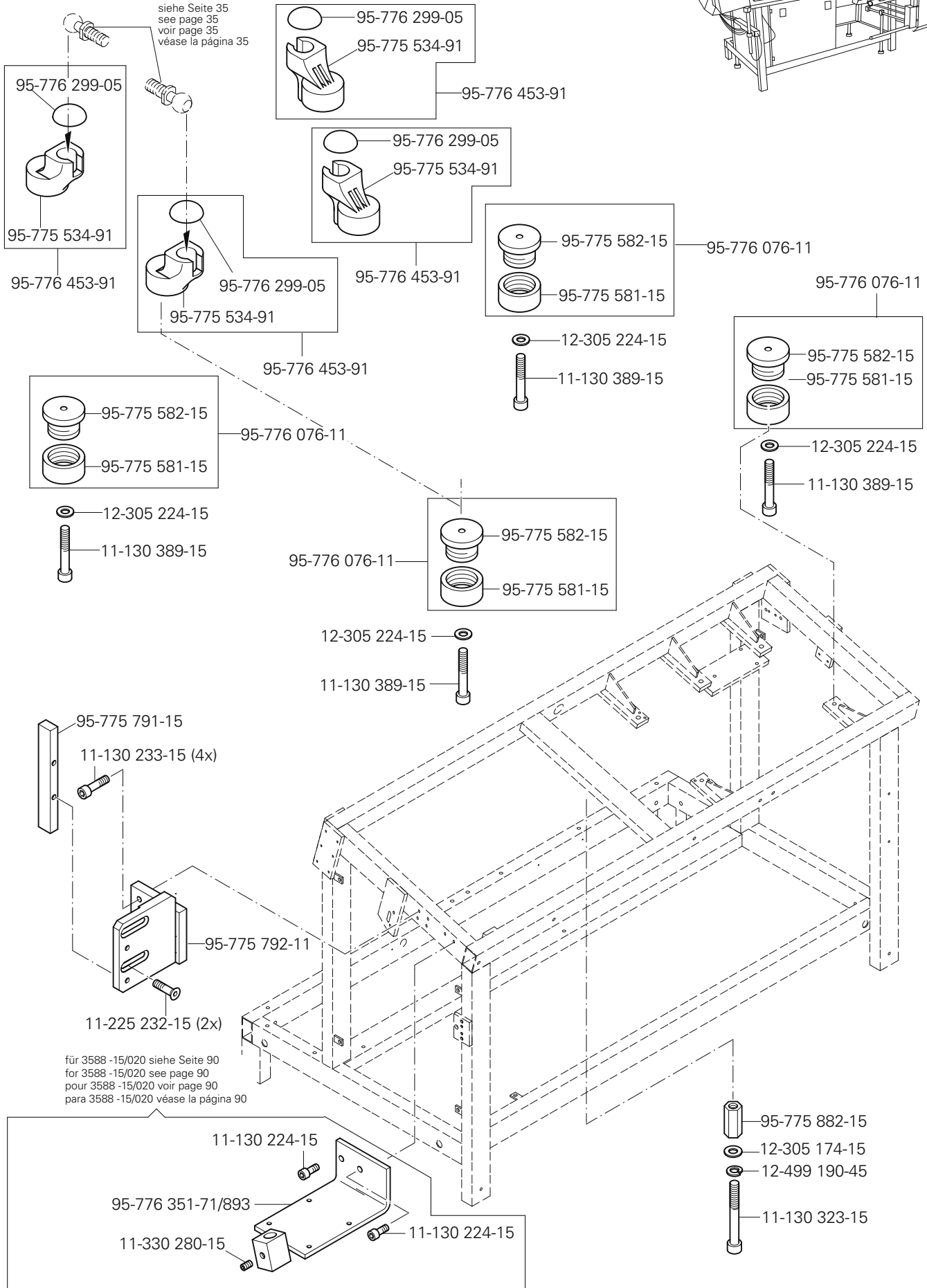
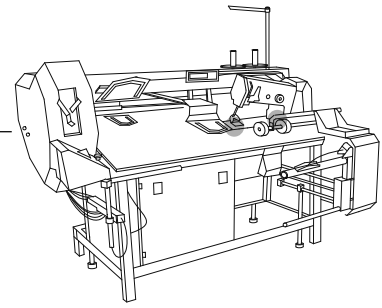

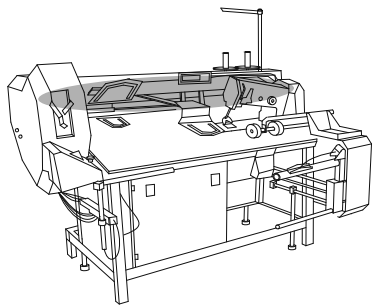

X-Y Antrieb
 X-Y drive
 Système de commande X-Y
 Grupo de accionamiento "X-Y"

PFAFF 3588-05/020

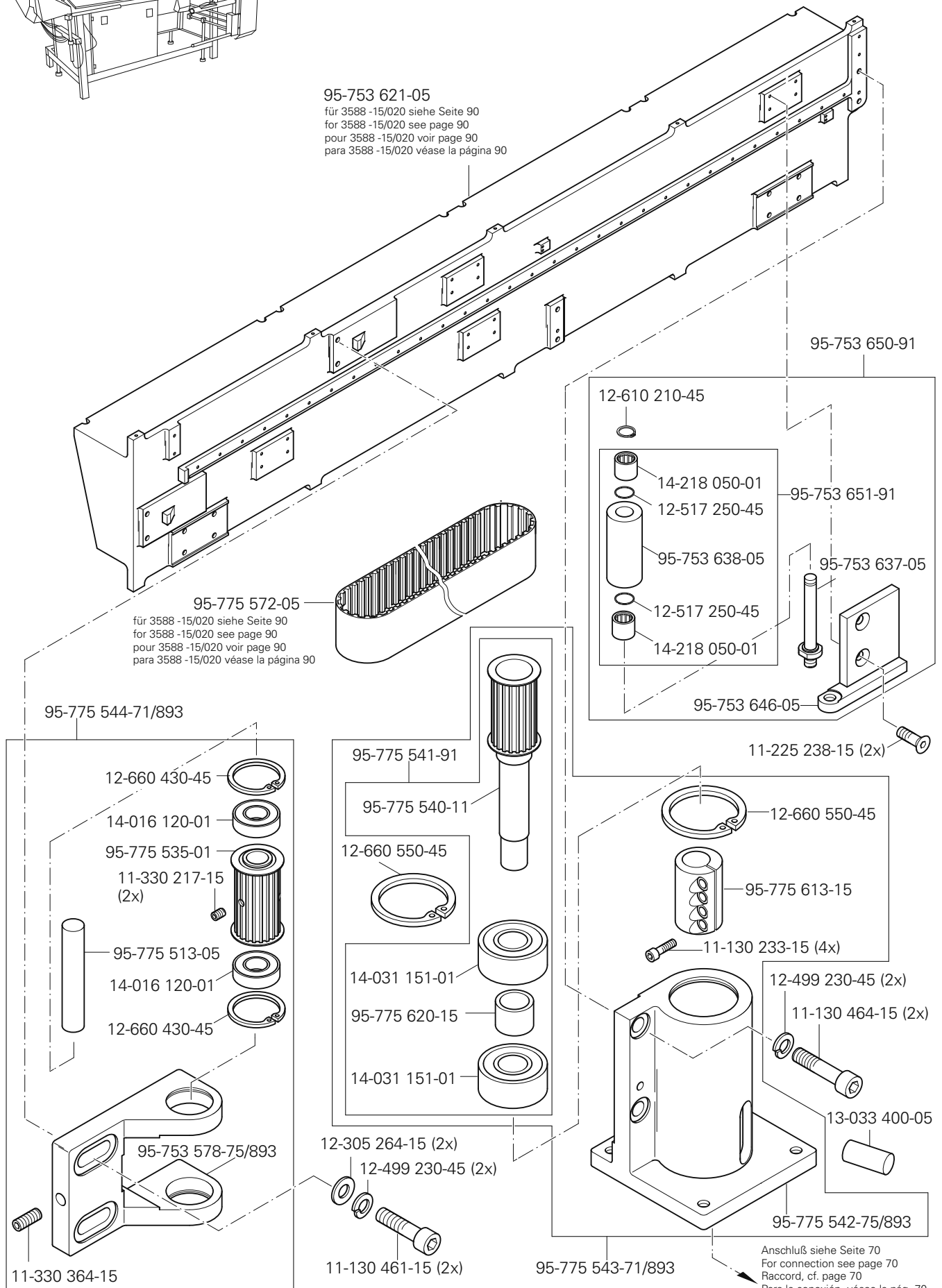

X-Y Antrieb

X-Y drive

Système de commande X-Y

Grupo de accionamiento "X-Y"

PFAFF 3588-05/020

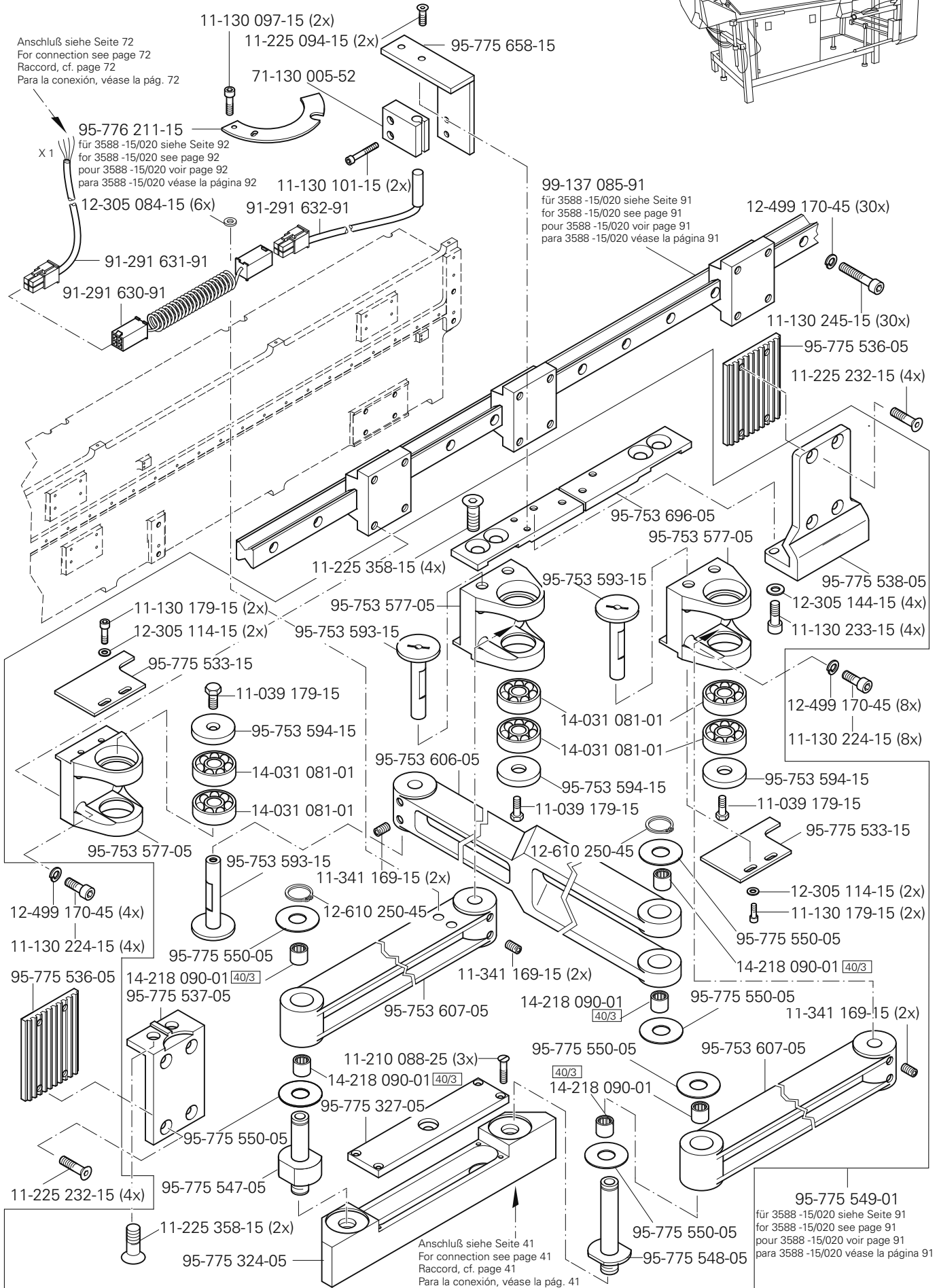
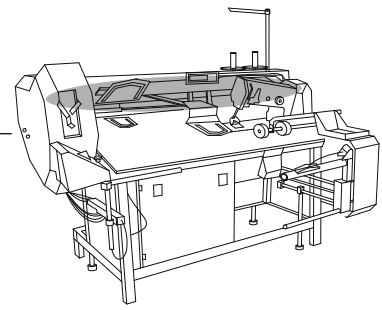

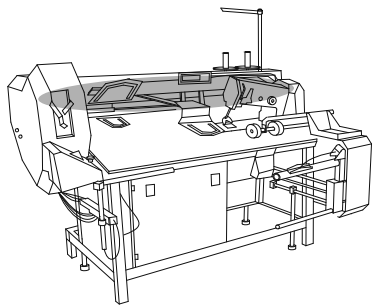

X-Y Antrieb
 X-Y drive
 Système de commande X-Y
 Grupo de accionamiento "X-Y"

PFAFF 3588-05/020

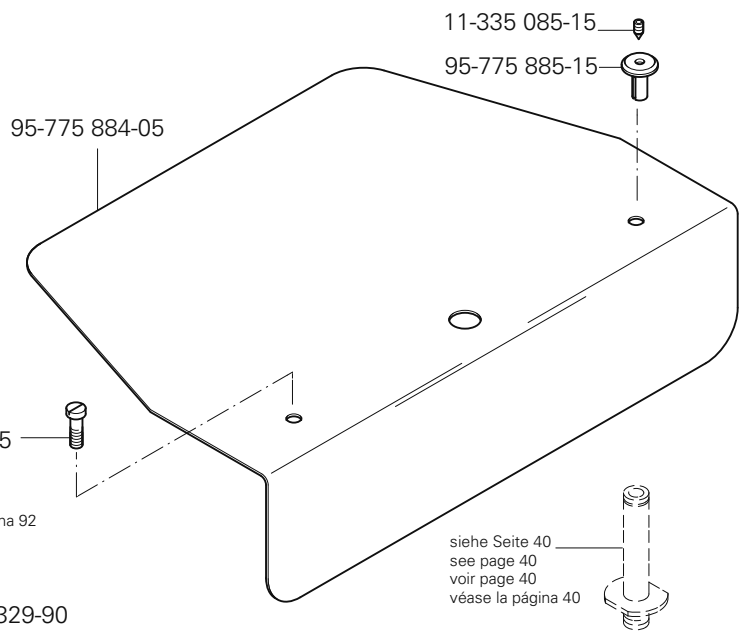

für 3588 -15/020 siehe Seite 92
 for 3588 -15/020 see page 92
 pour 3588 -15/020 voir page 92
 para 3588 -15/020 véase la página 92

siehe Seite 40
 see page 40
 voir page 40
 véase la página 40

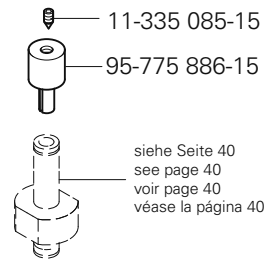
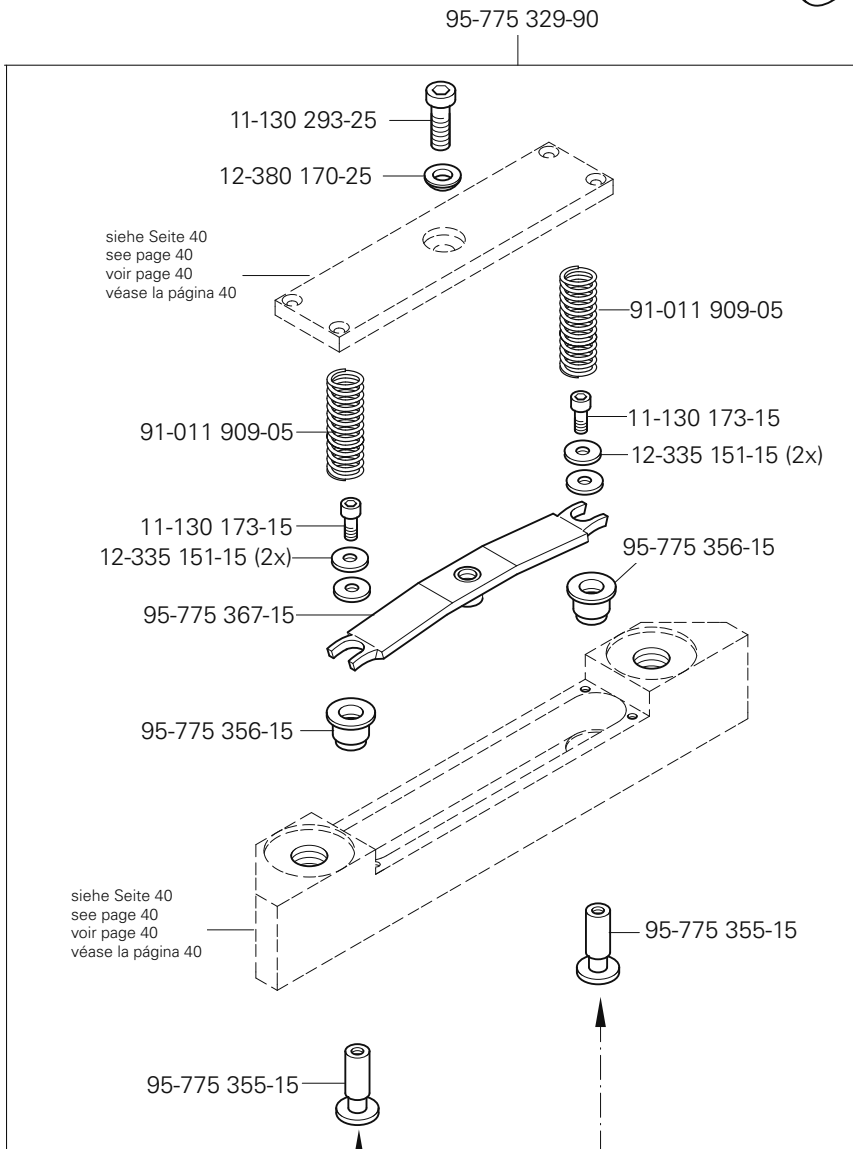

siehe Seite 40
 see page 40
 voir page 40
 véase la página 40

Anschluß siehe Seite 109
 For connection see page 109
 Raccord, cf. page 109
 Para la conexión, véase la pág. 109

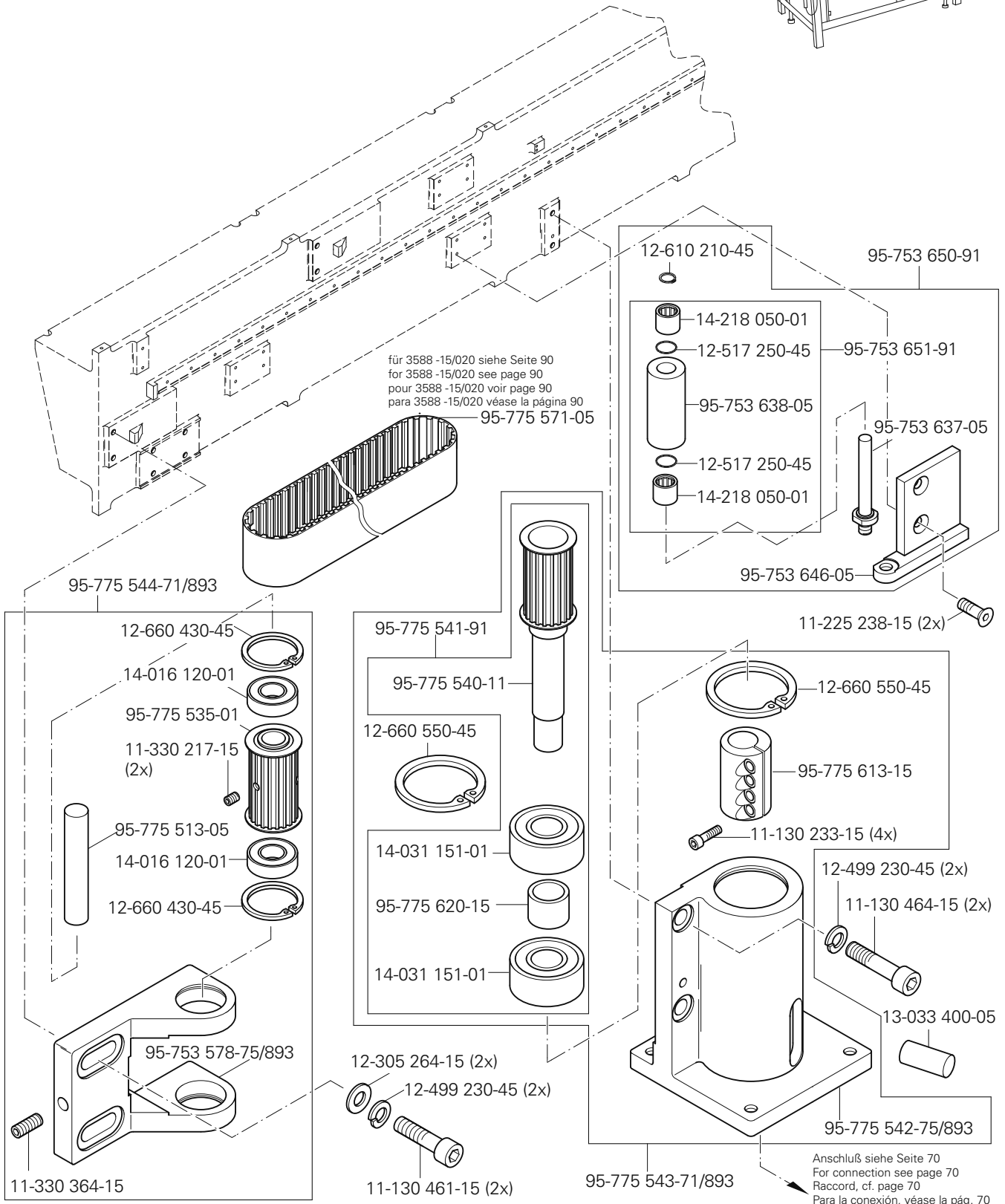
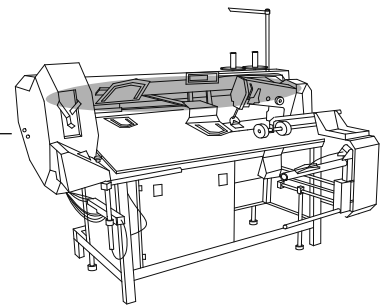

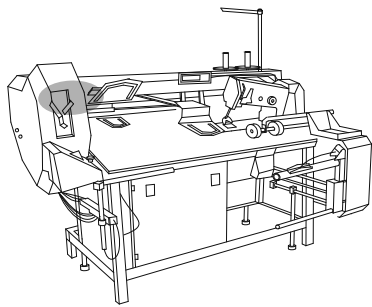

X-Y Antrieb
 X-Y drive
 Système de commande X-Y
 Grupo de accionamiento "X-Y"

PFAFF 3588-05/020

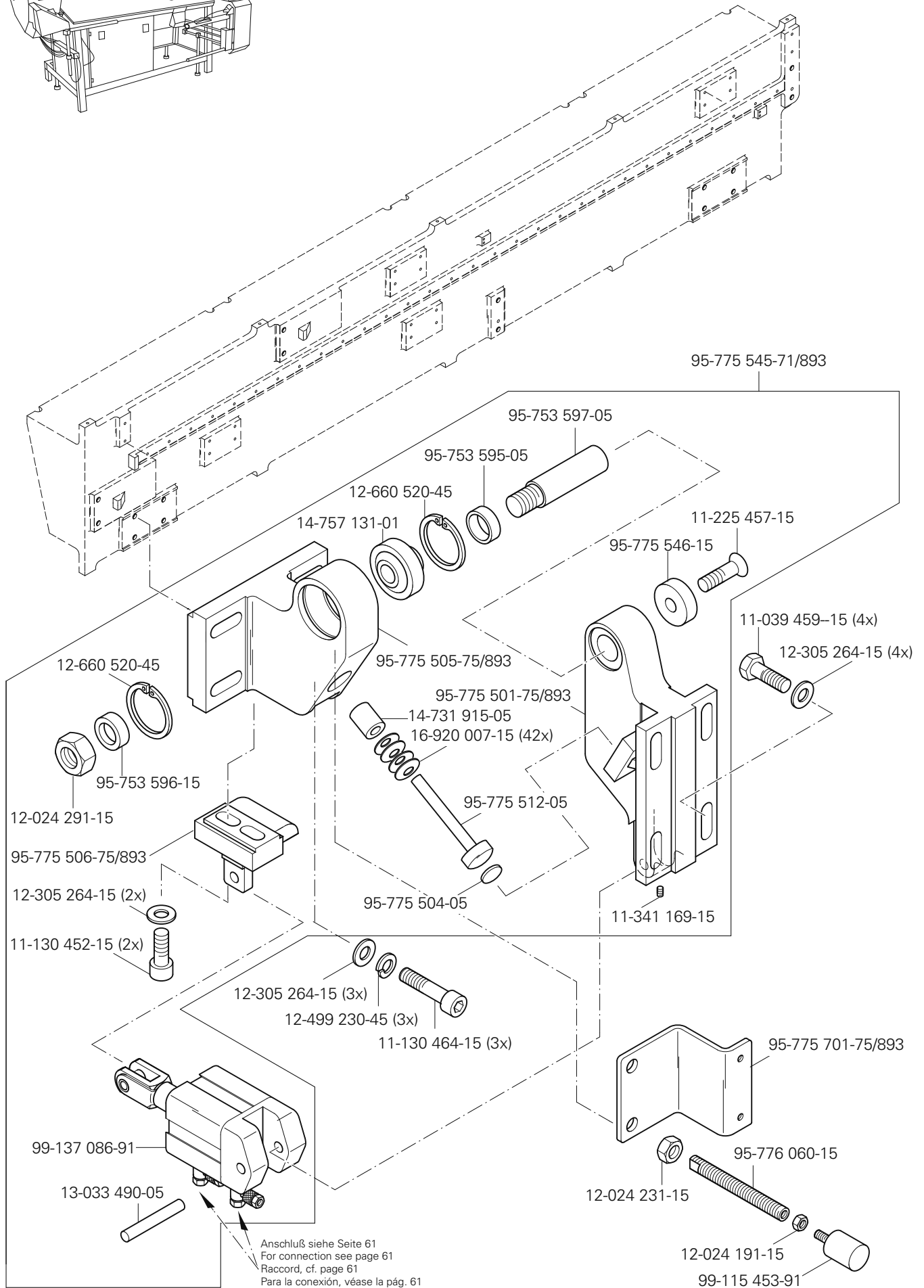

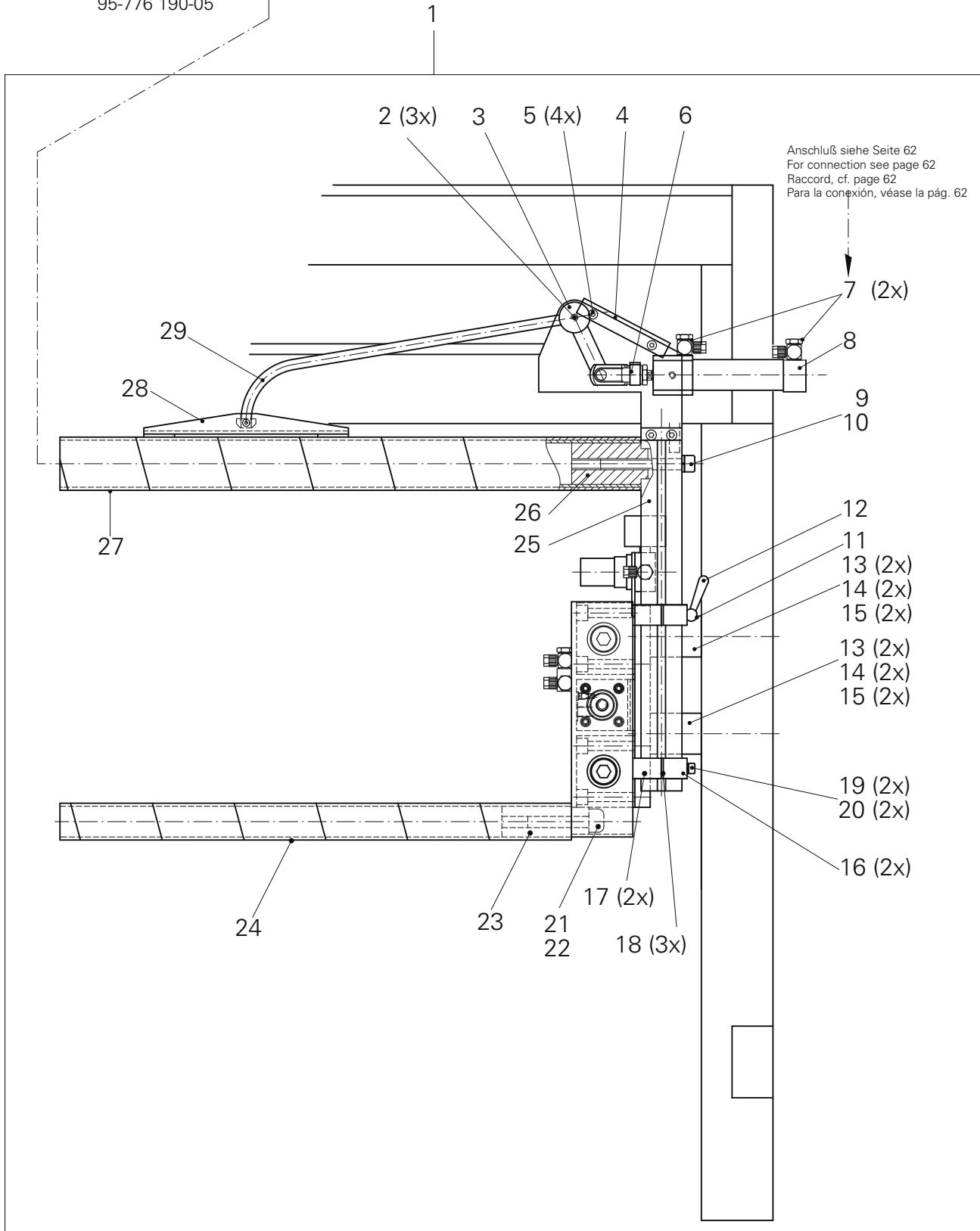
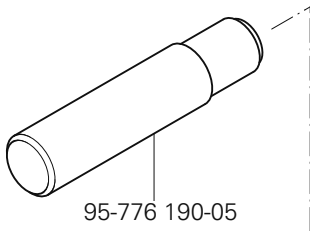
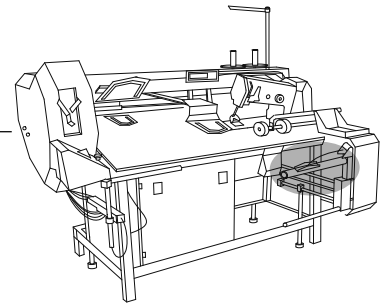

Pos.-Nr. Item No. N° pos. N° de pos.	Bestellnummer Part number N° de commande N° de pedido	Teile-Benennung Description Désignation Denominación	Pos.-Nr. Item No. N° pos. N° de pos.	Bestellnummer Part number N° de commande N° de pedido	Teile-Benennung Description Désignation Denominación
1	95-775 622-71/895	Stapler Stacker Empileur Apilador	16	95-215 040-13/535	Führung 20 x 24 x 60 Guide Guide Guía
2	11-330 280-15	Gewindestift M6 x 8 Threaded stud Vis sans tête Tornillo prisionero	17	95-215 040-13/591	Führung 20 x 27 x 60 Guide Guide Guía
3	95-215 040-14/141	Klemmstück Clamping piece Pièce de serrage Pieza presora	18	95-215 040-14/136	Distanzstück Spacer Pièce d'écartement Pieza distanciadora
4	95-215 040-13/878	Deckel Cover Couvercle Tapa	19	11-130 332-15	Zylinderschraube M6 x 65 Pan-head screw Vis à tête cylindrique Tornillo cilíndrico
5	11-130 906-15	Zylinderschraube M5 x 6 Pan-head screw Vis à tête cylindrique Tornillo cilíndrico	20	12-501 190-45	Federring 6 Spring washer Rondelle élastique Arandela elástica
6	95-215 000-00/635	Gabelkopf Fork head Fourche Cabeza horquillada	21	11-130 719-15	Zylinderschraube M16 x 40 Pan-head screw Vis à tête cylindrique Tornillo cilíndrico
7	95-215 080-18/008	Drosselrückschlagventil 1/8" Check-return valve Clapet anti-retour avec étranglement Válvula estranguladora de retroceso	22	12-499 290-45	Federring 16 Spring washer Rondelle élastique Arandela elástica
8	95-215 000-03/992	Zylinder, doppeltwirkend Cylinder, double-acting Vérin à double effet Cilindro de doble efecto	23	95-215 040-14/132	Rohrverbindung 27 x 40 Tube connection Raccord de tuyaux Unión de tubos
9	11-130 551-15	Zylinderschraube M12 x 40 Pan-head screw Vis à tête cylindrique Tornillo cilíndrico	24	95-215 040-13/923	Rohr Tube Tube Tubo
10	95-215 070-05/901	Federring 12 Spring washer Rondelle élastique Arandela elástica	25	95-215 040-14/134	Klemmstück 40 x 40 x 343 Clamping piece Pièce de serrage Pieza presora
11	95-215 040-12/556	Gewindestift M6 x 79 Threaded stud Vis sans tête Tornillo prisionero	26	95-215 040-14/133	Rohrverbindung 42 x 58 Tube connection Raccord de tuyaux Unión de tubos
12	95-215 080-29/013	Klemmhebel Clamp lever Lever de serrage Palanca de fricción	27	95-215 040-13/921	Rohr Tube Tube Tubo
13	95-215 040-14/146	Distanzstück Spacer Pièce d'écartement Pieza distanciadora	28	95-215 040-14/143	Niederhalter Retainer Serre-ouvrage Sujetatelas
14	11-130 482-15	Zylinderschraube M10 x 70 Pan-head screw Vis à tête cylindrique Tornillo cilíndrico	29	95-215 040-12/561	Schwenkarm Swivel arm Bras oscillant Brazo giratorio
15	12-501 230-45	Federring 10 Spring washer Rondelle élastique Arandela elástica	30	95-215 040-13/877	Blech Plate Tôle Chapa



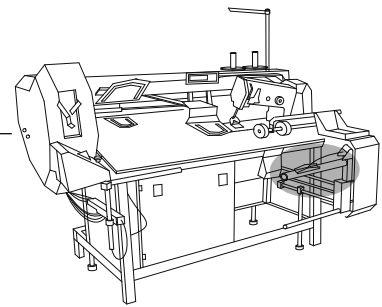

1 für 3588 -15/020 siehe Seite 93
for 3588 -15/020 see page 93
pour 3588 -15/020 voir page 93
para 3588 -15/020 véase la página 93

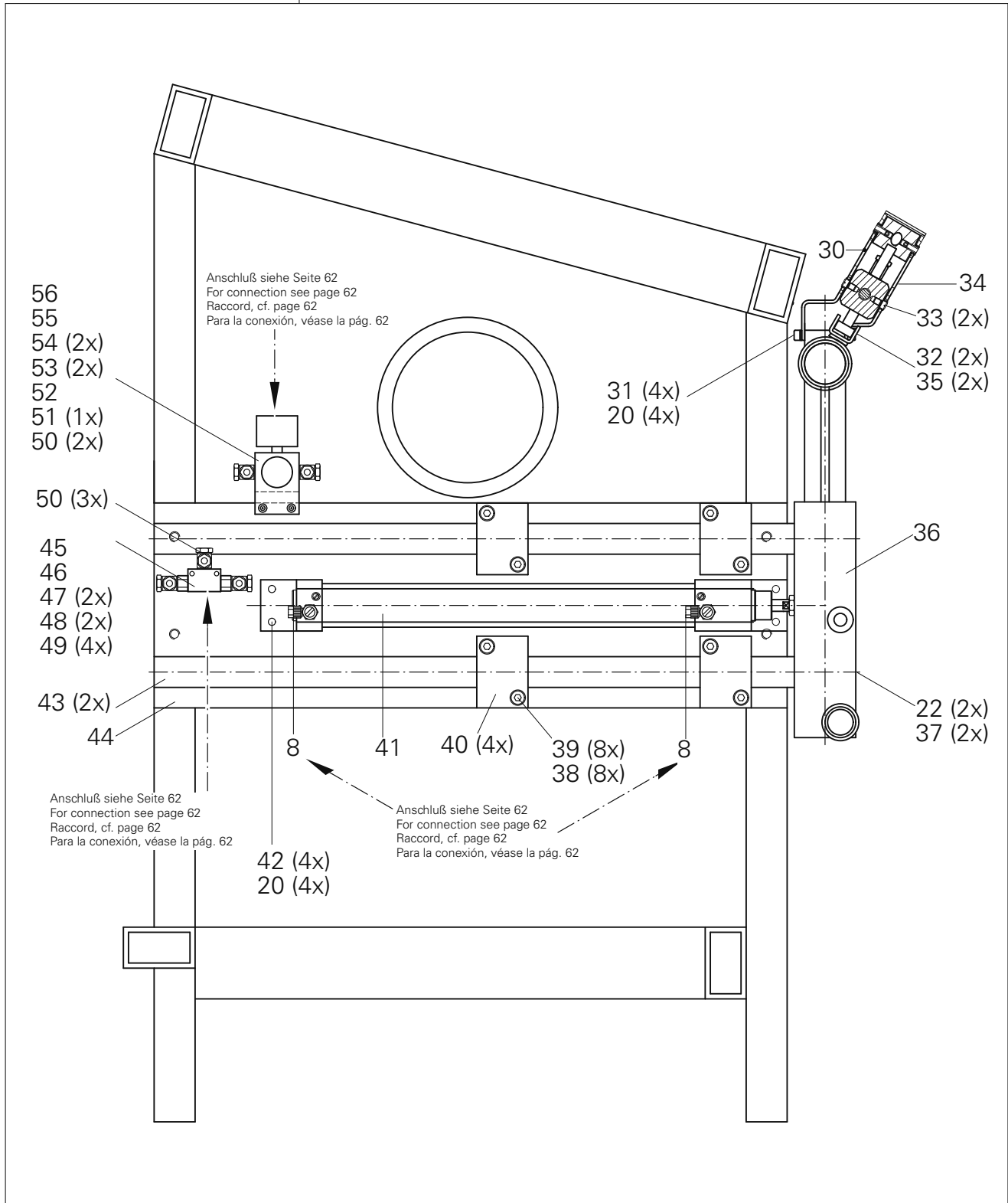

Pos.-Nr. Item No. N° pos. N° de pos.	Bestellnummer Part number N° de commande N° de pedido	Teile-Benennung Description Désignation Denominación	Pos.-Nr. Item No. N° pos. N° de pos.	Bestellnummer Part number N° de commande N° de pedido	Teile-Benennung Description Désignation Denominación
31	11-130 293-15	Zylinderschraube M6 x 16 Pan-head screw Vis à tête cylindrique Tornillo cilíndrico	46	95-215 040-14/161	Distanzklotz Spacing block Bloc d'écartement Taco distanciador
32	11-225 220-15	Senkschraube M5 x 8 Countersunk screw Vis à tête noyée Tornillo avellanado	47	11-130 179-15	Zylinderschraube M4 x 12 Pan-head screw Vis à tête cylindrique Tornillo cilíndrico
33	95-215 040-18/505	Paßschraube M 6 Shouldered screw Vis de précision Tornillo de ajuste	48	11-130 191-15	Zylinderschraube M4 x 20 Pan-head screw Vis à tête cylindrique Tornillo cilíndrico
34	95-215 040-13/880	Blech Plate Tôle Chapa	49	12-501 150-45	Federring 4 Spring washer Rondelle élastique Arandela elástica
35	12-505 171-15	Federscheibe B5 Spring washer Rondelle élastique Arandela elástica	50	95-215 080-18/102	Schwenkverschraubung Swivel union Raccord pivotant Racora orientable
36	95-215 040-14/135	Klotz 60 x 230 Block Bloc Bloque	51	95-215 080-17/605	Mutter M30 x 1,5 Nut Ecrou Tuerca
37	11-130 719-15	Zylinderschraube M16 x 40 Pan-head screw Vis à tête cylindrique Tornillo cilíndrico	52	95-215 080-17/604	Druckregler Pressure regulator Régulateur de pression Regulador de presión
38	12-501 210-45	Federring 8 Spring washer Rondelle élastique Arandela elástica	53	11-130 227-15	Zylinderschraube M5 x 12 Pan-head screw Vis à tête cylindrique Tornillo cilíndrico
39	11-130 395-15	Zylinderschraube M8 x 60 Pan-head screw Vis à tête cylindrique Tornillo cilíndrico	54	12-501 170-45	Federring 5 Spring washer Rondelle élastique Arandela elástica
40	95-215 040-13/534	Führung Guide Guide Guía	55	95-215 040-15/131	Befestigungsblech Mounting plate Plaque de montage Placa de fijación
41	95-215 000-03/413	Zylinder, doppeltwirkend Cylinder, double-acting Vérin à double effet Cilindro de doble efecto	56	95-215 080-23/601	Verschlusschraube G 1/8 Screw plug Vis d'obturation Tornillo de cierre
42	11-130 299-15	Zylinderschraube M6 x 20 Pan-head screw Vis à tête cylindrique Tornillo cilíndrico			
43	95-215 040-12/569	Führungsstange Guide bar Barre de guidage Barra-guía			
44	95-215 040-14/138	Grundplatte Baseplate Plaque fondamentale Placa base			
45	95-215 080-14/925	Doppelrückschlagventil G1/8 Double-check valve Double valve d'arrêt Doble válvula de retención			



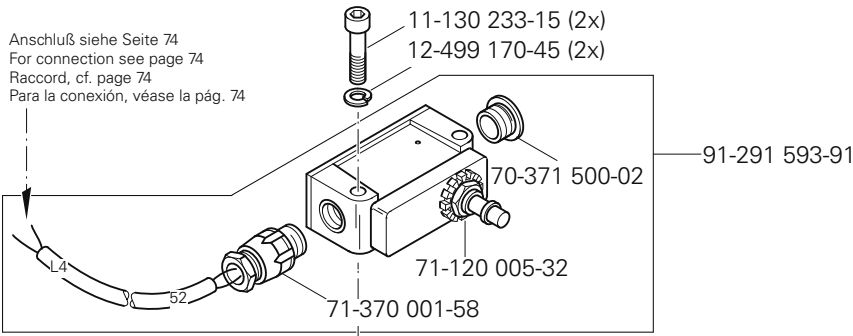
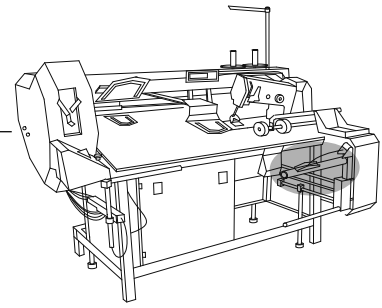

Anschluß siehe Seite 74
For connection see page 74
Raccord, cf. page 74
Para la conexión, véase la pág. 74

für 3588 -15/020 siehe Seite 94
for 3588 -15/020 see page 94
pour 3588 -15/020 voir page 94
para 3588 -15/020 véase la página 94

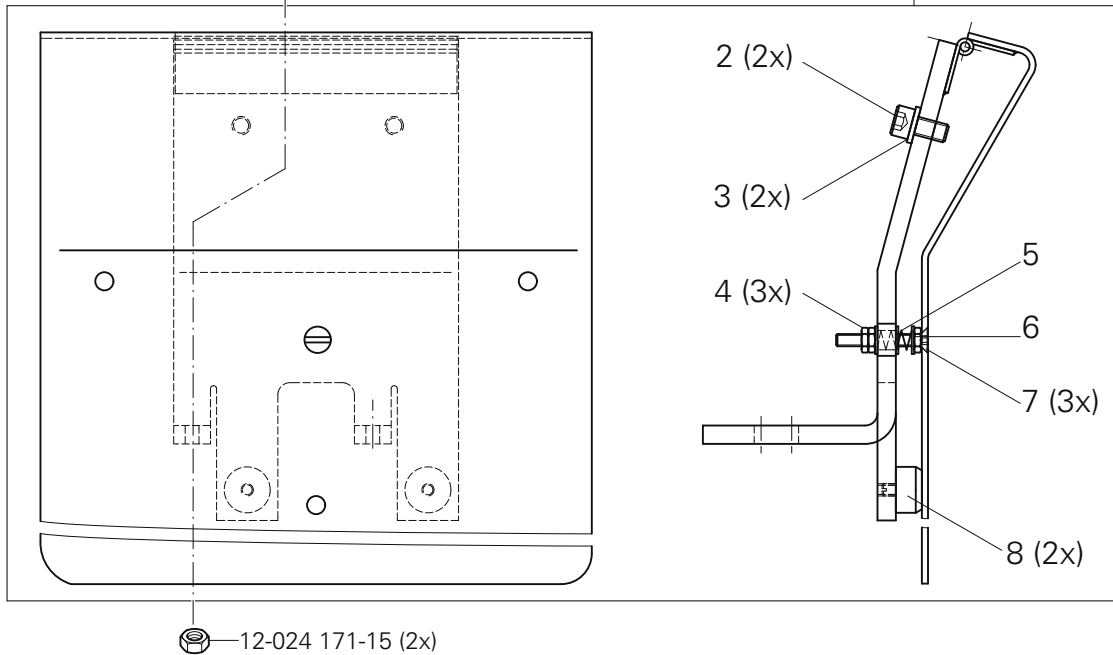

Pos.-Nr. Item No. N° pos. N° de pos.	Bestellnummer Part number N° de commande N° de pedido	Teile-Benennung Description Désignation Denominación	Pos.-Nr. Item No. N° pos. N° de pos.	Bestellnummer Part number N° de commande N° de pedido	Teile-Benennung Description Désignation Denominación
1	95-775 644-71/895	Träger vollst. Bracket assy. Support complet Soporte completo	5	91-022 116-05	Druckfeder Pressure spring Ressort de pression Muelle de presión
2	11-130 287-15	Zylinderschraube M6 x 12 Pan-head screw Vis à tête cylindrique Tornillo cilíndrico	6	11-225 196-15	Senkschraube M4 x 25 Countersunk screw Vis à tête noyée Tornillo avellanado
3	12-305 174-15	Scheibe 6,4 Washer Rondelle Arandela	7	12-305 114-15	Scheibe 4,3 Washer Rondelle Arandela
4	12-024 151-15	Sechskantmutter M4 Hexagon nut Ecrou à six pans Tuerca hexagonal	8	91-024 554-05	Anschlag Stop Butée Tope

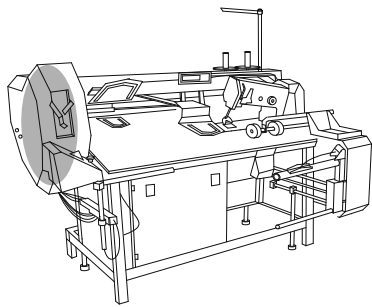

Umbagger
Folder
Remplieur
Grupo dobiador PFAFF 3588-05/020

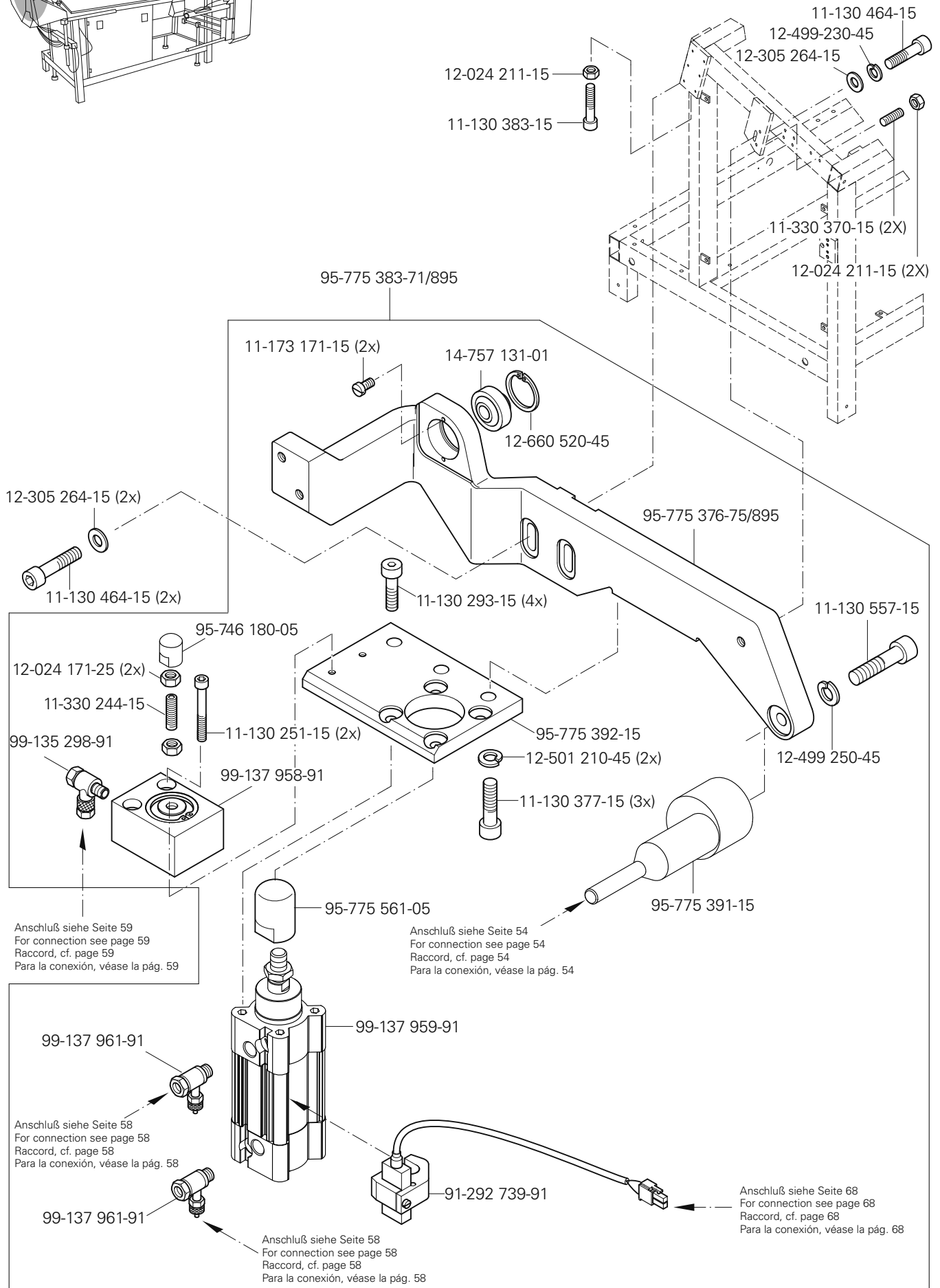

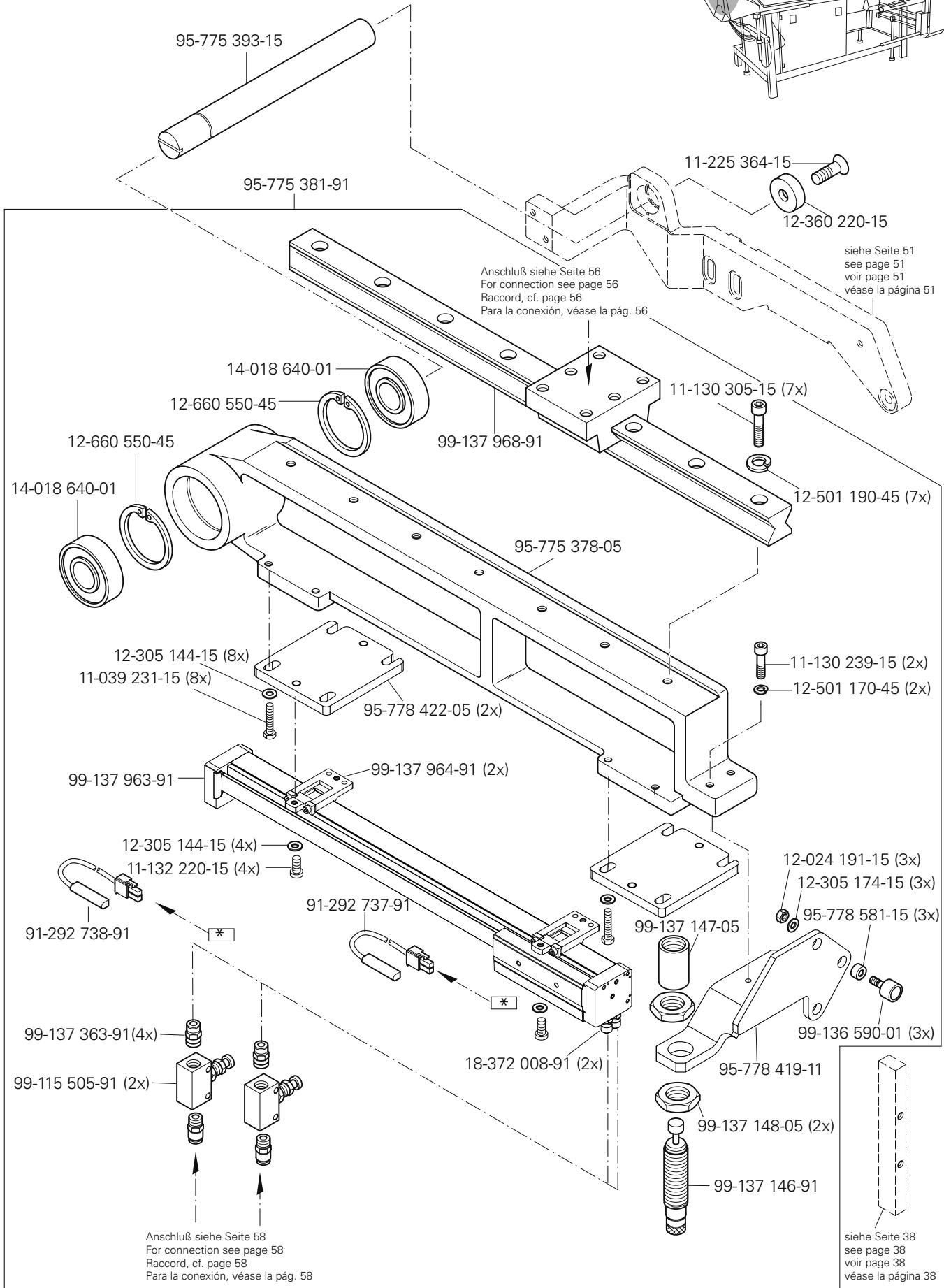
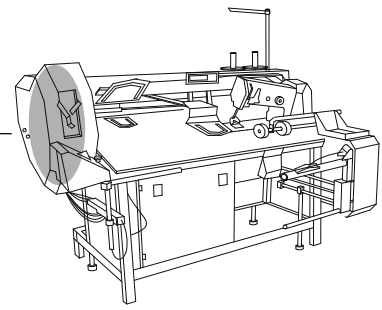

* Anschluß siehe Seite 68
For connection see page 68
Raccord, cf. page 68
Para la conexión, véase la pág. 68

☐ siehe Kapitel 2 Erläuterung der Schlüsselzeichen
see chapter 2 Explanation of key markings
voir le chap. 2 Explication des symboles
véase el Cap. 2 Explicaciones de los signos clave

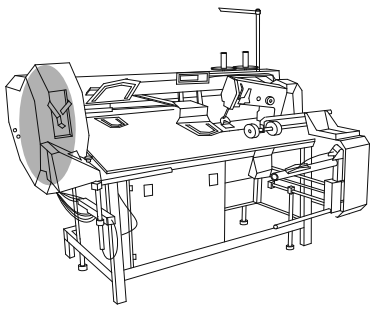

Umbagger
Folder
Remplieur
Grupo dobiador PFAFF 3588-05/020

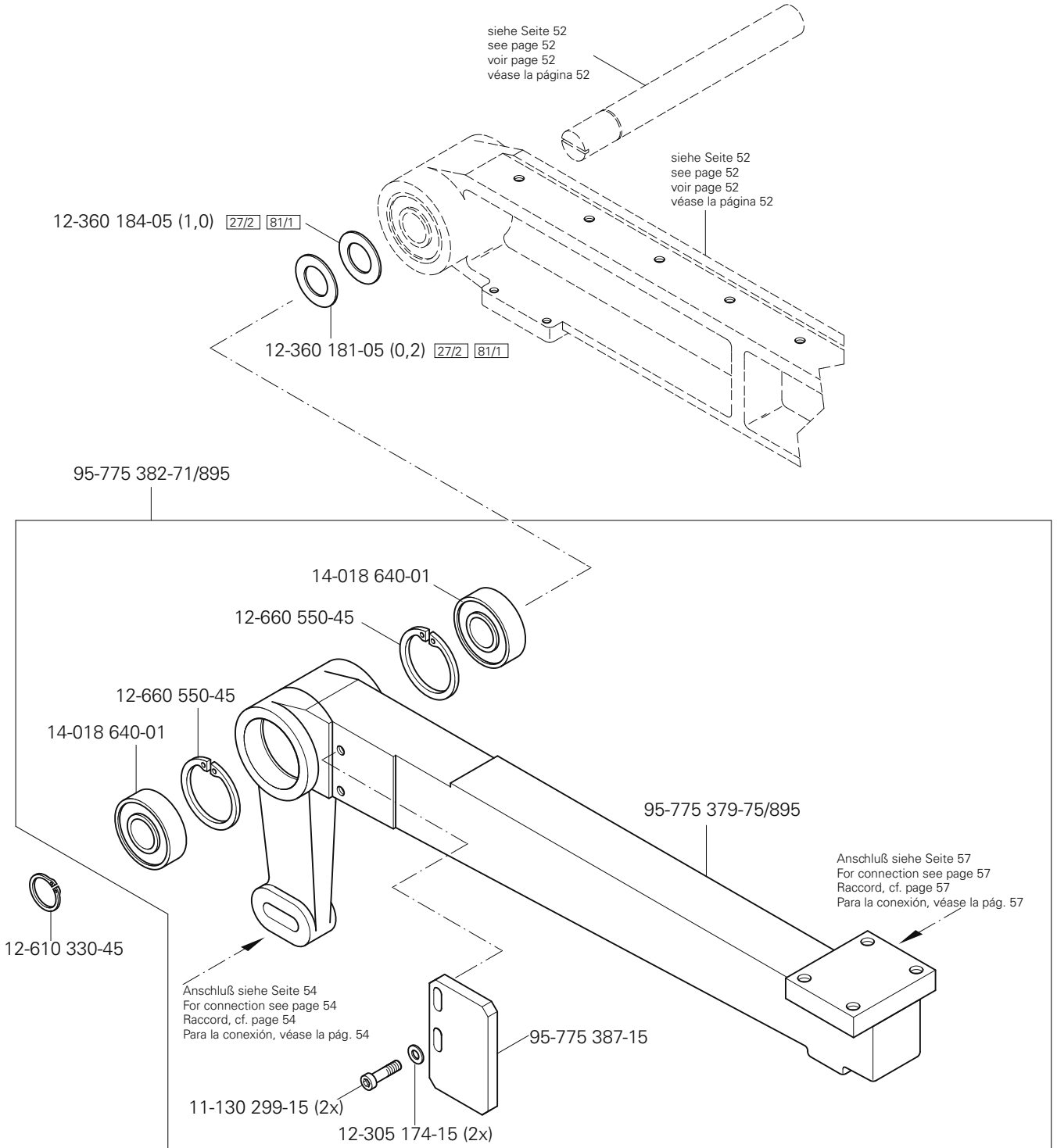

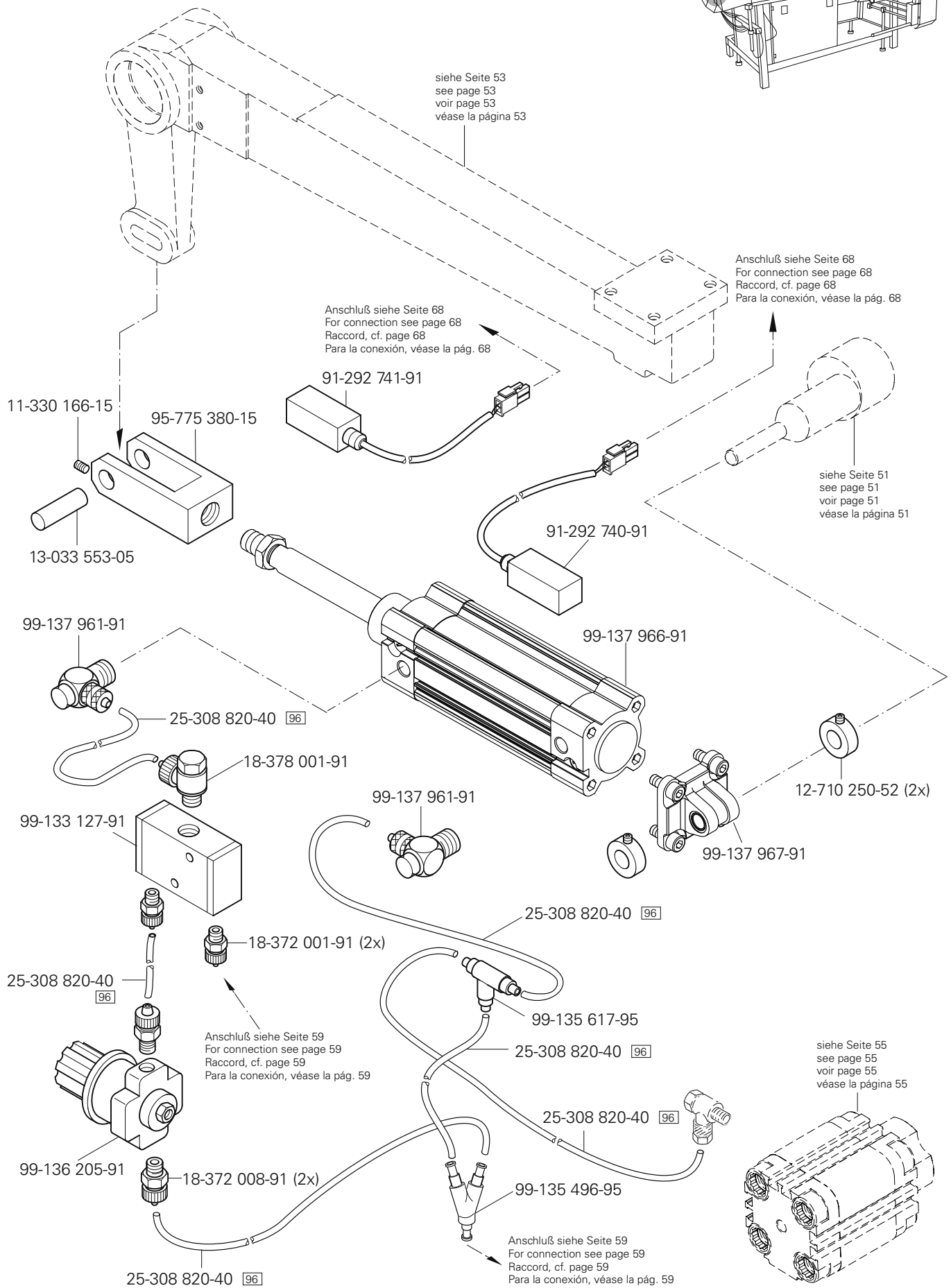
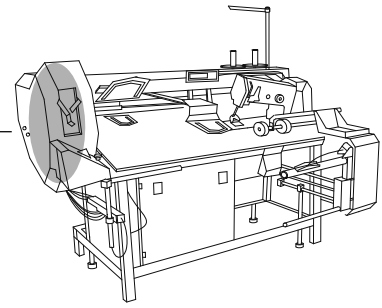

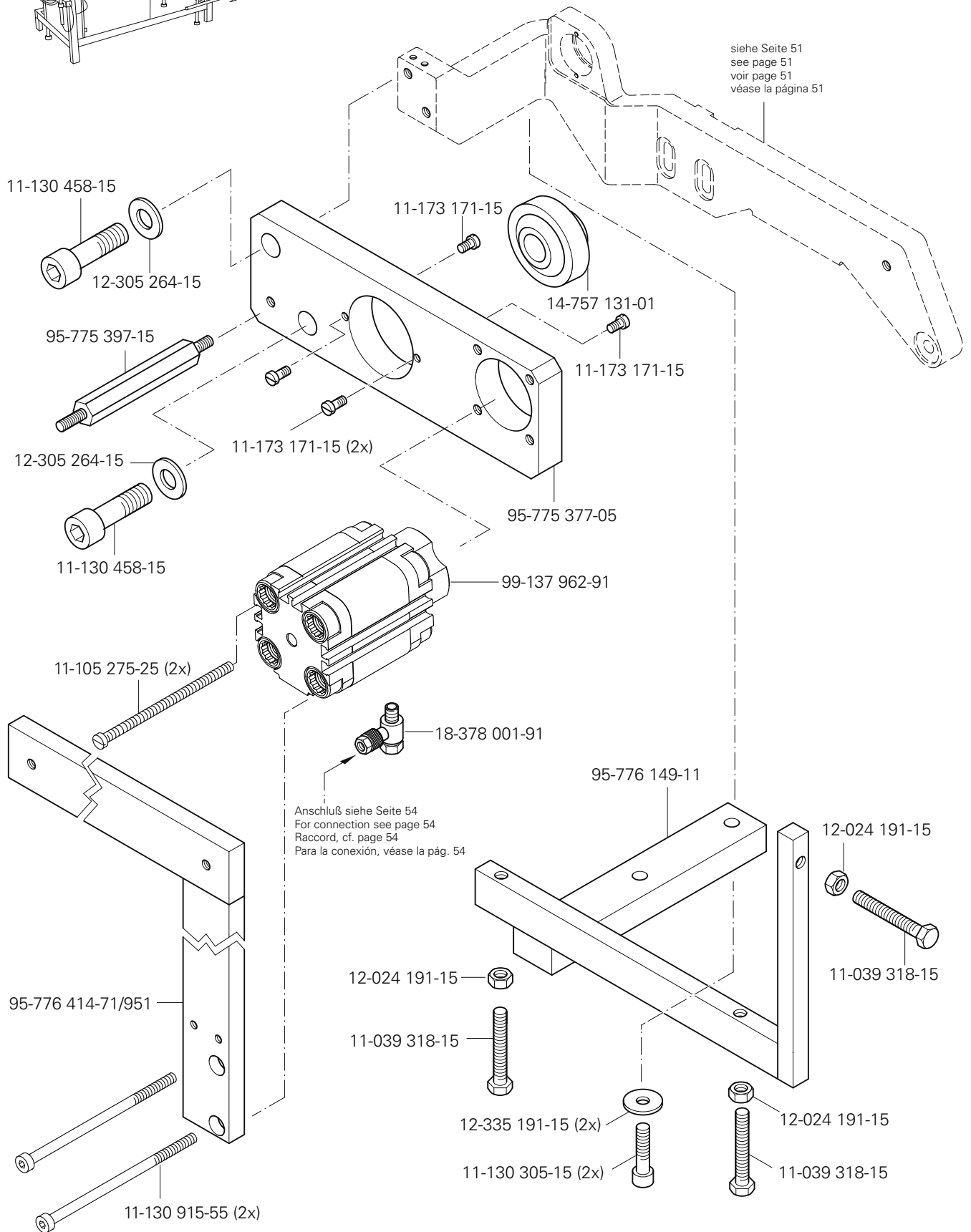
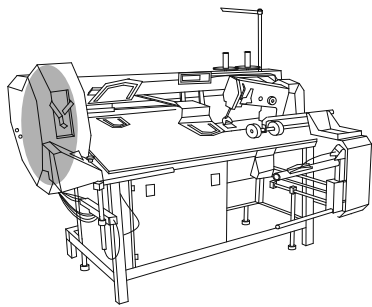

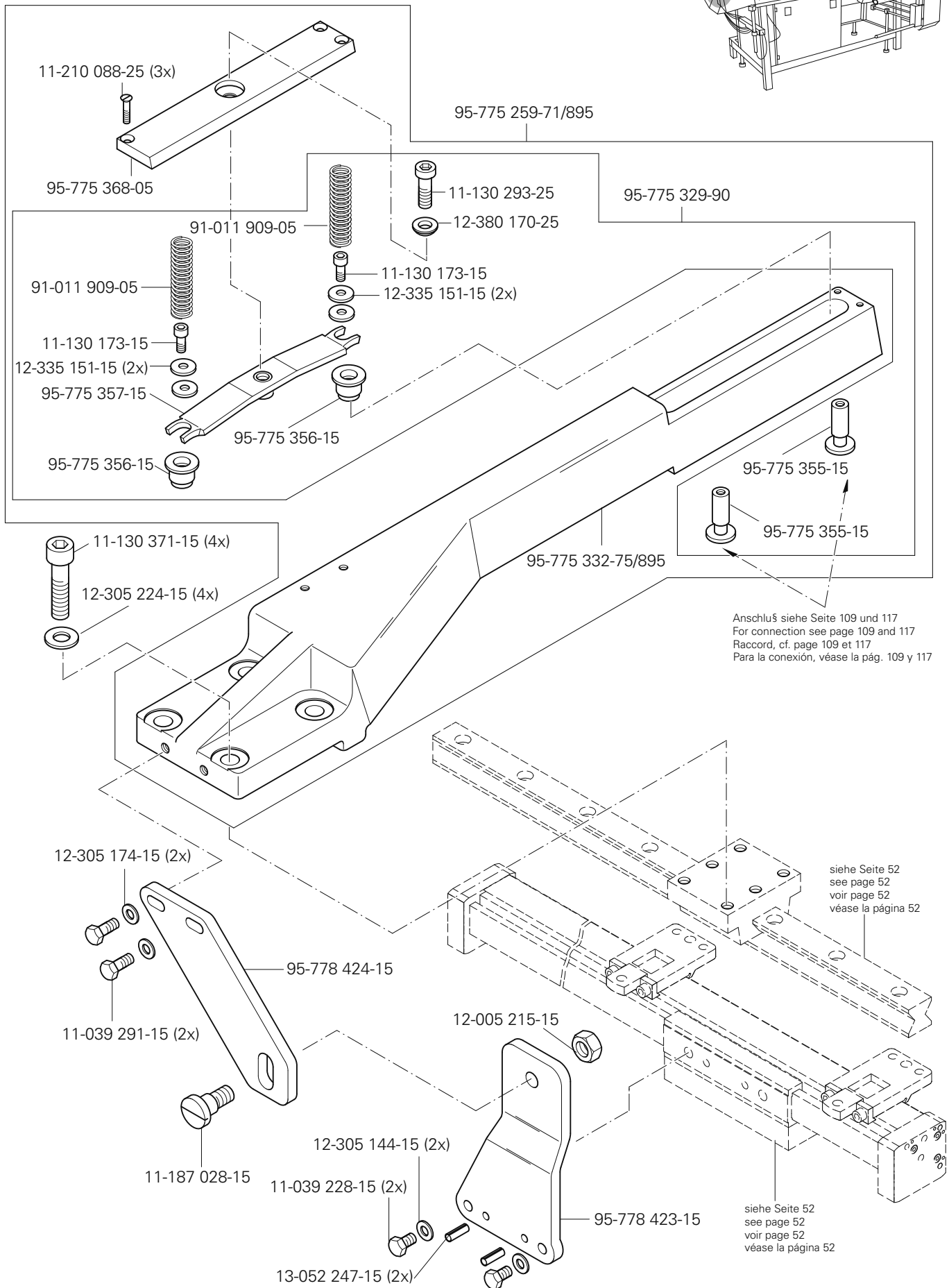
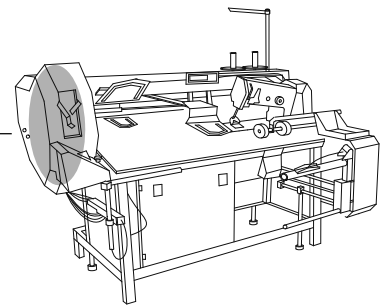

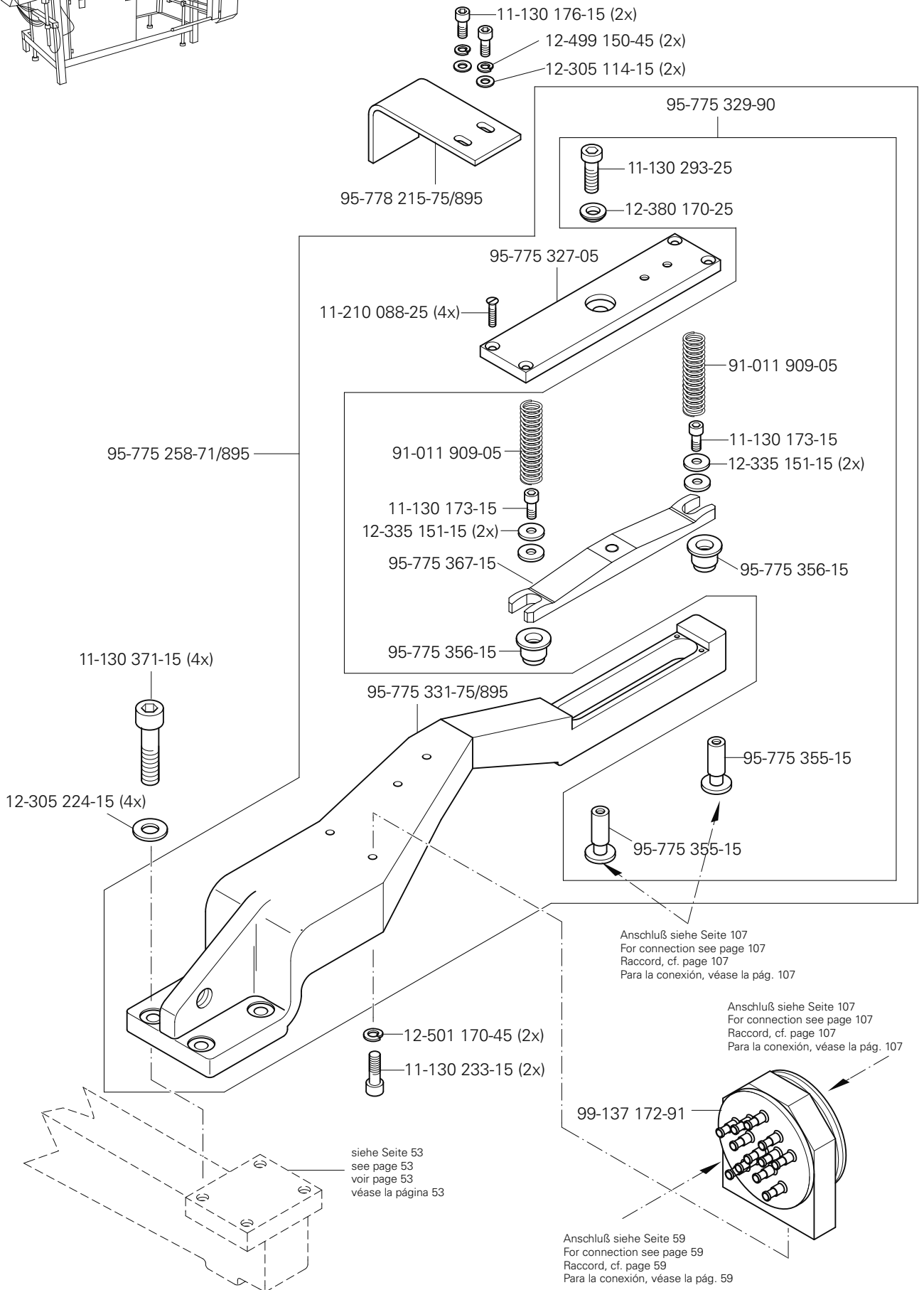
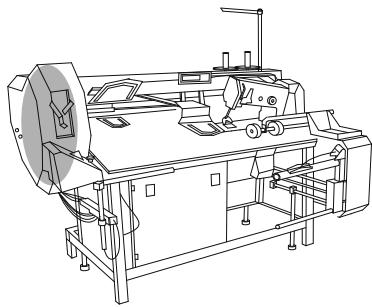

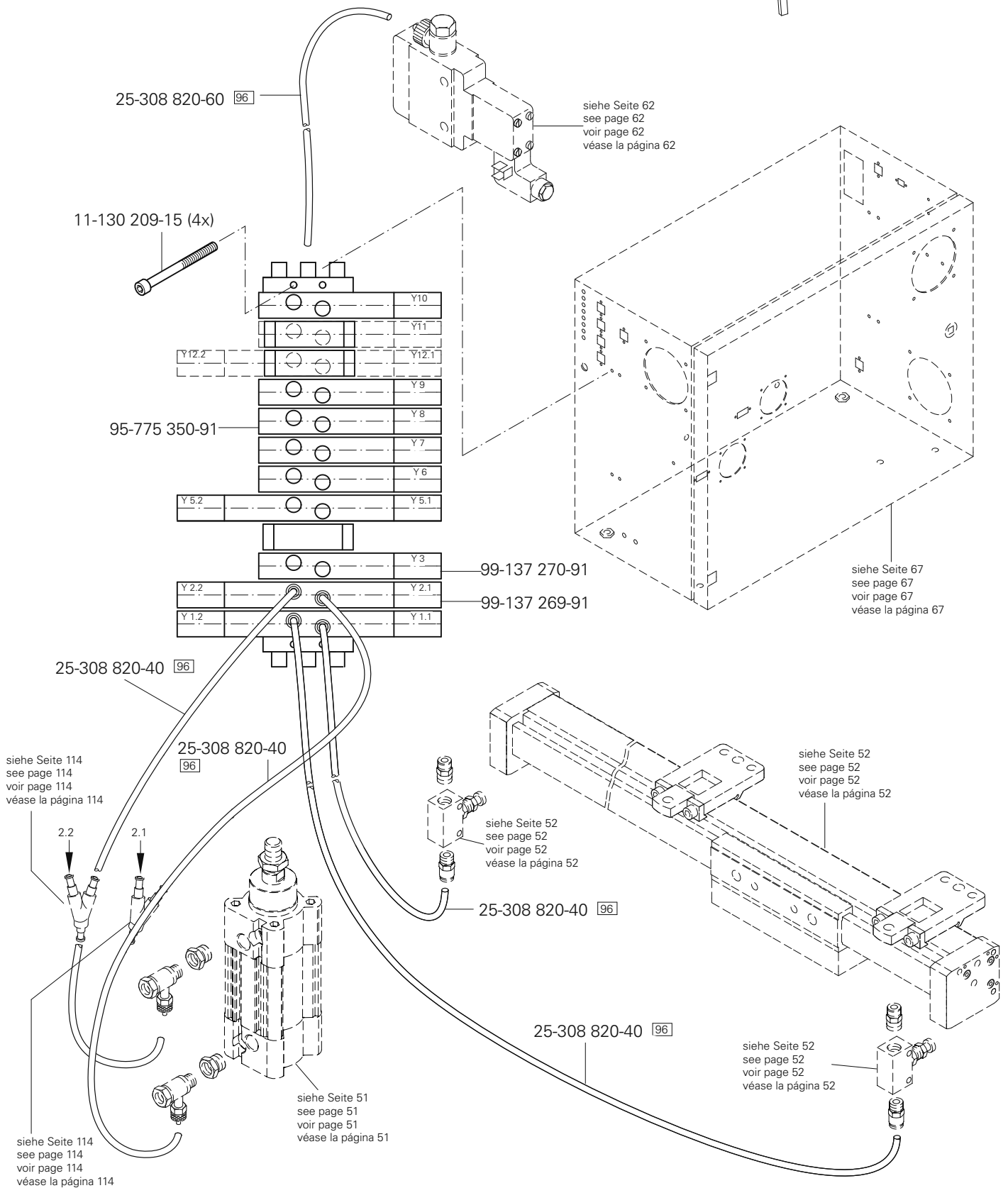
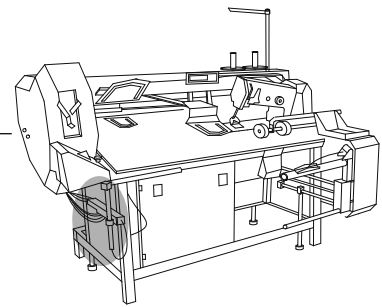

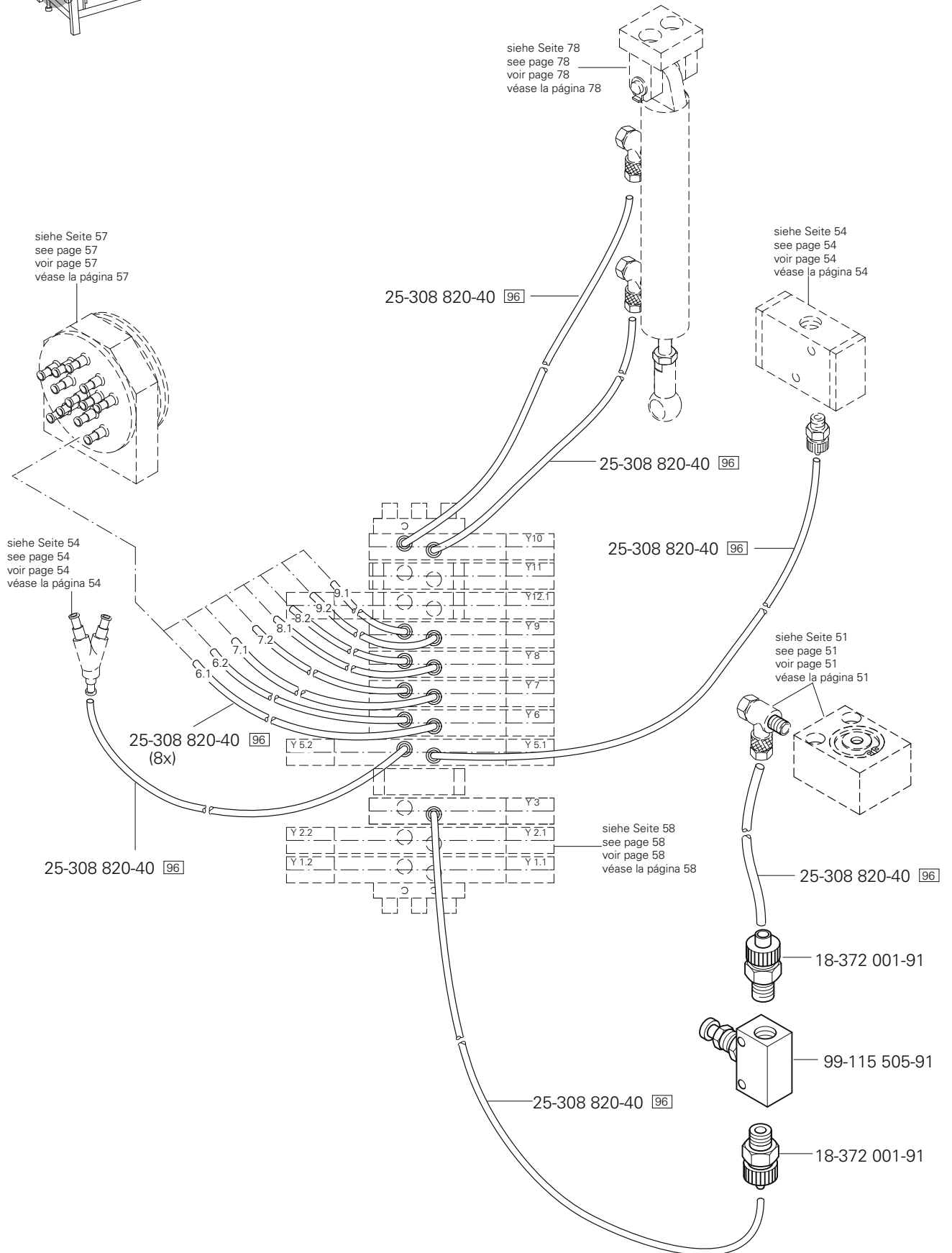
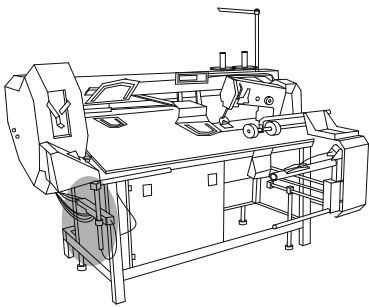

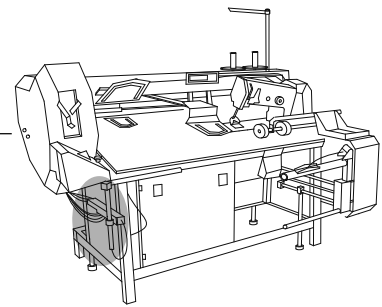

siehe Seite 34
 see page 34
 voir page 34
 véase la página 34

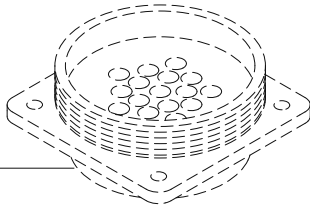

99-135 818-05

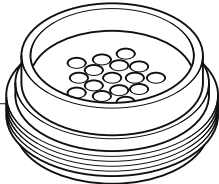

99-135 819-05

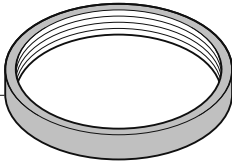

99-135 353-91 (10x)



99-135 496-95

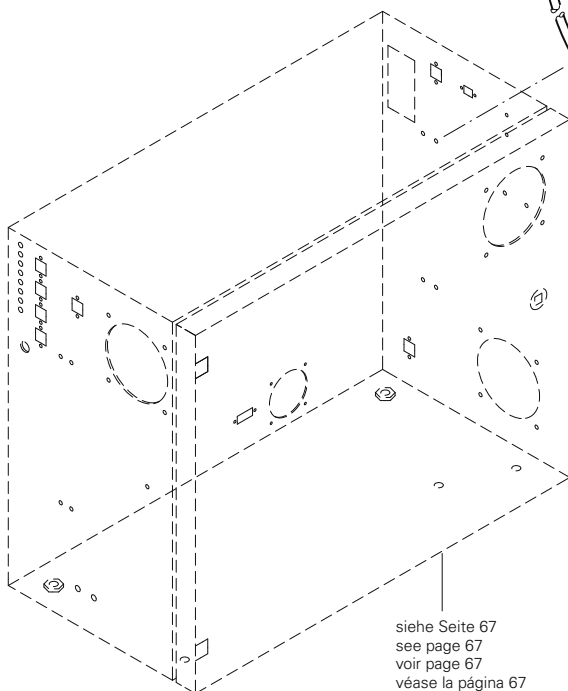

siehe Seite 67
 see page 67
 voir page 67
 véase la página 67

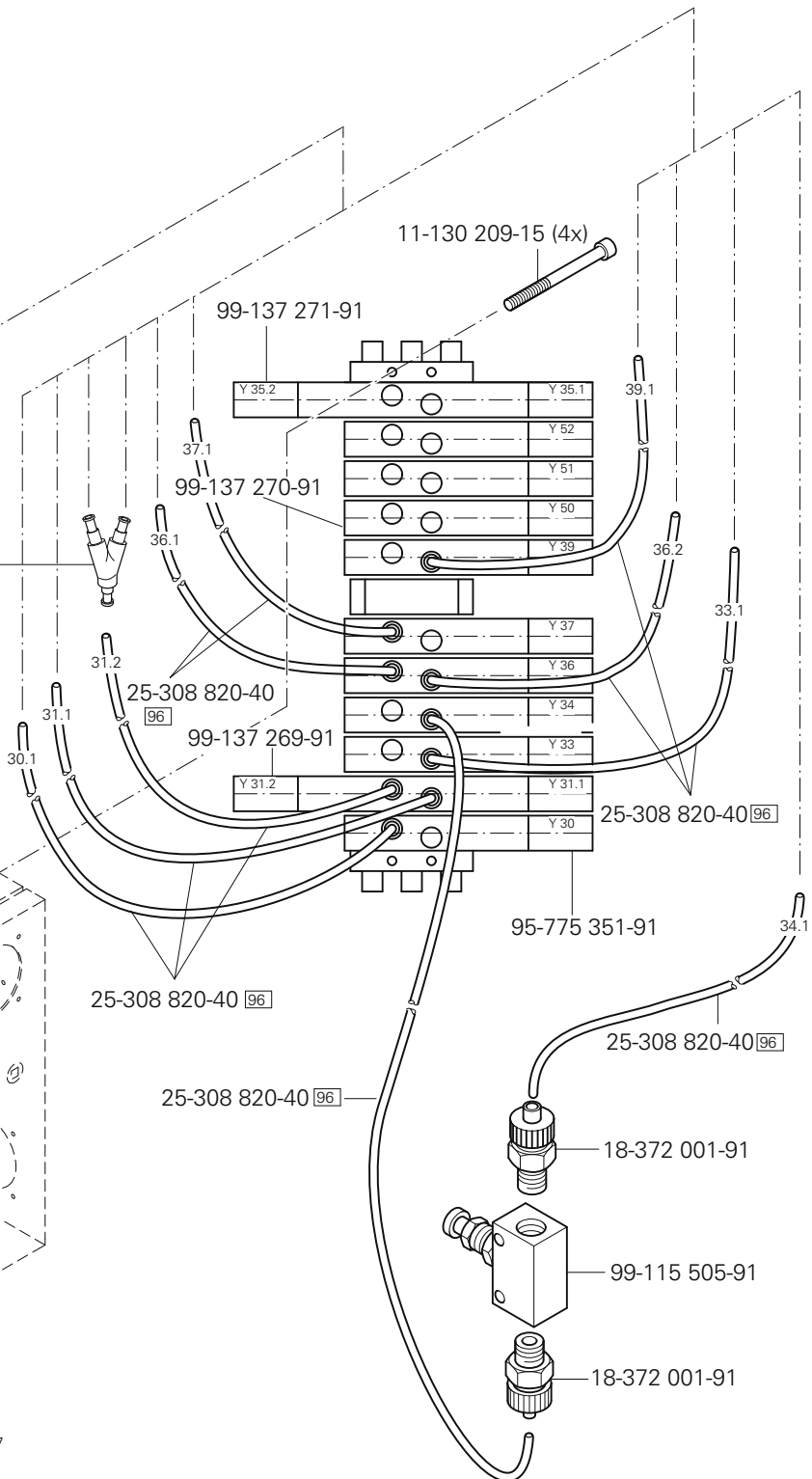

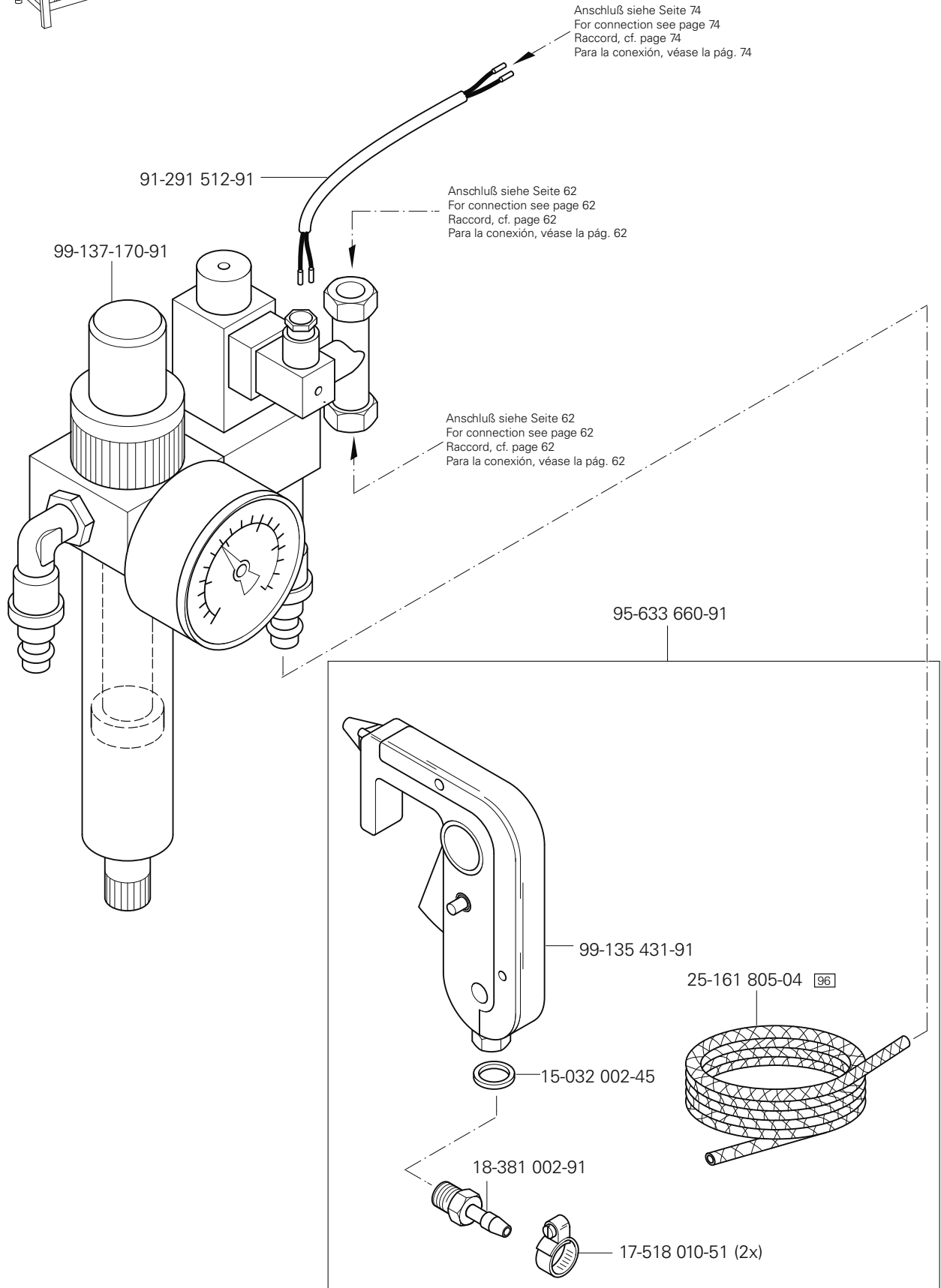
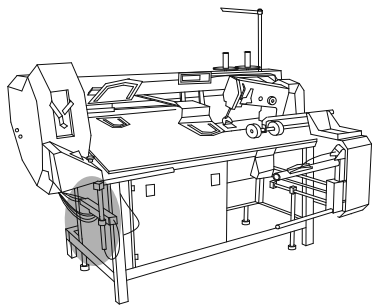

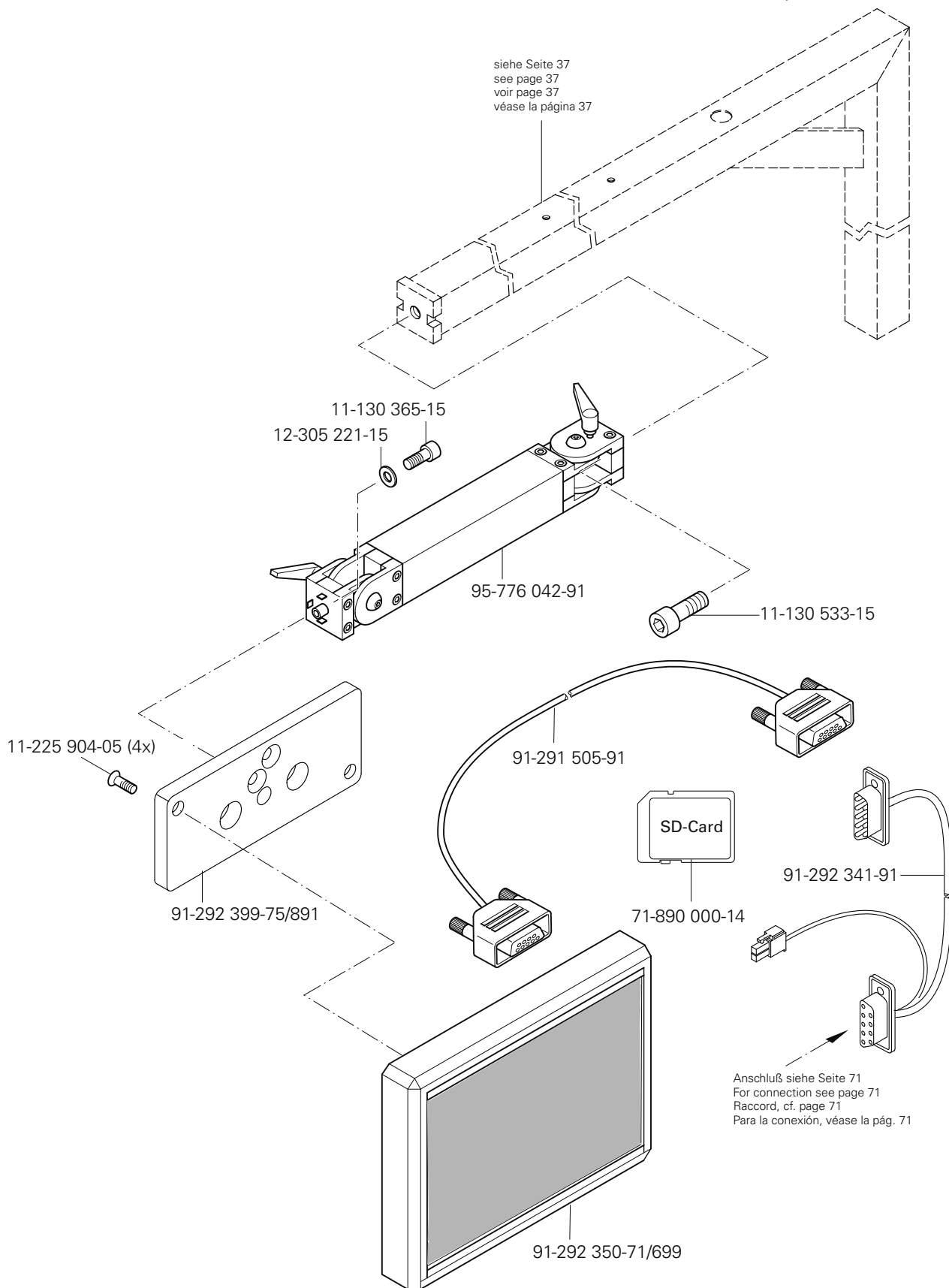
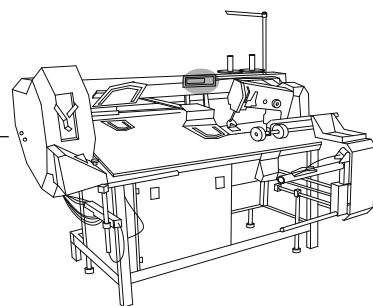

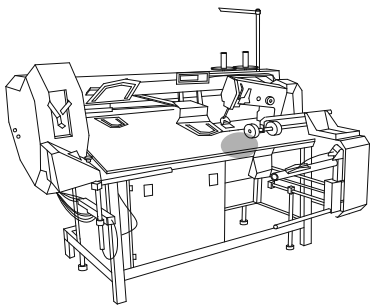

Notausschalter und Nähmotor
 Emergency shut-off and sewing motor
 Interrupteur d'arrêt d'urgence et moteur de machine à coudre
 Interruptor de emergencia y motor máquina de coser PFAFF 3588-05/020

10.02

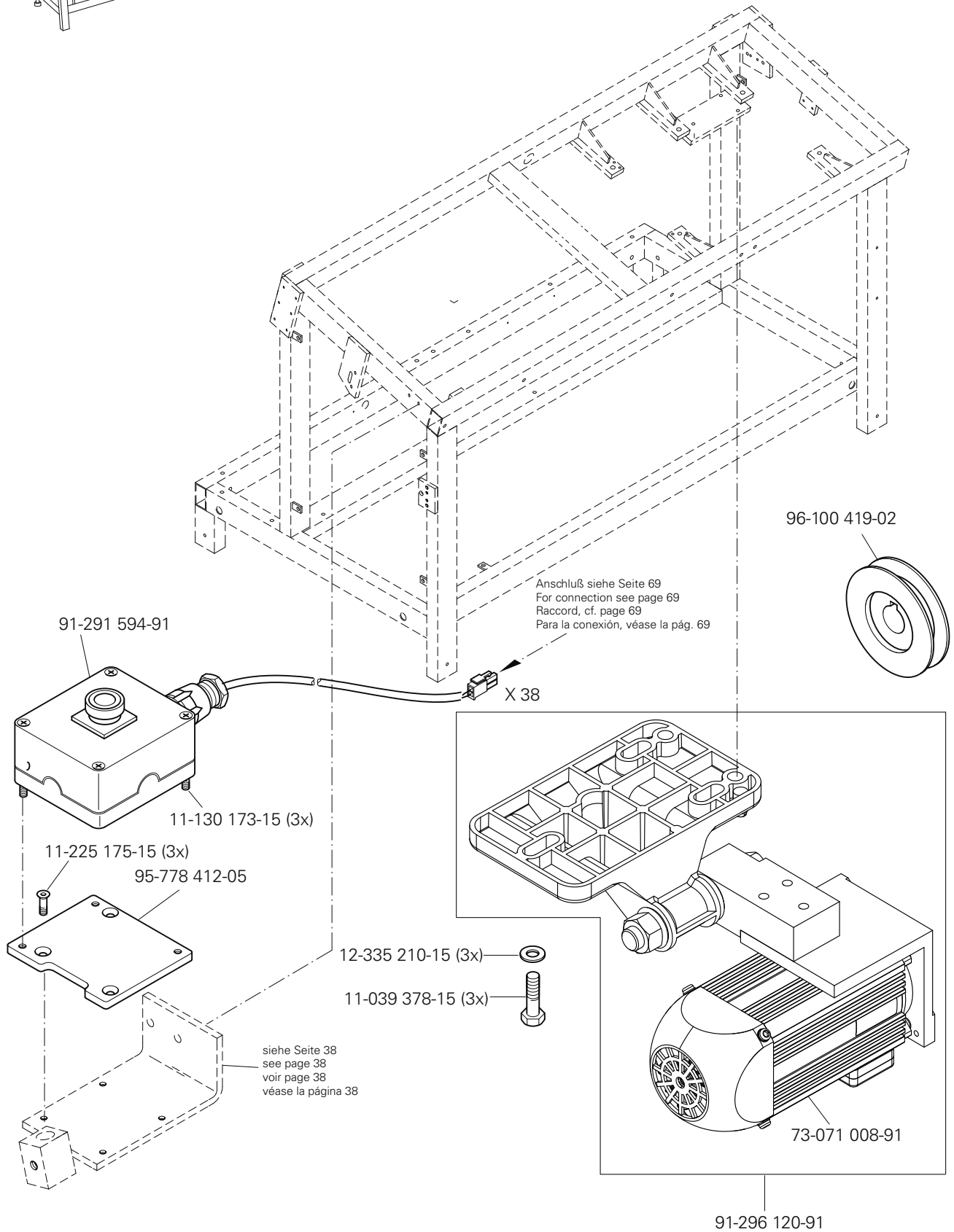

10.03

Zweihandbedienung
 Operation with both hands
 Commande à deux mains
 Manejo a dos manos

PFAFF 3588-05/020

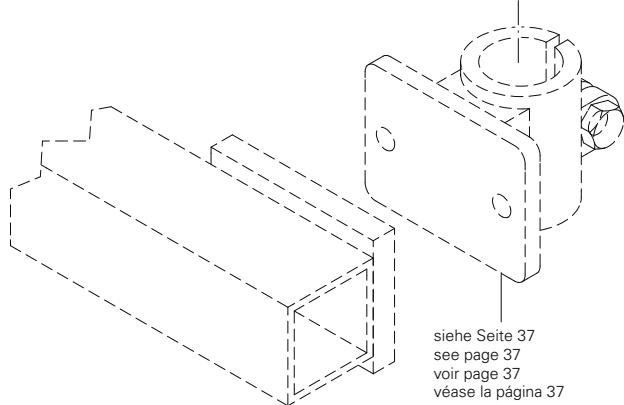
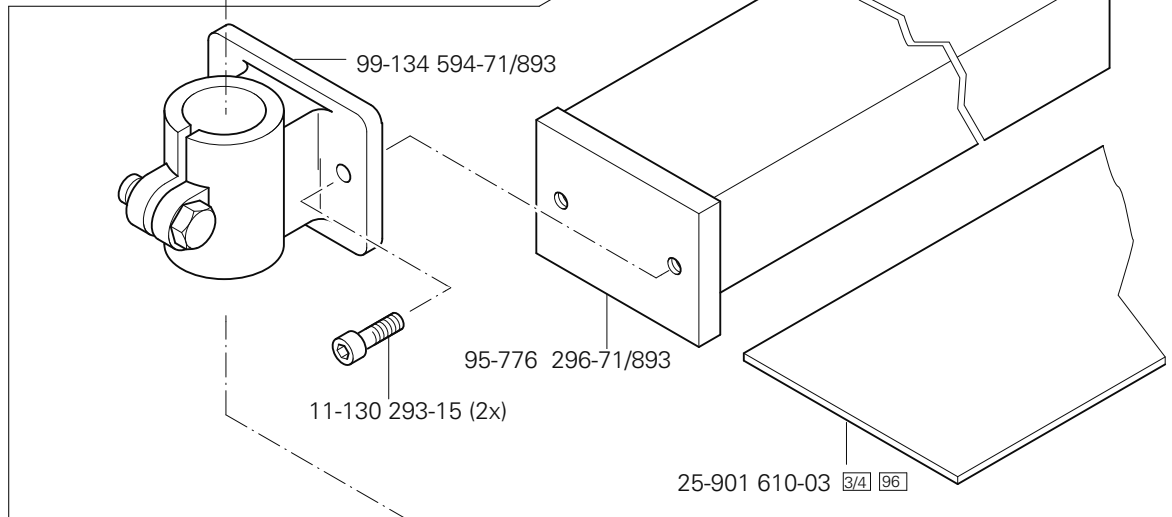
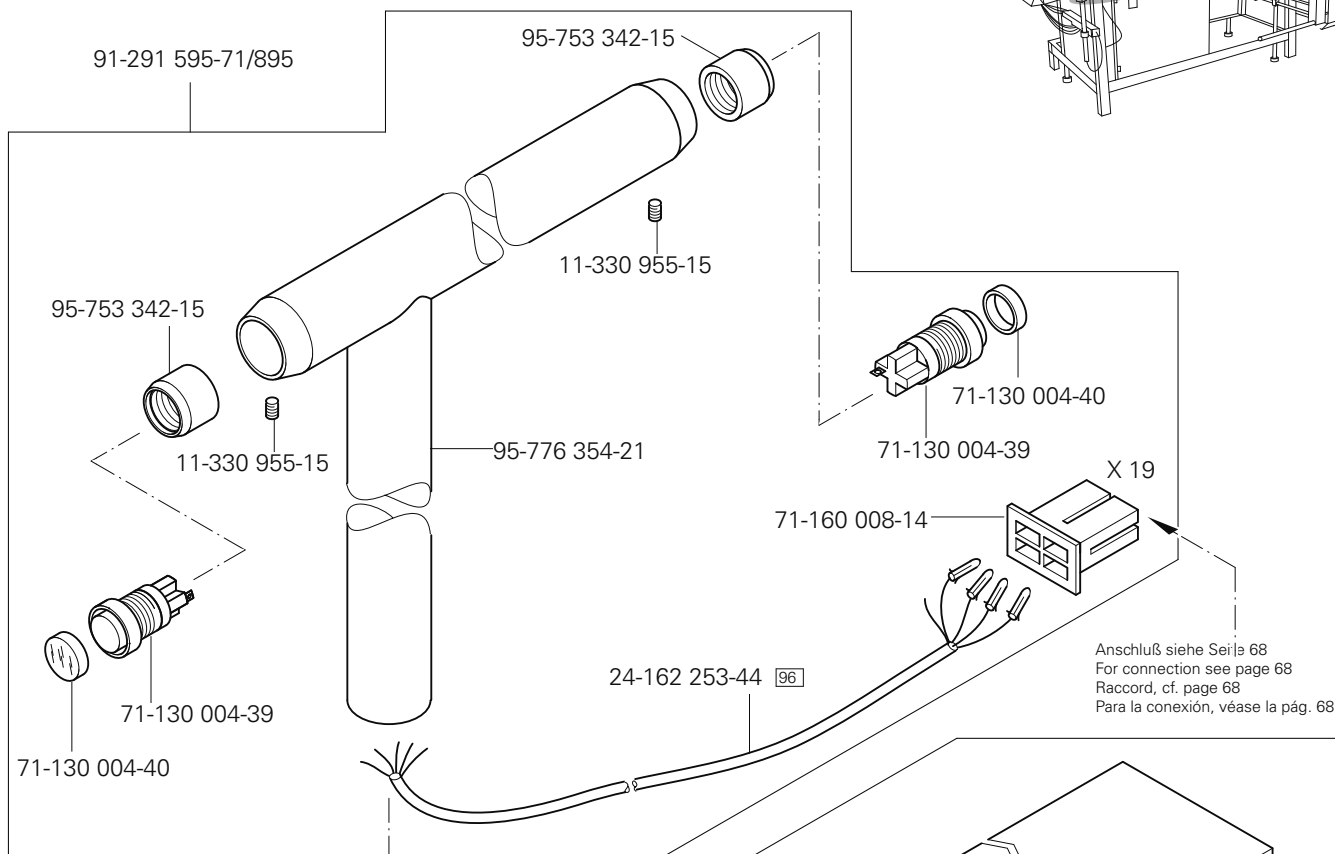
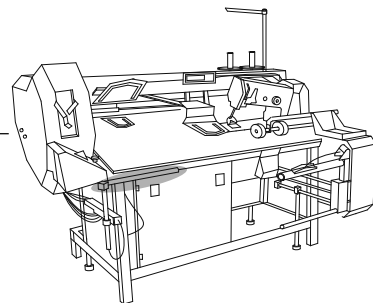

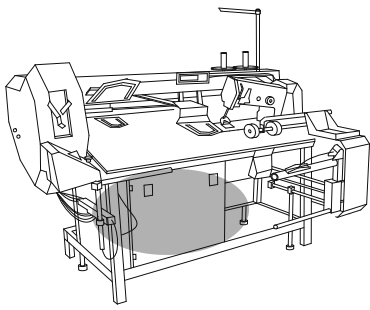

Steuergerät
Control device
Boîte de commande
Caja de mandos

PFAFF 3588-05/020

10.04

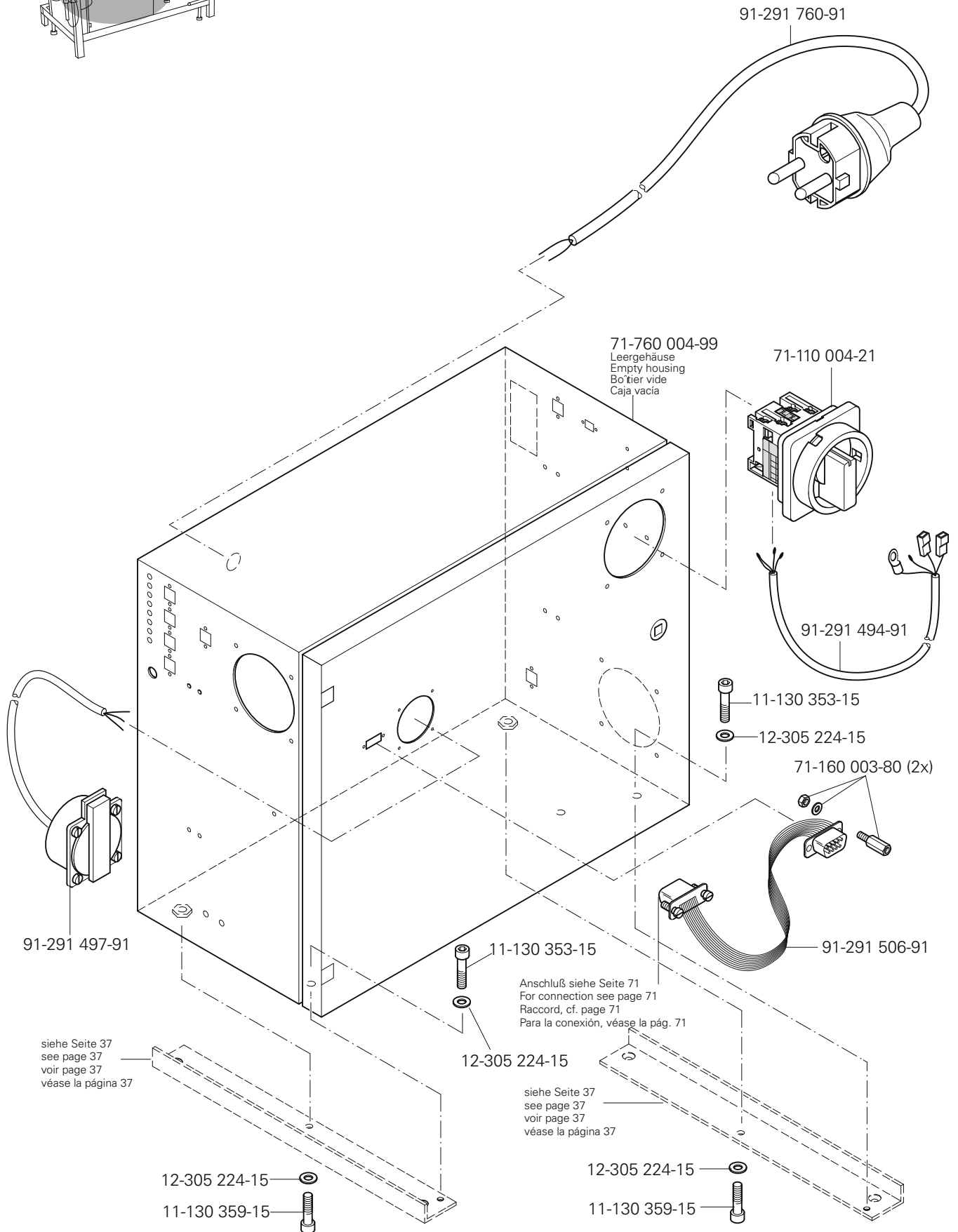

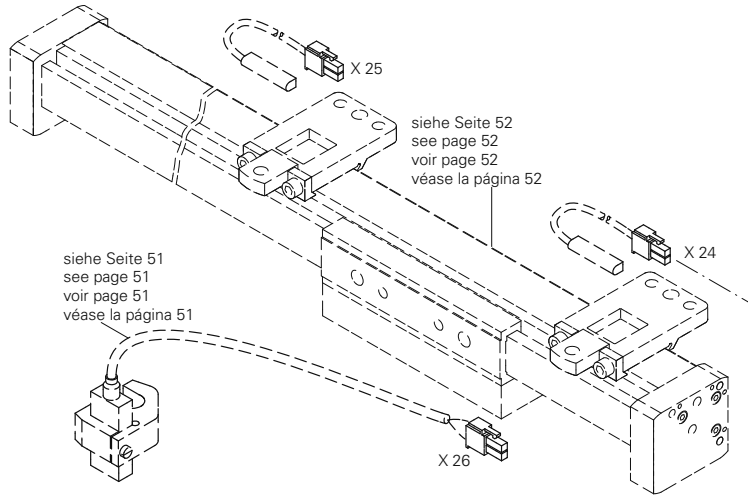
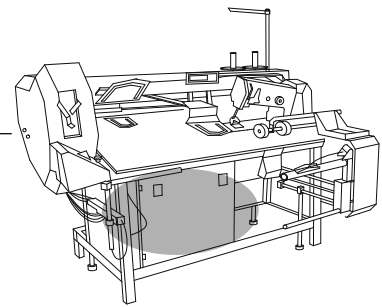

siehe Seite 51
see page 51
voir page 51
véase la página 51

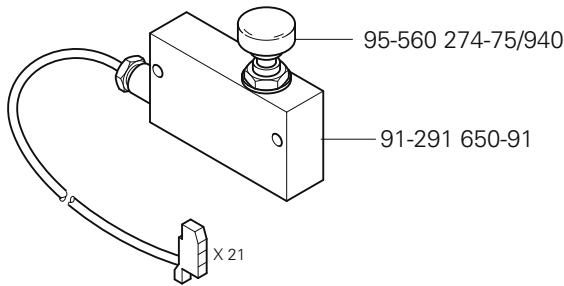
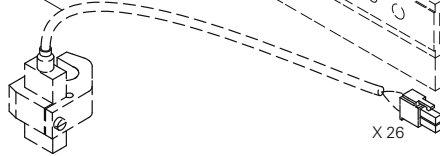

11-108 099-25 (2x)

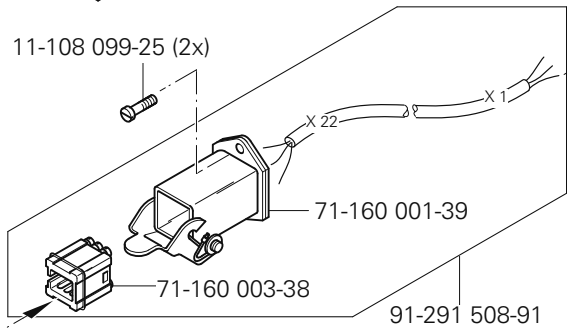

Anschluß siehe Seite 78
For connection see page 78
Raccord, cf. page 78
Para la conexión, véase la pág. 78

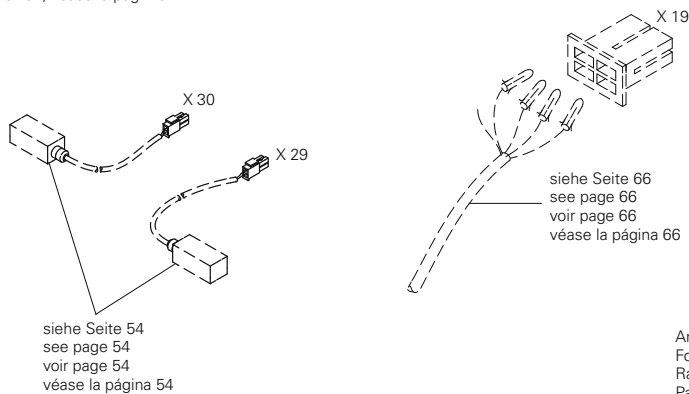

siehe Seite 54
see page 54
voir page 54
véase la página 54

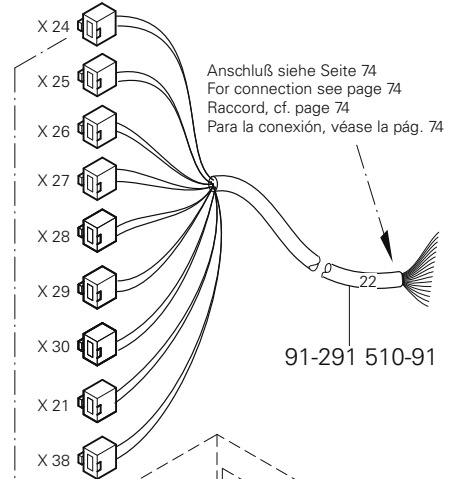

Anschluß siehe Seite 74
For connection see page 74
Raccord, cf. page 74
Para la conexión, véase la pág. 74

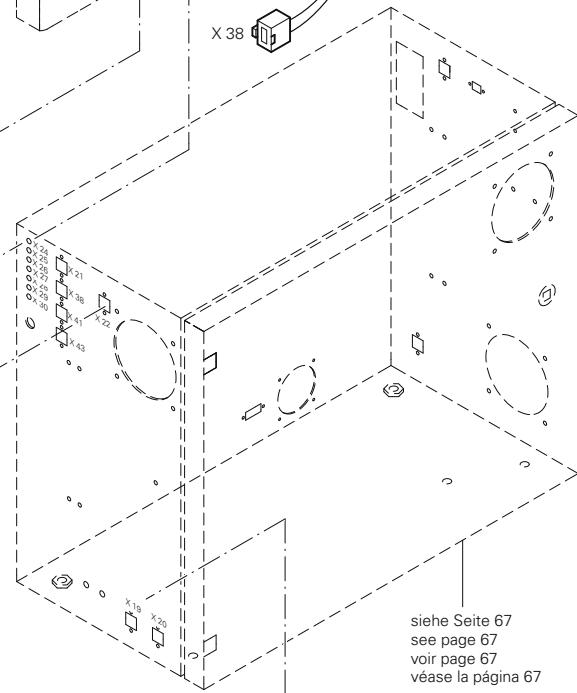

Anschluß siehe Seite 74
For connection see page 74
Raccord, cf. page 74
Para la conexión, véase la pág. 74

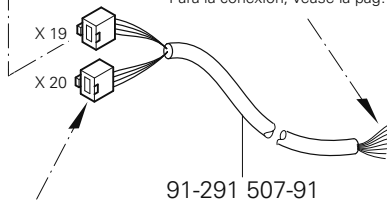

Anschluß siehe Seite 97
For connection see page 97
Raccord, cf. page 97
Para la conexión, véase la pág. 97

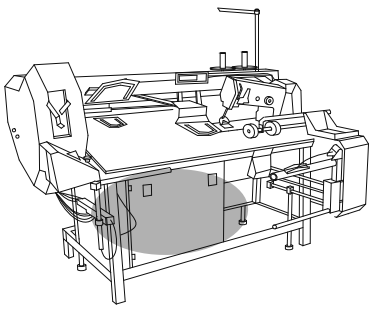

Steuergerät
Control device
Boîte de commande
Caja de mandos

PFAFF 3588-05/020

10.04

Anschluß siehe Seite 74
For connection see page 74
Raccord, cf. page 74
Para la conexión, véase la pág. 74

siehe Seite 65
see page 65
voir page 65
véase la página 65

Anschluß siehe Seite 74
For connection see page 74
Raccord, cf. page 74
Para la conexión, véase la pág. 74

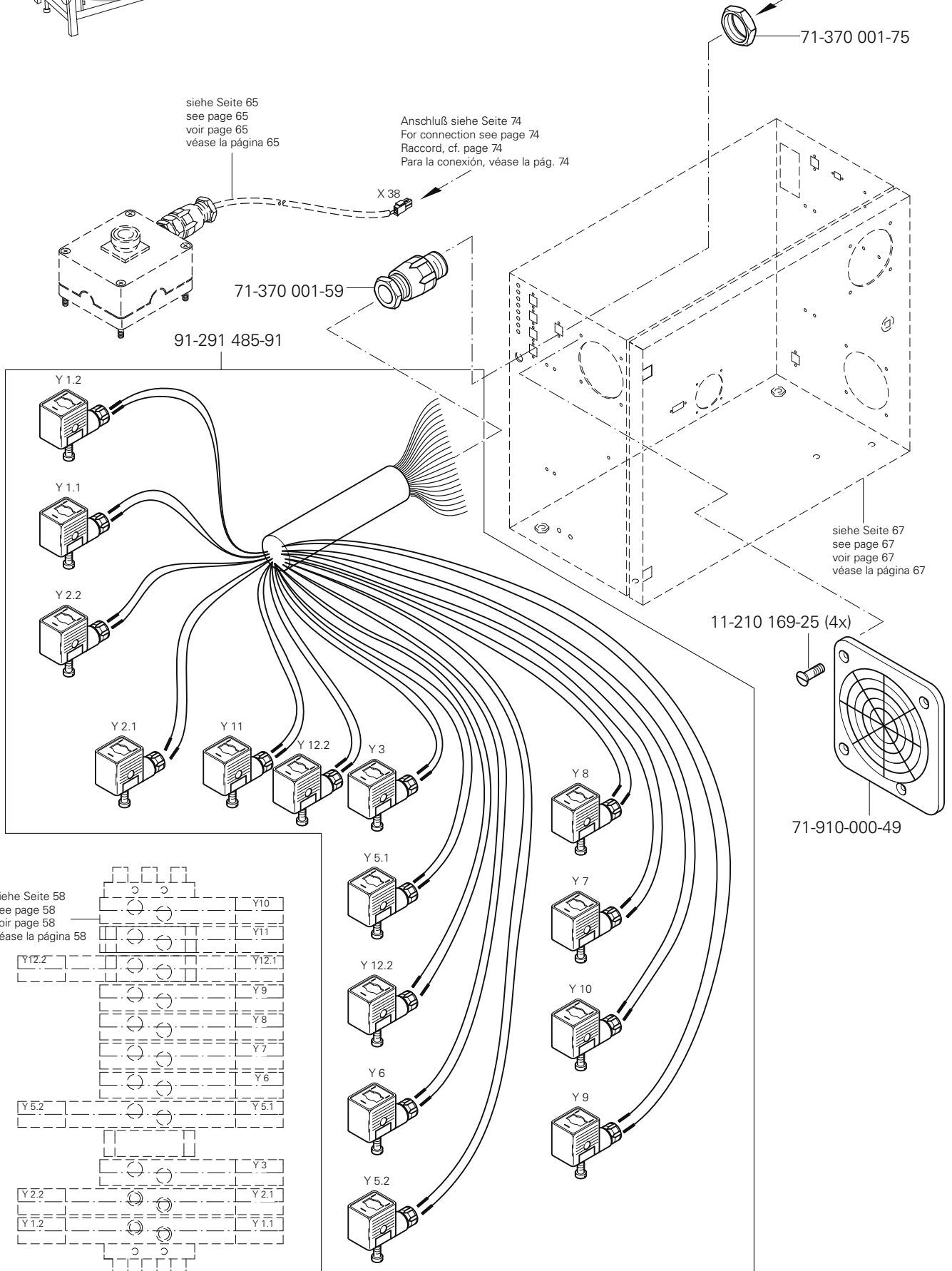

siehe Seite 58
see page 58
voir page 58
véase la página 58

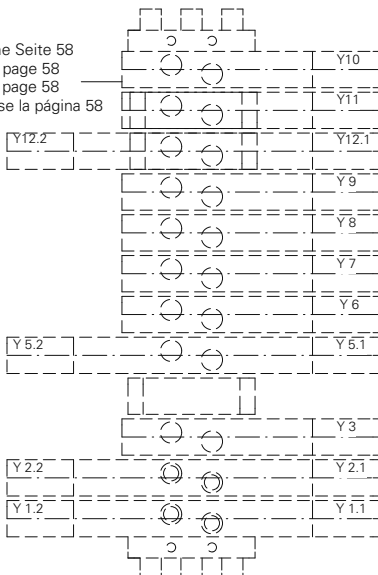

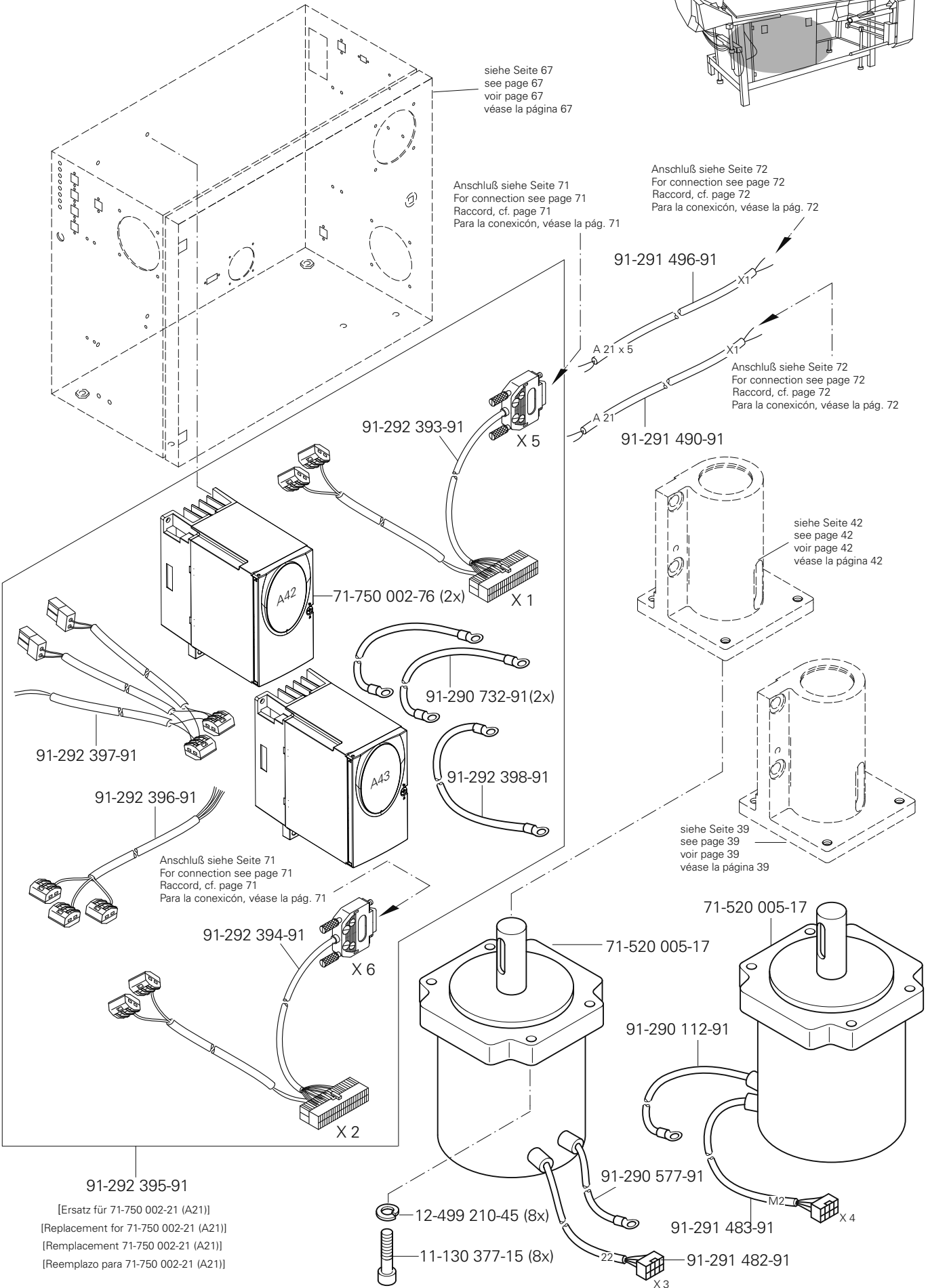
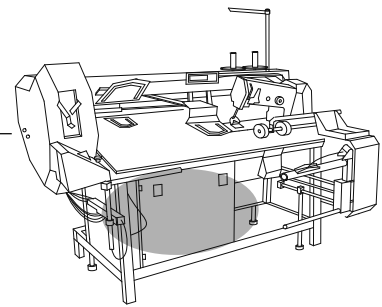

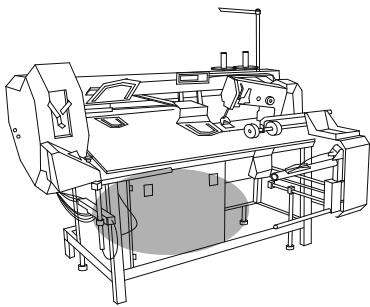

Steuergerät
Control device
Boîte de commande
Caja de mandos

PFAFF 3588-05/020

10.04

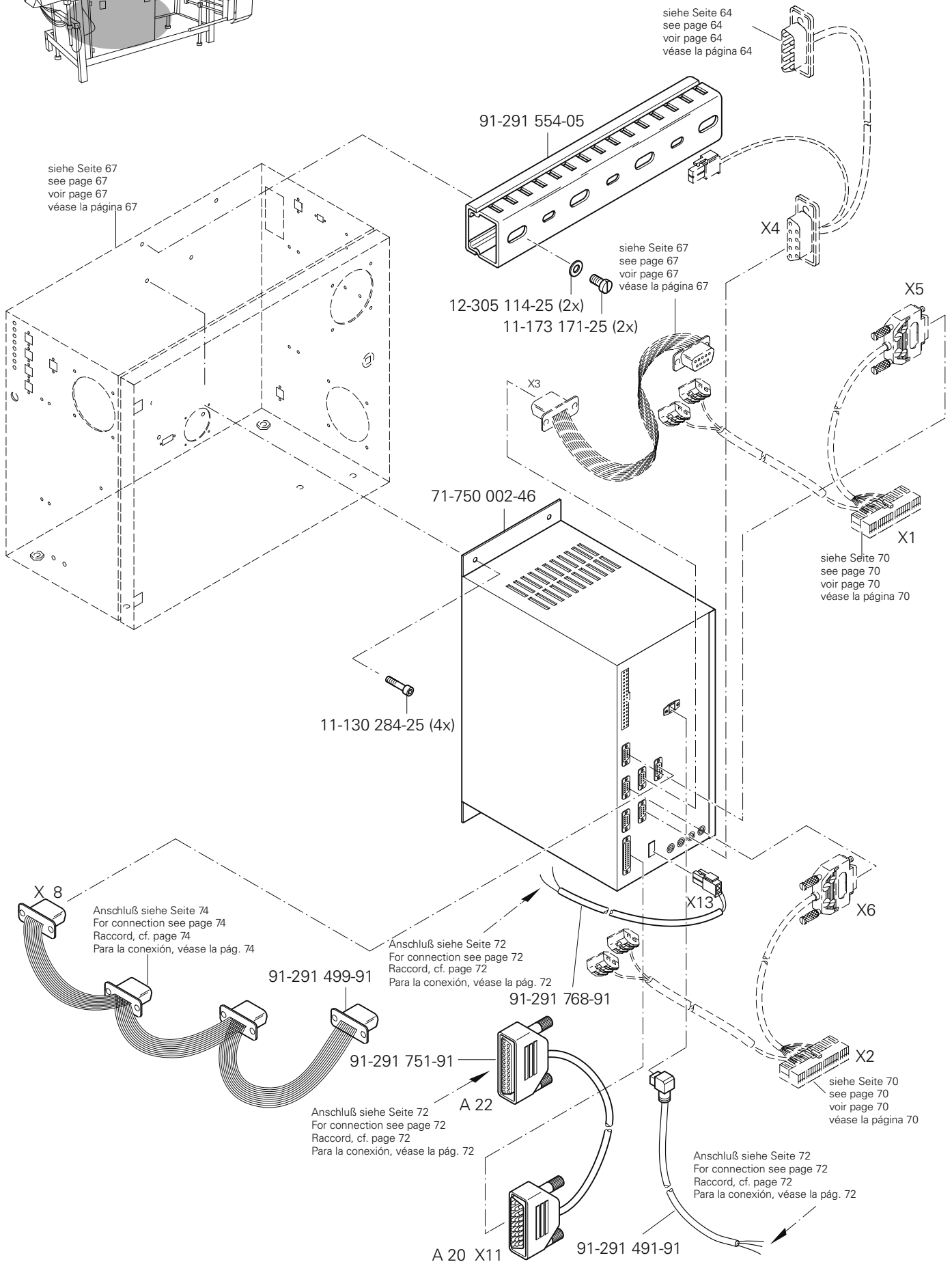

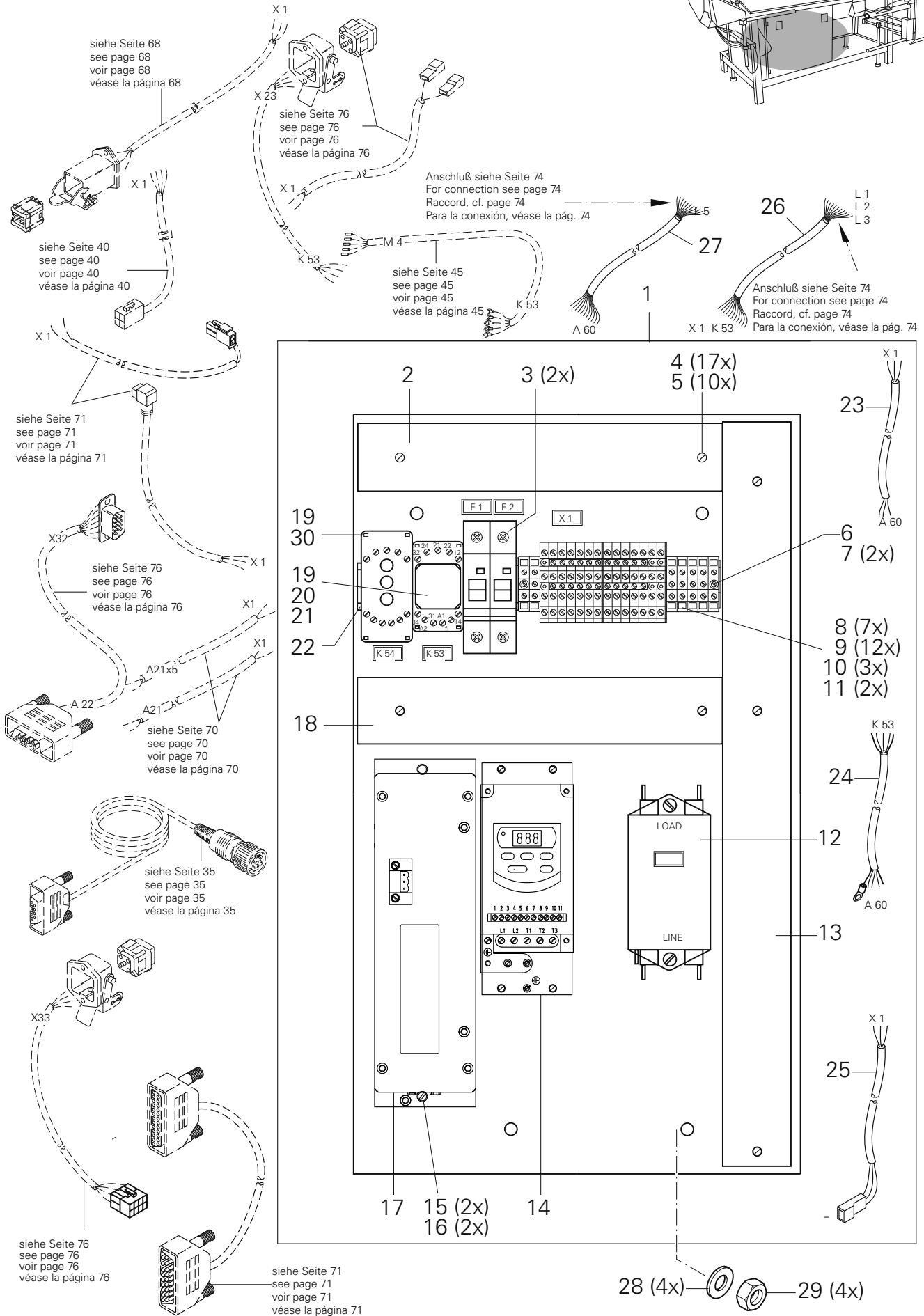
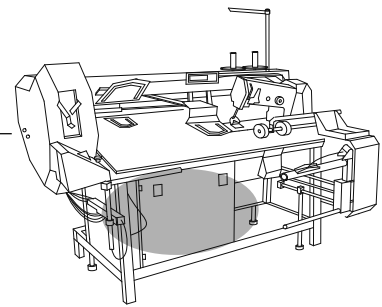

Pos.-Nr. Item No. N° pos. N° de pos.	Bestellnummer Part number N° de commande N° de pedido	Teile-Benennung Description Désignation Denominación	Pos.-Nr. Item No. N° pos. N° de pos.	Bestellnummer Part number N° de commande N° de pedido	Teile-Benennung Description Désignation Denominación
1	91-291 515-91	Montageplatte Mounting plate Plaque de montage Placa de montaje	16	12-512 170-05	Scheibe A6,4 Washer Rondelle Arandela
2	91-291 517-05	Kabelkanal Cable channel Canal de câbles Canal para cables	17	73-061 015-91	Steuergerät MMC 1002 Control unit Appareil de commande Aparato de mando
3	71-150 000-69	Sicherungsautomat 1 pol. 16 A Overload cutout, 1-pole Couple-circuit 1 pôle Fusible automático 1 polo	18	91-291 550-05	Kabelkanal Cable channel Canal de câbles Canal para cables
4	11-173 171-25	Flachkopfschraube M4 x 6 Countersunk head screw Vis à tête plate Tornillo de cabeza plana	19	71-190 001-18	Relaisfassung Relay holder Douille du relais Portarelés
5	12-512 111-25	Scheibe A4,3 Washer Rondelle Arandela	20	71-190 002-13	Haltebügel Retainer Etrier de maintien Estribo de sujecion
6	91-291 674-45	Tragschiene Support rail Réglette de bornes Regleta portabornes	21	71-190 000-60	Relais 24V Relay Relais Relé
7	11-210 165-15	Senkschraube M4 x 6 Countersunk screw Vis à tête noyée Tornillo avellanado	22	91-291 516-05	Trageschiene Support rail Réglette de bornes Regleta portabornes
8	71-210 002-21	Schutzleiterklemme Ground wire terminal Borne de terre Borne de puesta a tierra	23	91-291 511-91	Leitung Tube Tuyau Tubo
9	71-210 002-52	Anreihklemme Terminal strip Borne enfilable Borne	24	91-291 489-91	Leitung Tube Tuyau Tubo
10	71-210 002-50	Abschlußplatte Cover Plaque de fermeture Tapa	25	91-291 492-91	Leitung Tube Tuyau Tubo
11	71-210 002-40	Verbindungssteg Connector Barrette de jonction Clavija de unión	26	91-291 498-91	Leitung Tube Tuyau Tubo
12	71-480 000-12	Entstörfilter Suppressor Filtre antiparasites Filtro antiparásito	27	91-291 487-91	Leitung Tube Tuyau Tubo
13	91-291 549-05	Kabelkanal Cable channel Canal de câbles Canal para cables	28	12-512 220-05	Scheibe A8,4 Washer Rondelle Arandela
14	71-750 002-96	Frequenzumrichter Frequency converter Changeur de fréquence Convertidor de frecuencias	29	12-005 215-15	Sechskantmutter M8 Hexagon nut Ecrou à six pans Tuerca hexagonal
15	11-130 299-25	Zylinderschraube M6 x 20 Pan-head screw Vis à tête cylindrique Tornillo cilíndrico	30	71-710 000-82	Grenzwertmelder Limit indicator Indicateur de valeur Indicador valor lim.



Pos.-Nr. Item No. N° pos. N° de pos.	Bestellnummer Part number N° de commande N° de pedido	Teile-Benennung Description Désignation Denominación	Pos.-Nr. Item No. N° pos. N° de pos.	Bestellnummer Part number N° de commande N° de pedido	Teile-Benennung Description Désignation Denominación
1	91-291 514-91	Montageplatte Mounting plate Plaque de montage Placa de montaje			
2	11-173 171-25	Flachkopfschraube M4 x 6 Countersunk head screw Vis à tête plate Tornillo de cabeza plana			
3	12-305 114-15	Scheibe A4,3 Washer Rondelle Arandela			
4	91-291 552-05	Kabelkanal Cable channel Canal de câbles Canal para cables			
5	91-291 551-05	Kabelkanal Cable channel Canal de câbles Canal para cables			
6	11-108 093-25	Zylinderschraube M3 x 6 Pan-head screw Vis à tête cylindrique Tornillo cilíndrico			
7	11-724 190-55	Abstandsbolzen M3 x 25 Spacing stud Boulon d'écartement Perno distaciador			
8	91-291 553-05	Kabelkanal Cable channel Canal de câbles Canal para cables			
9	91-291 362-93/001	Bestückte Leiterplatte DX 353 Solid state circuit board Carte imprimée équipée Placa de circuito impreso			
10	91-291 503-91	Leitung Tube Tuyau Tubo			
11	11-039 354-15	Sechskantschraube M8 x 12 Hexagon screw Vis à six pans Tornillo hexagonal			
12	12-005 215-15	Sechskantmutter M8 Hexagon nut Ecrou à six pans Tuerca hexagonal			



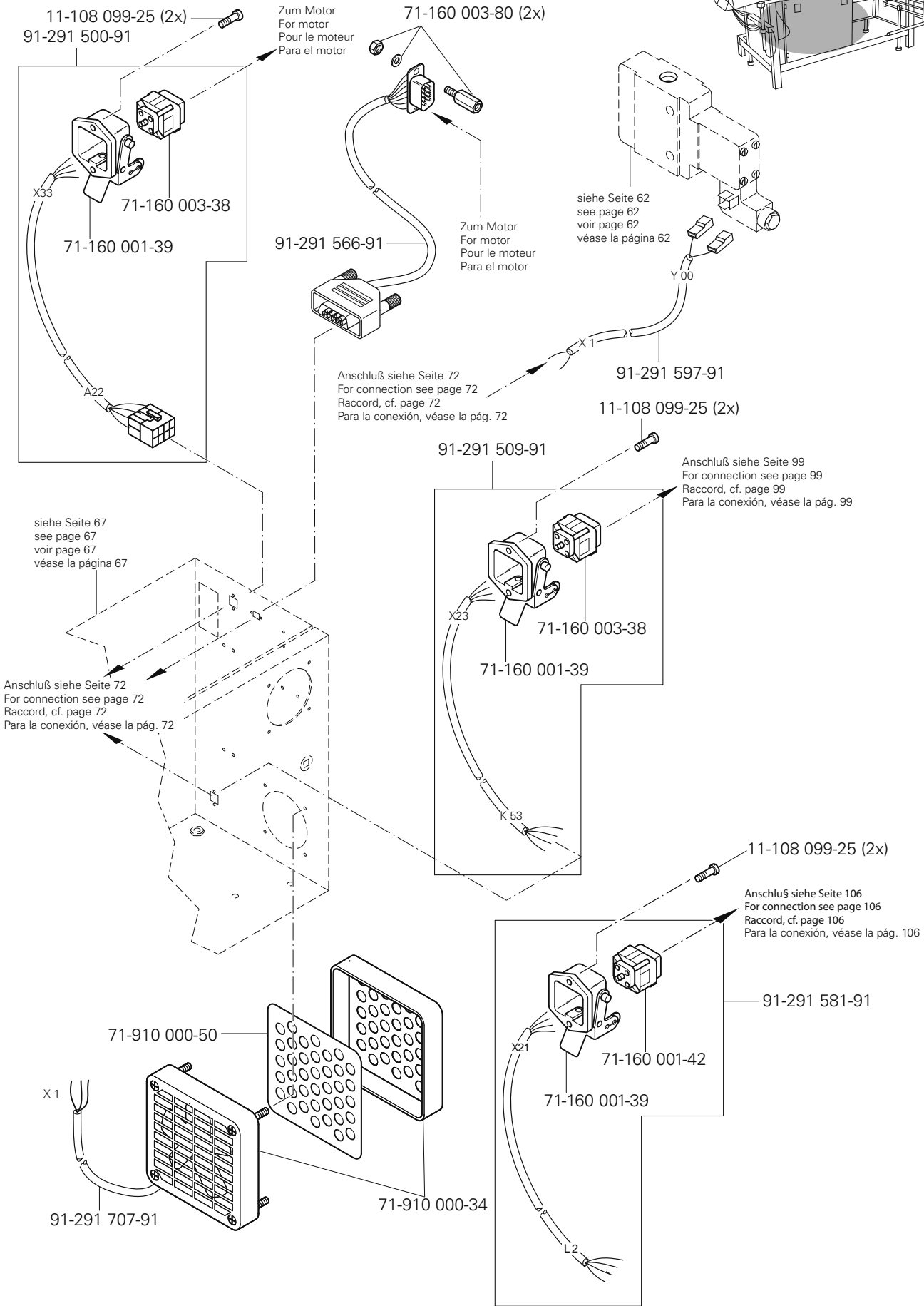
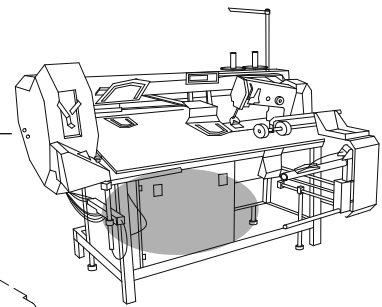

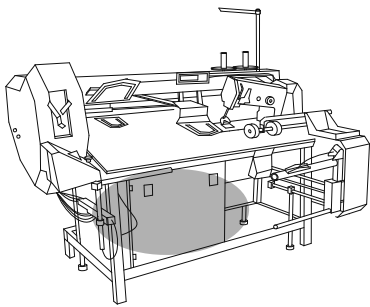

Steuergerät
Control device
Boîte de commande
Caja de mandos

PFAFF 3588-05/020

10.04

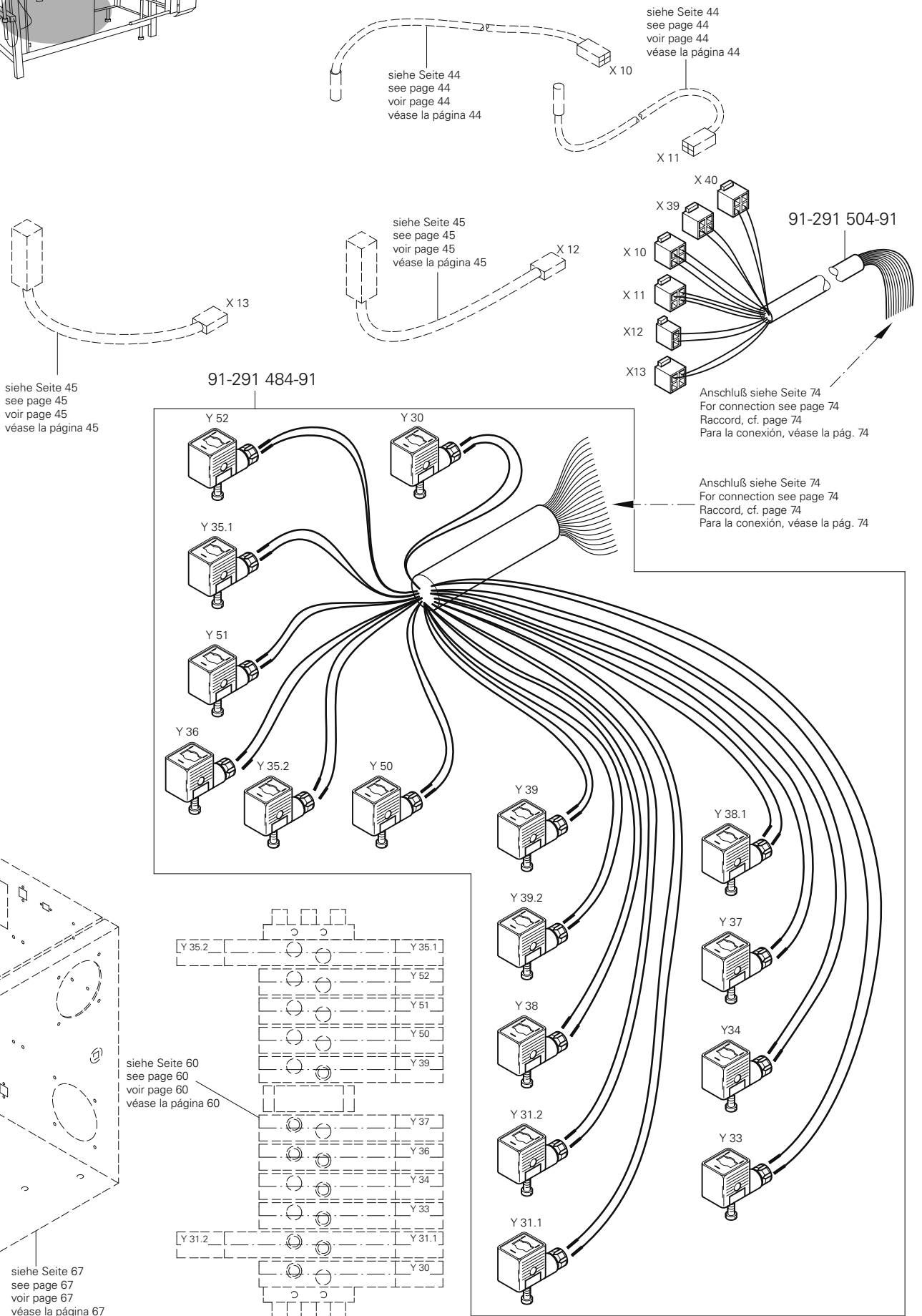

10.05

Saugeinrichtung
 Vacuum system
 Dispositif d'aspiration
 Dispositivo de aspiración

PFAFF 3588-05/020

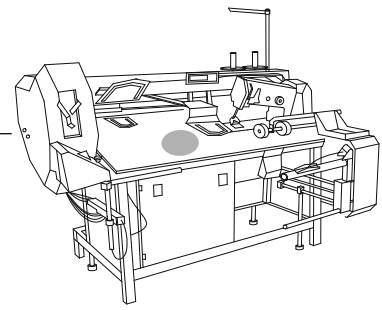

12-024 171-15 (2x)

11-130 245-15 (2x)

99-137 200-05

11-460 193-15 (4x)

71-910 000-52

11-130 245-15 (2x)

99-137 174-91

71-160 001-65

Anschluß siehe Seite 59
 For connection see page 59
 Raccord, cf. page 59
 Para la conexión, véase la pág. 59

71-370-001-59

71-160 003-37

X 22

Anschluß siehe Seite 68
 For connection see page 68
 Raccord, cf. page 68
 Para la conexión, véase la pág. 68

91-031 888-15

11-130 176-15 (2x)

12-305 114-15 (2x)

95-776 560-15

12-499 190-45

95-776 559-15

12-024 191-15

12-499 150-45 (4x)

11-130 179-15 (4x)

99-134 586-91 (2x)

11-130 233-15 (3x)

95-776 561-15 (2x)

11-130 906-15 (4x)

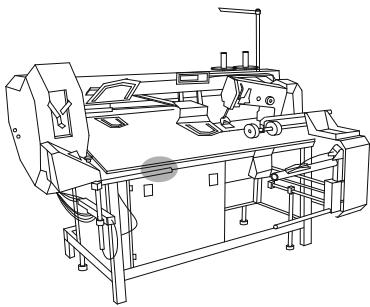

Stoffrückhaltevorrichtung
 Workpiece retainer
 Dispositif de rétension du tissu
 Dispositivo de retención del material

PFAFF 3588-05/020

10.06

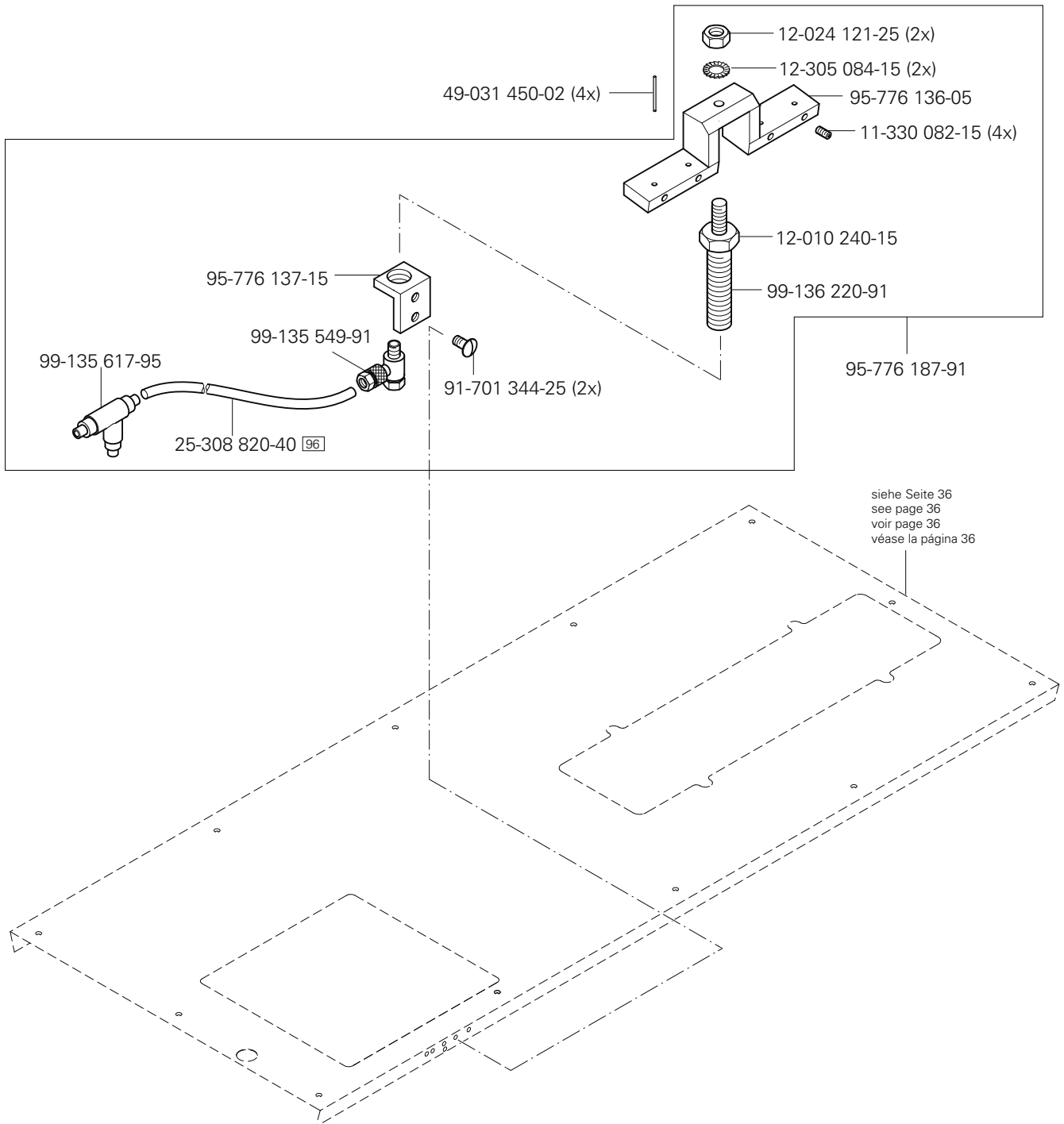

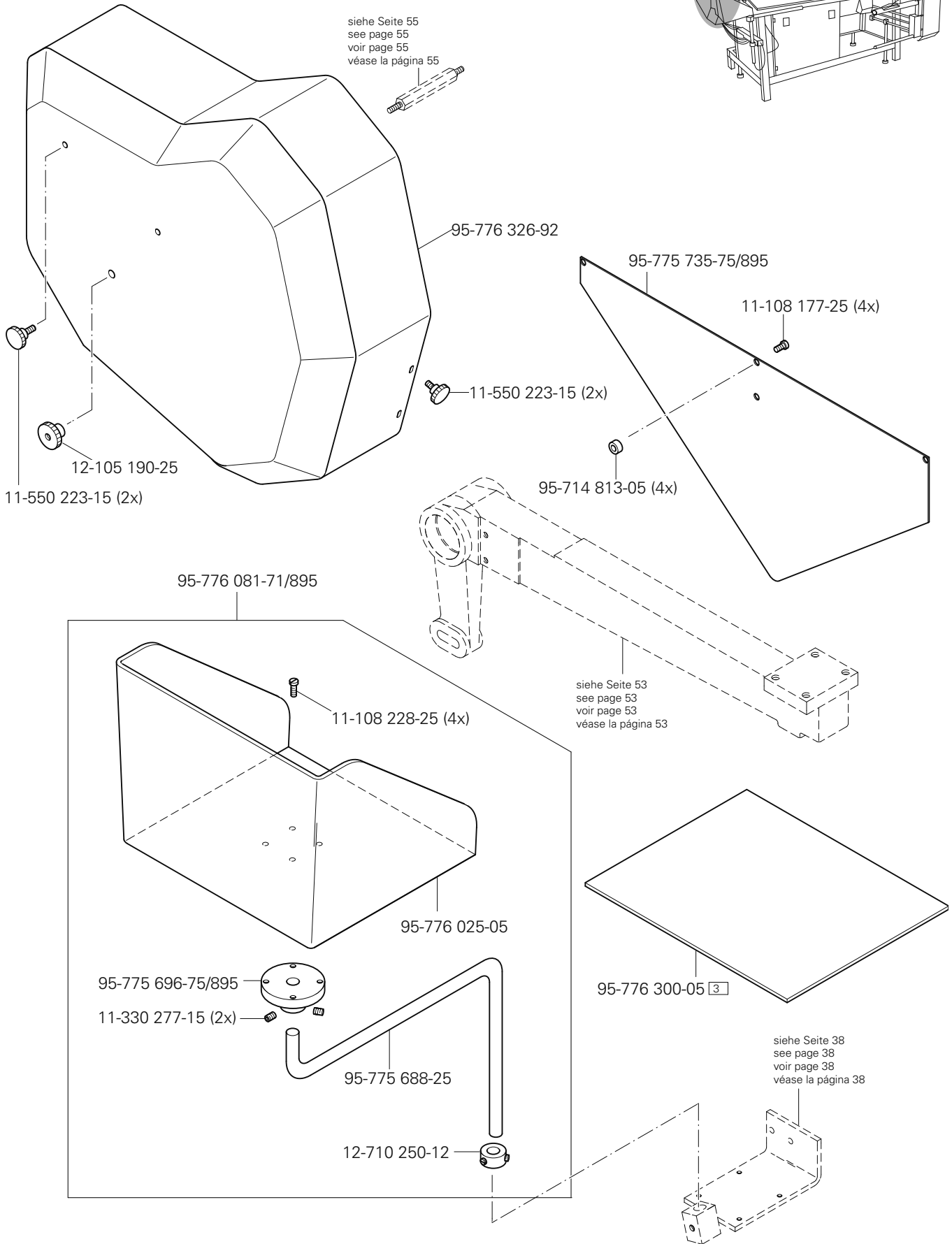
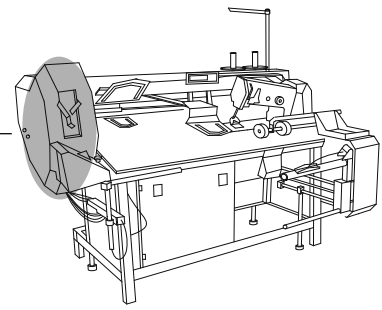

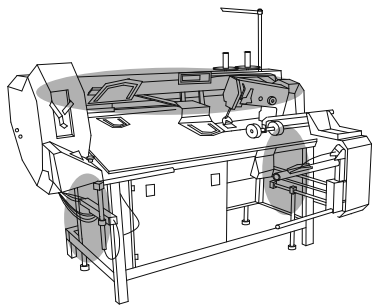

Verkleidung
Cover panel
Carters
Revestimiento

PFAFF 3588-05/020

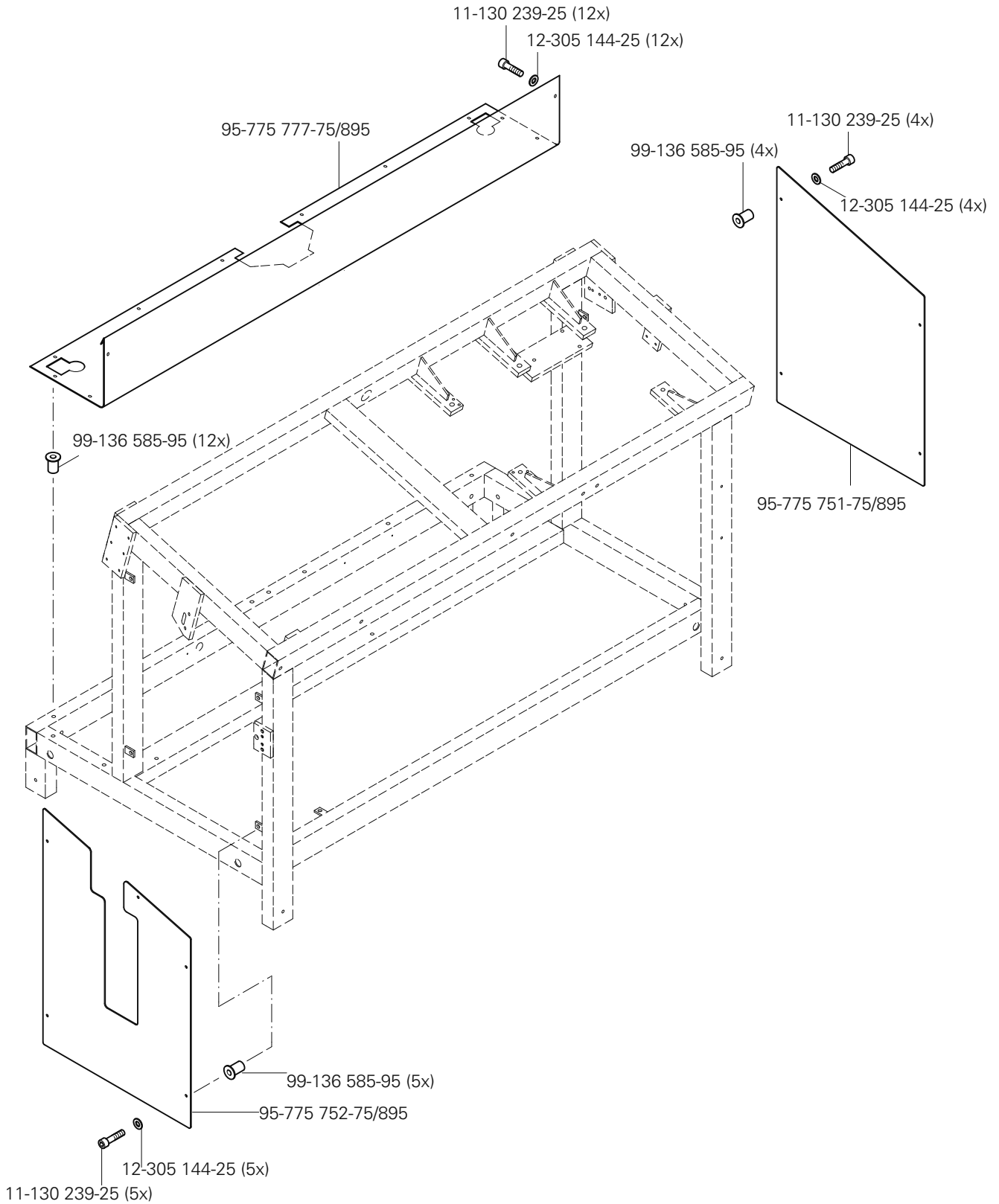

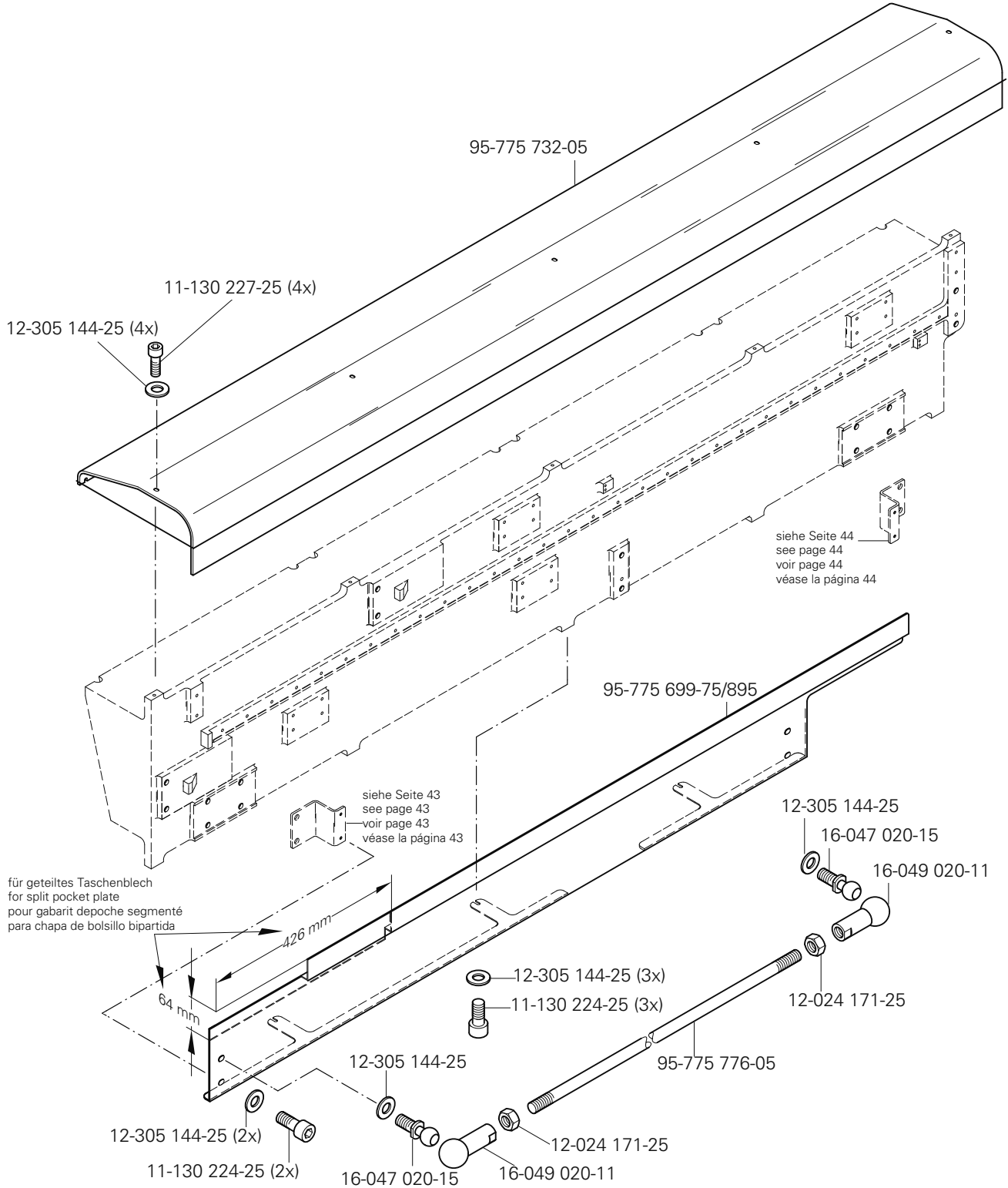
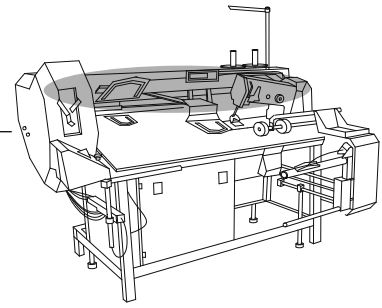

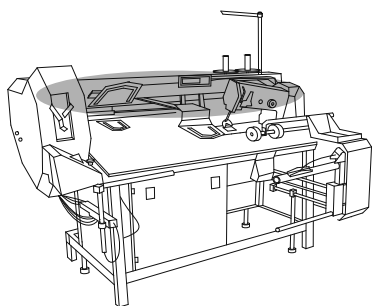

Verkleidung
Cover panel
Carters
Revestimiento

PFAFF 3588-05/020

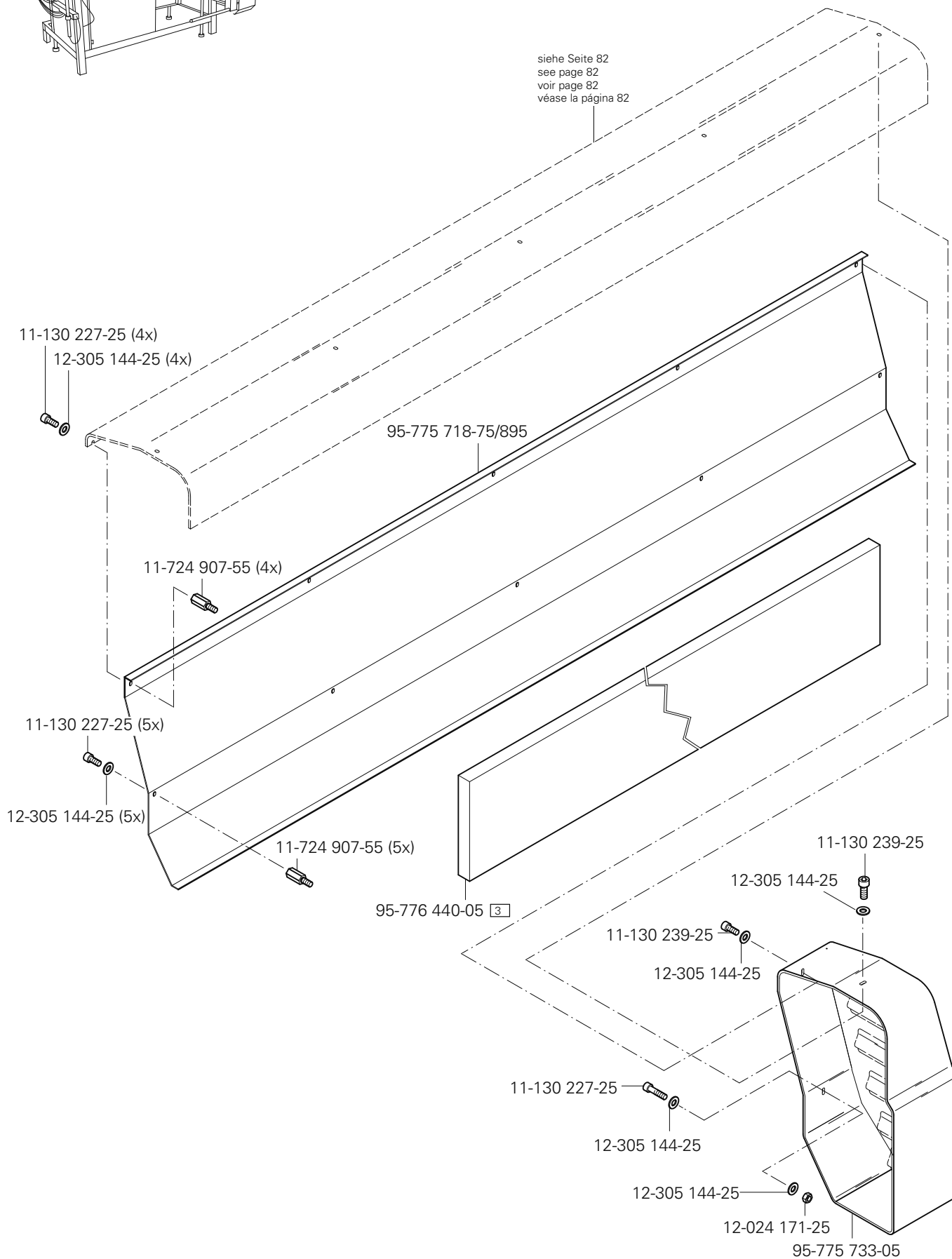

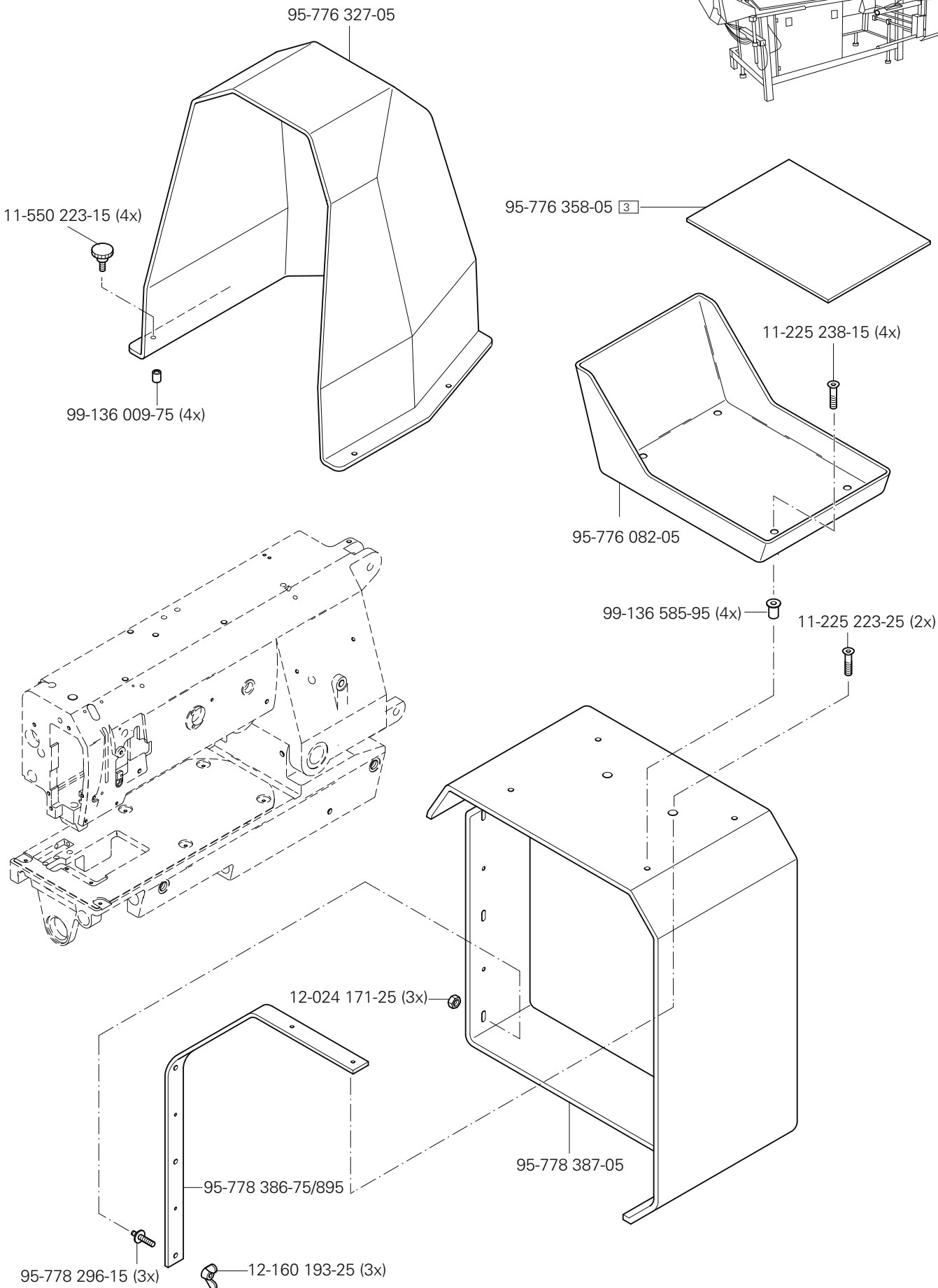
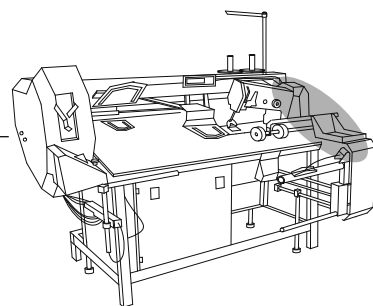

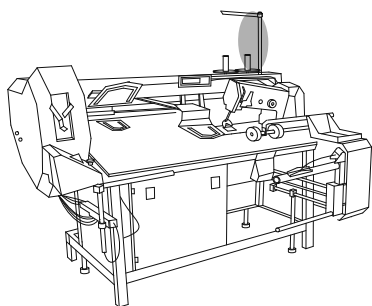

Garnrollenständer
 Reel stands
 Porte-bobines
 Portacarretes

PFAFF 3588-05/020

12

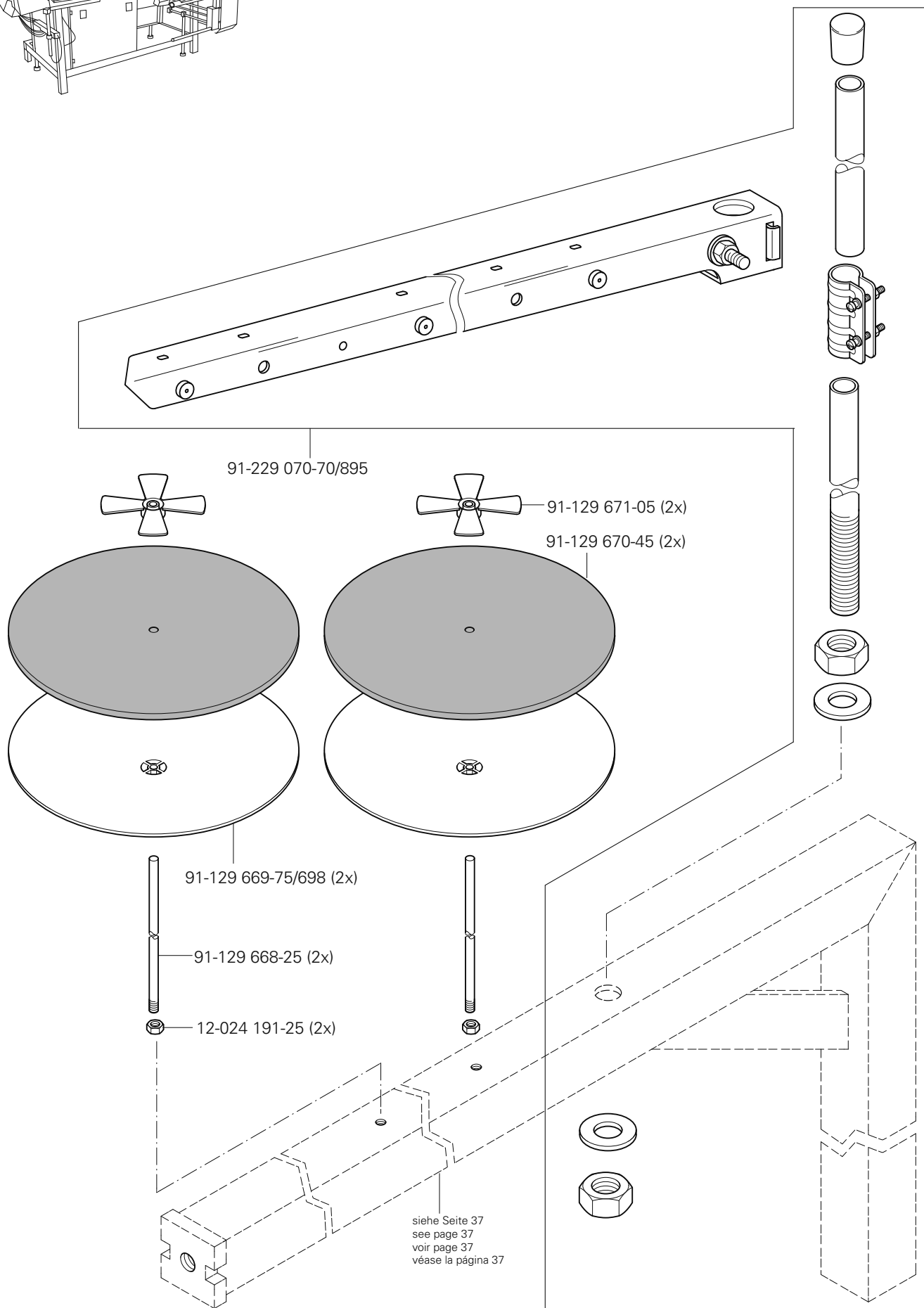

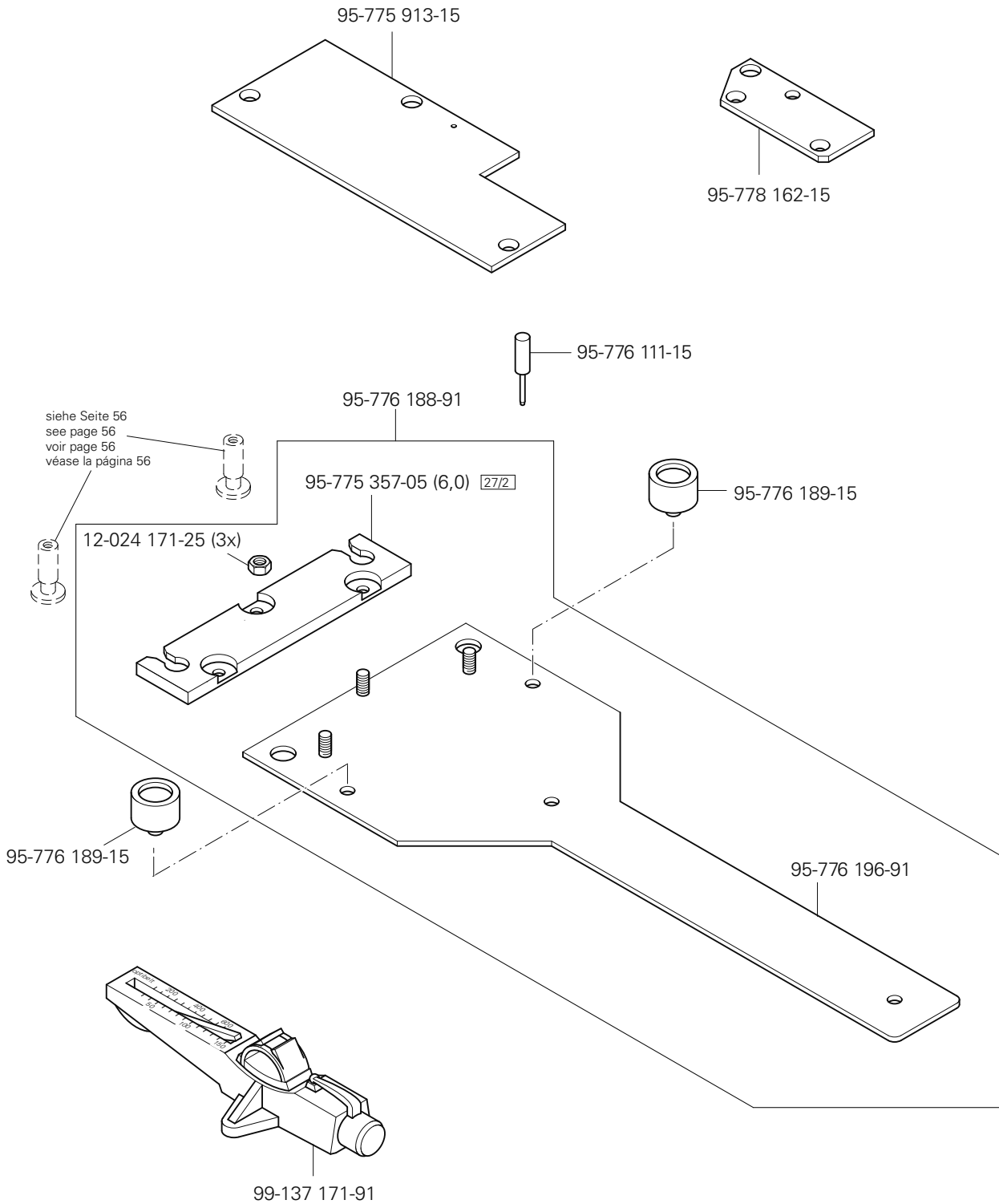
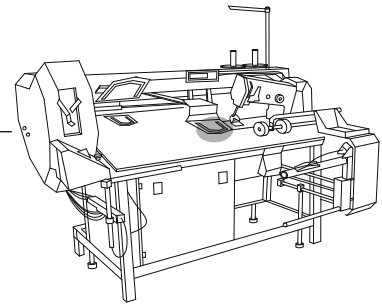

Schmiermittel-Übersicht

Overview of lubricants

Tableau de lubrifiants

Tabla de lubricantes

PFAFF 3588-05/020

14

Öl Oil Huile Aceite	Mittelpunkts-Viskosität bei: Mean viscosity at: Viscosité moyenne à: Viscosidad media a:		Dichte bei: Density of: Densité à: Densidad a:		Bestellnummer für Behälter mit: Part number for can with: Numéro de commande pour récipientsavec: Número de pedido para recipientes con:		
	°C	mm ² /s	°C	g/cm ³ (g/ml)	1 Liter 1 Litre 1 Litro		
28-011 201-44	40	22,0	15	0,865	91-129 917-91		

Fett Grease Graisse Grasa	Penetration Penetration Pénétración Penetración	Tropfpunkt Drip-point Point de suintement Punto de goteo	Bestellnummer für Behälter mit: Part number for can with: Numéro de commande pour récipientsavec: Número de pedido para recipientes con:				
			mm/10	°C	0,25 kg	0,5 kg	1 kg
28-011 202-05							28-011 202-05
28-011 202-10		185					28-011 202-10
28-011 202-43	375-405	150				28-011 202-43	
28-011 202-47	220-250	185					28-011 202-47

15

Abweichende Teile der PFAFF 3588-15/020
 Different parts for PFAFF 3588-15/020
 Pièces divergentes de la PFAFF 3588-15/020
 Piezas de la PFAFF 3588-15/020 que son diferentes

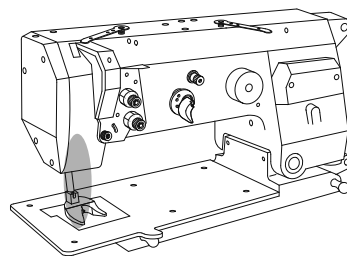

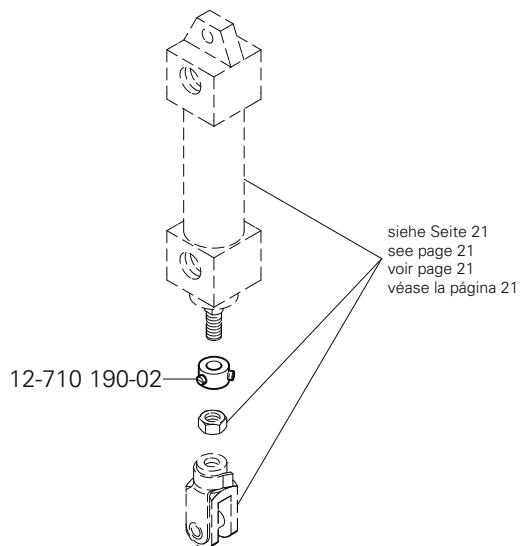
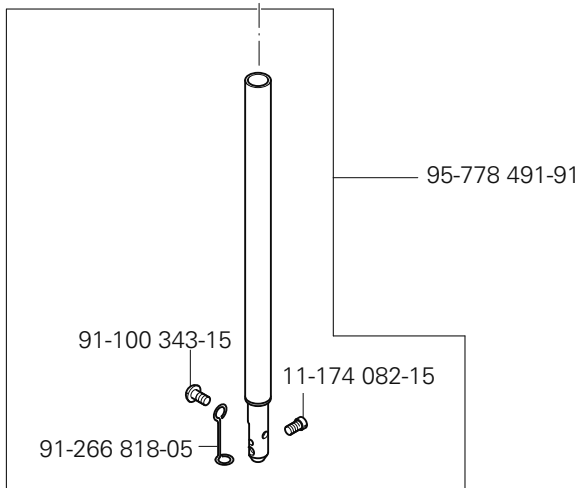
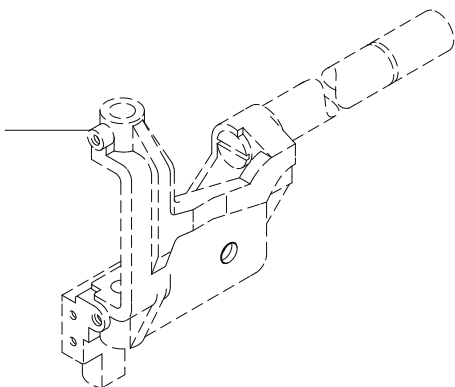

siehe Seite 13
 see page 13
 voir page 13
 véase la página 13

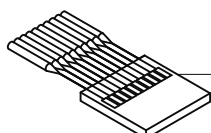

siehe Seite 21
 see page 21
 voir page 21
 véase la página 21



System 134-35 
 Systeme 134-35 
 Sistema 134-35 

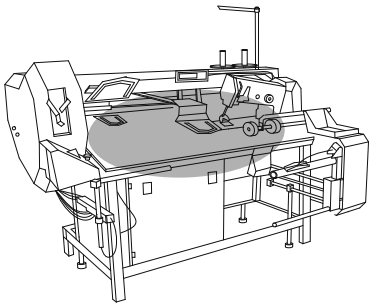

Abweichende Teile der PFAFF 3588-15/020
 Different parts for PFAFF 3588-15/020
 Pièces divergentes de la PFAFF 3588-15/020
 Piezas de la PFAFF 3588-15/020 que son diferentes

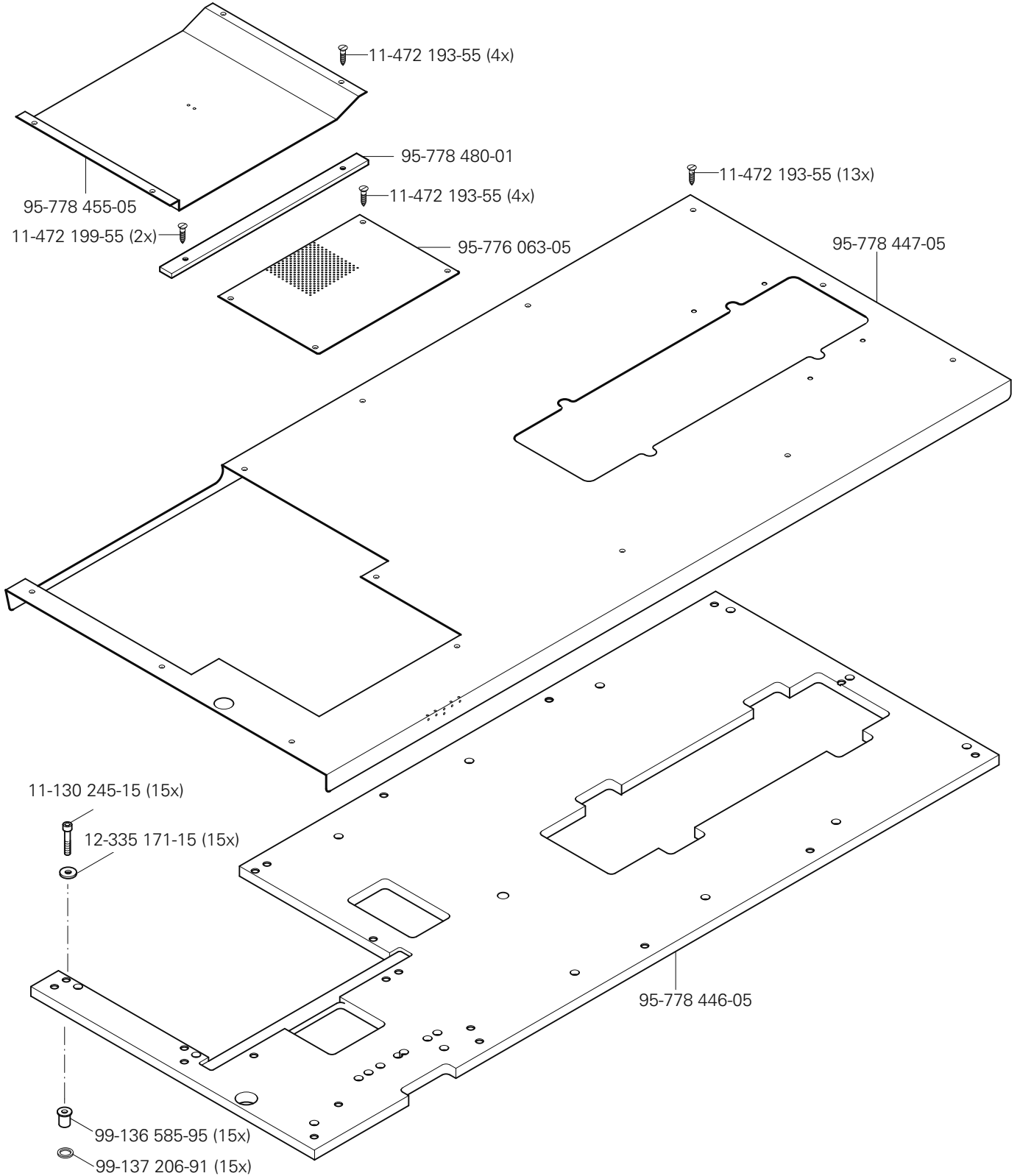

15

Abweichende Teile der PFAFF 3588-15/020
 Different parts for PFAFF 3588-15/020
 Pièces divergentes de la PFAFF 3588-15/020
 Piezas de la PFAFF 3588-15/020 que son diferentes

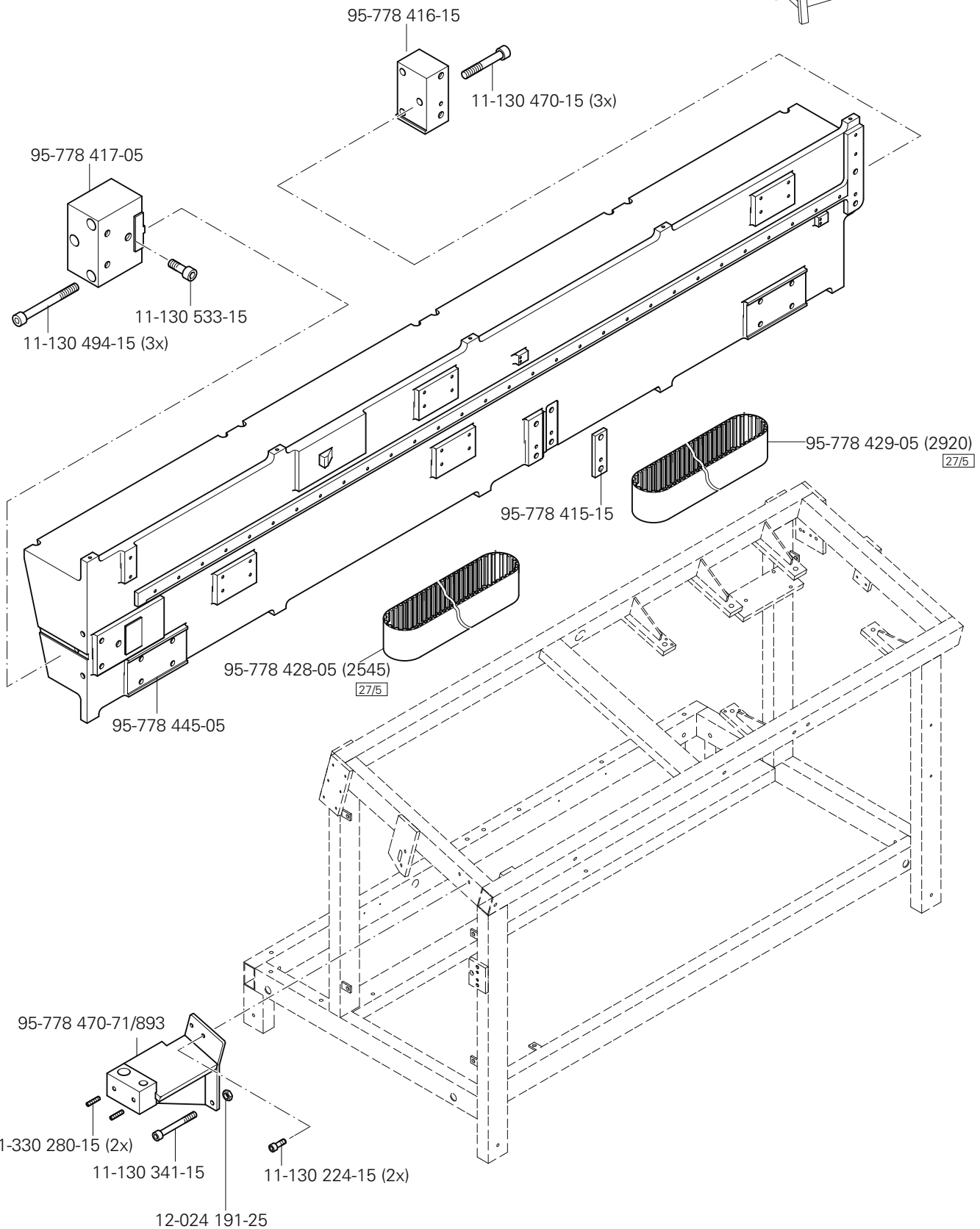
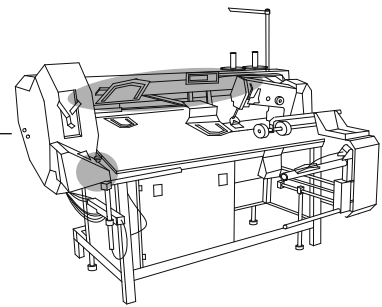

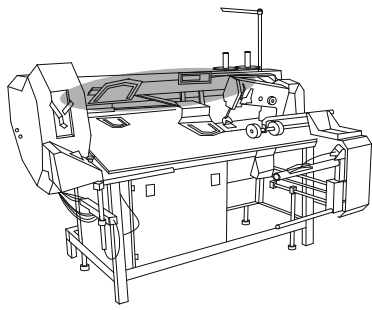

Abweichende Teile der PFAFF 3588-15/020
 Different parts for PFAFF 3588-15/020
 Pièces divergentes de la PFAFF 3588-15/020
 Piezas de la PFAFF 3588-15/020 que son diferentes

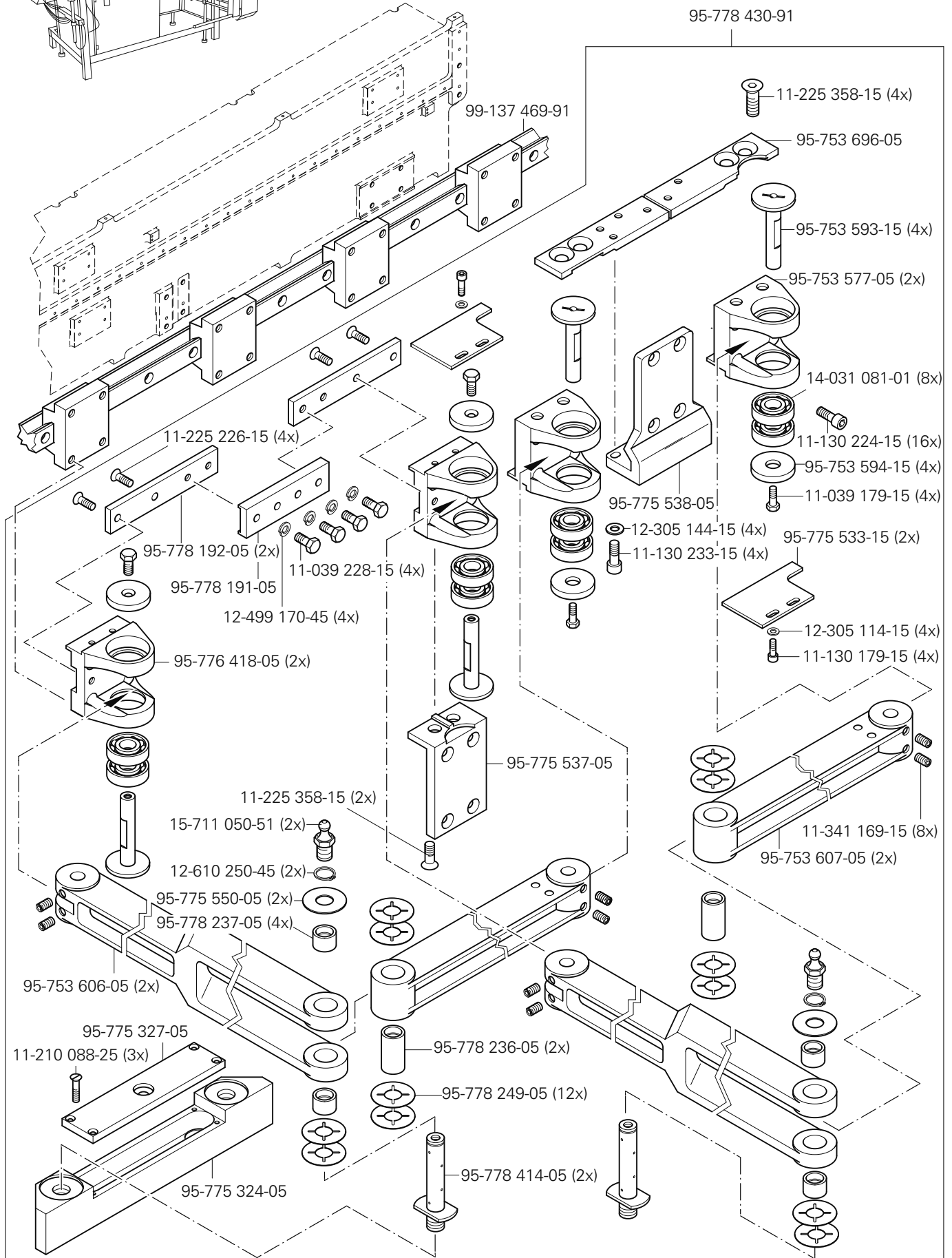

15

Abweichende Teile der PFAFF 3588-15/020
 Different parts for PFAFF 3588-15/020
 Pièces divergentes de la PFAFF 3588-15/020
 Piezas de la PFAFF 3588-15/020 que son diferentes

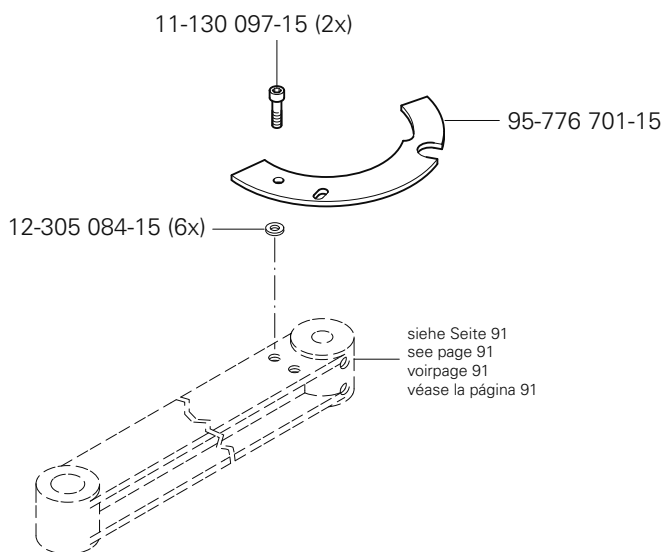
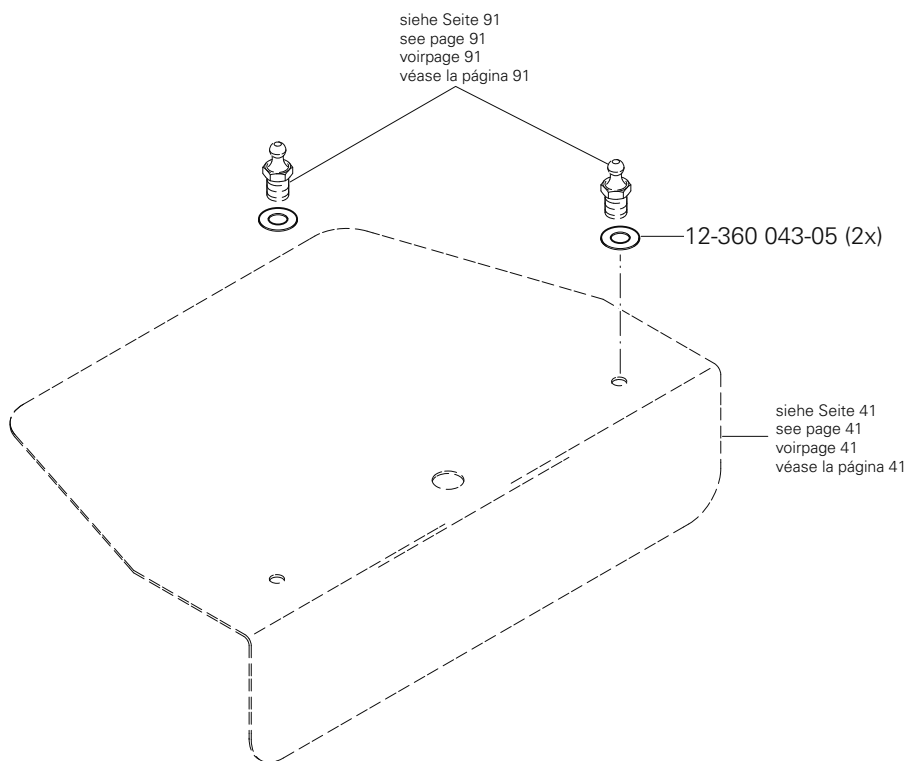
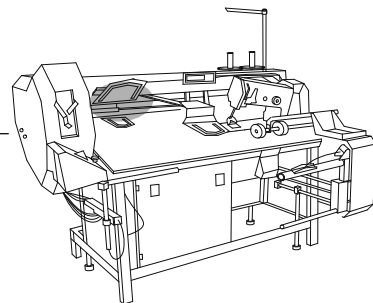

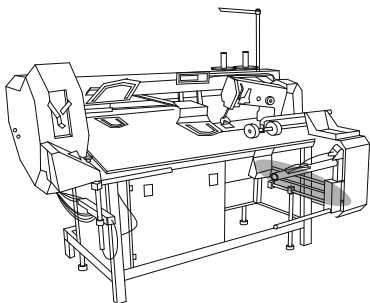

Abweichende Teile der PFAFF 3588-15/020
 Different parts for PFAFF 3588-15/020
 Pièces divergentes de la PFAFF 3588-15/020
 Piezas de la PFAFF 3588-15/020 que son diferentes

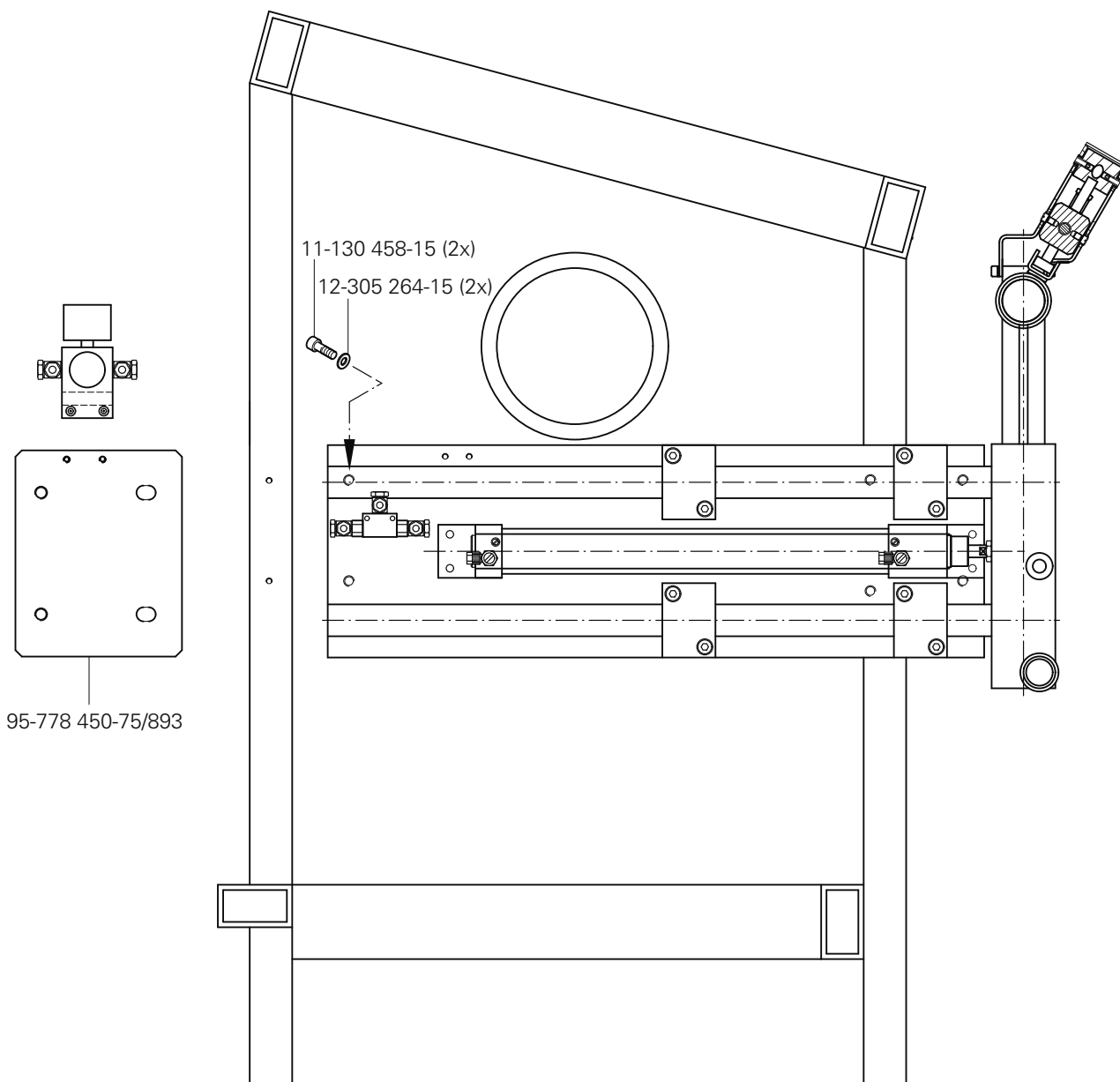

15

Abweichende Teile der PFAFF 3588-15/020
 Different parts for PFAFF 3588-15/020
 Pièces divergentes de la PFAFF 3588-15/020
 Piezas de la PFAFF 3588-15/020 que son diferentes

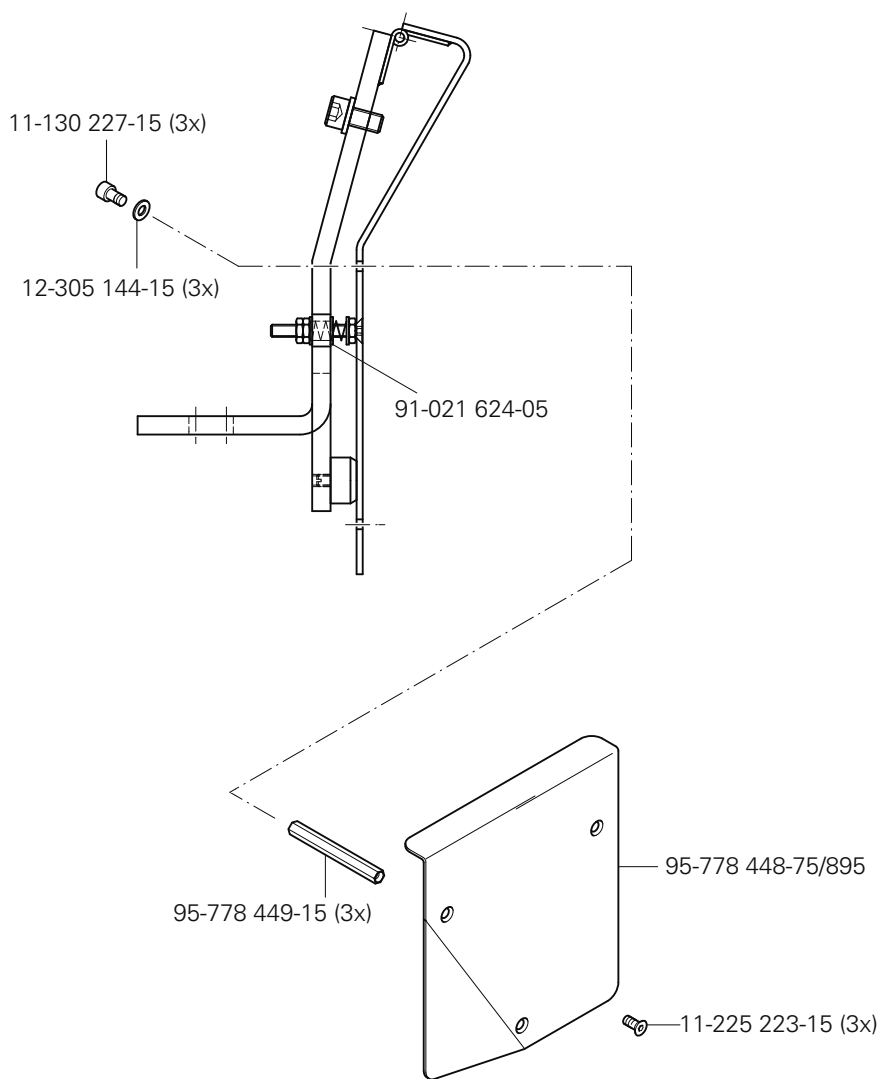
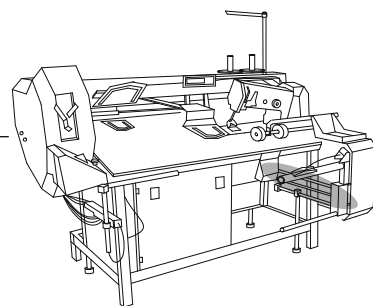

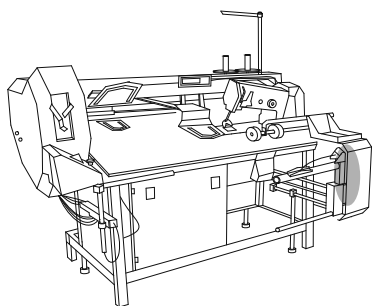

Abweichende Teile der PFAFF 3588-15/020
 Different parts for PFAFF 3588-15/020
 Pièces divergentes de la PFAFF 3588-15/020
 Piezas de la PFAFF 3588-15/020 que son diferentes

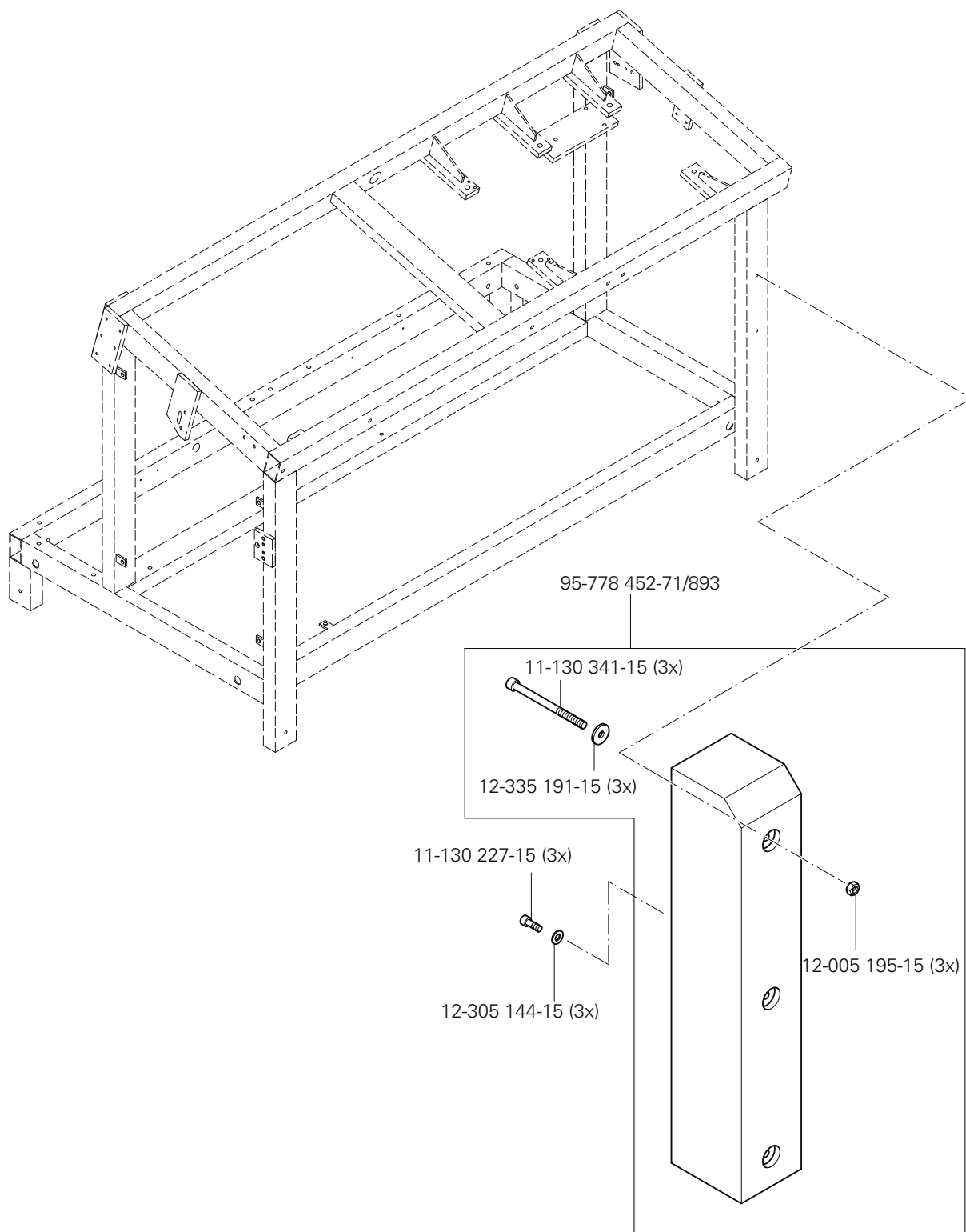

16.01

Höhenverstellung für Gestell
 Vertical adjustment for frame
 Réglage de la hauteur du bâti
 Regulación de la altura del bastidor

PFAFF 3588-05/020
 PFAFF 3588-15/020

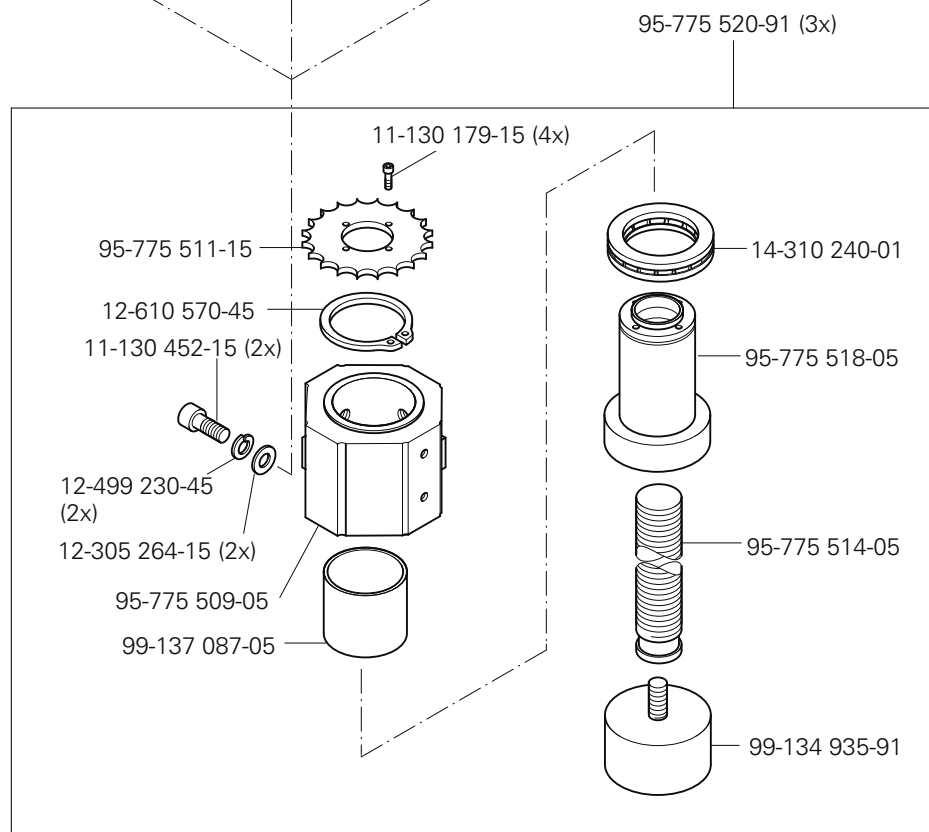
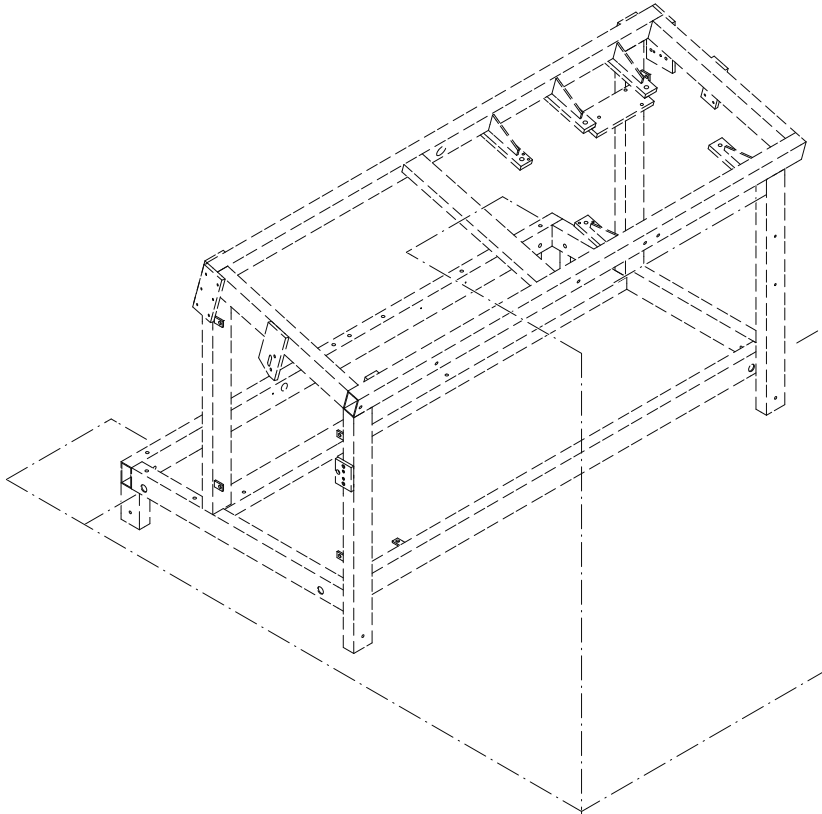
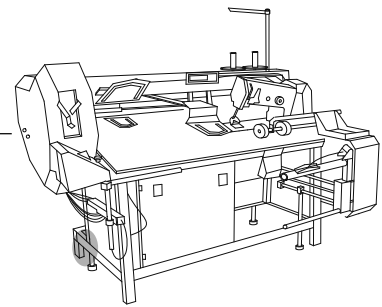

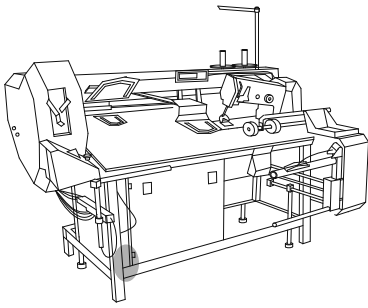

Höhenverstellung für Gestell
 Vertical adjustment for frame
 Réglage de la hauteur du bâti
 Regulación de la altura del bastidor

PFAFF 3588-05/020
 PFAFF 3588-15/020

16.01

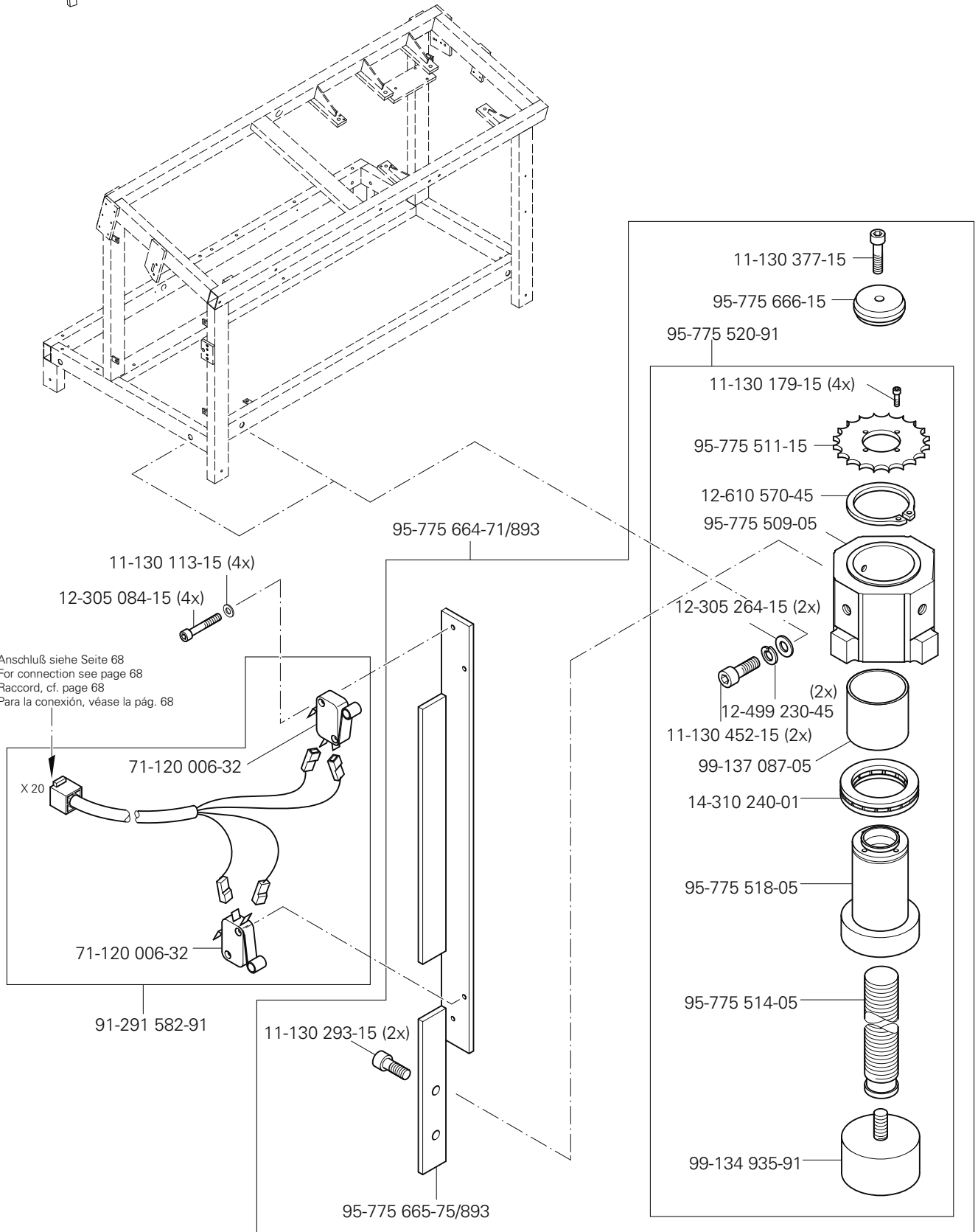

Anschluß siehe Seite 68
 For connection see page 68
 Raccord, cf. page 68
 Para la conexión, véase la pág. 68

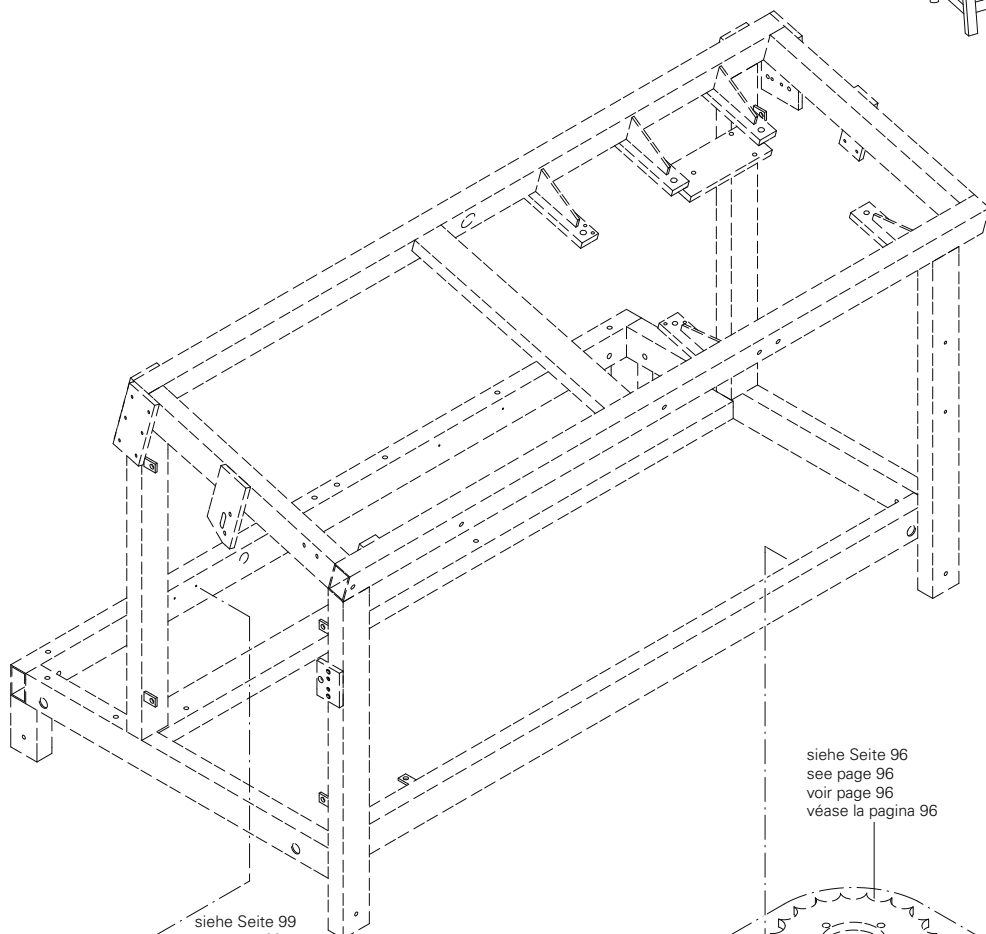
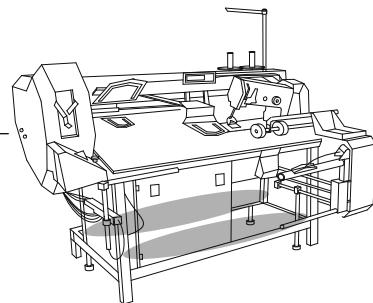

siehe Seite 96
 see page 96
 voir page 96
 véase la pagina 96

siehe Seite 96
 see page 96
 voir page 96
 véase la pagina 96

siehe Seite 99
 see page 99
 voir page 99
 véase la pagina 99

siehe Seite 96
 see page 96
 voir page 96
 véase la pagina 96

11-130 197-15 (4x)

95-775 880-05

12-335 151-15 (4x)

12-335 151-15 (4x)

11-130 197-15 (4x)

95-775 880-05

95-775 880-05

95-776 015-91

95-775 880-05

siehe Seite 97
 see page 97
 voir page 97
 véase la pagina 97

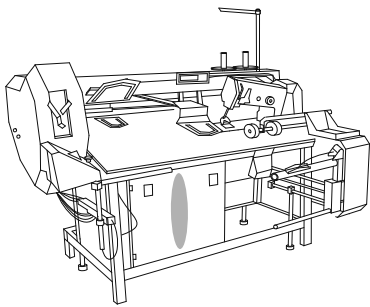

Höhenverstellung für Gestell
 Vertical adjustment for frame
 Réglage de la hauteur du bâti
 Regulación de la altura del bastidor

PFAFF 3588-05/020
 PFAFF 3588-15/020

16.01

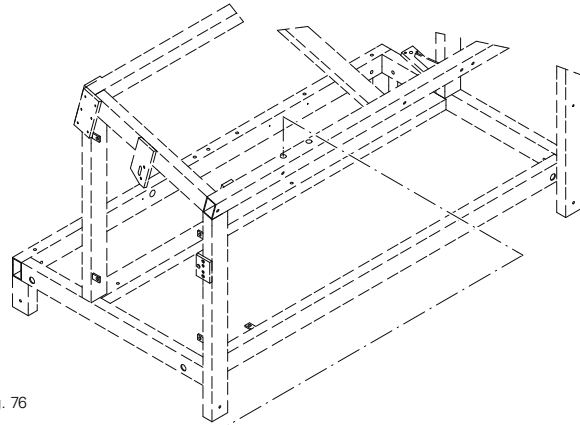

Anschluß siehe Seite 76
 For connection see page 76
 Raccord, cf. page 76
 Para la conexión, véase la pág. 76

91-291 583-91

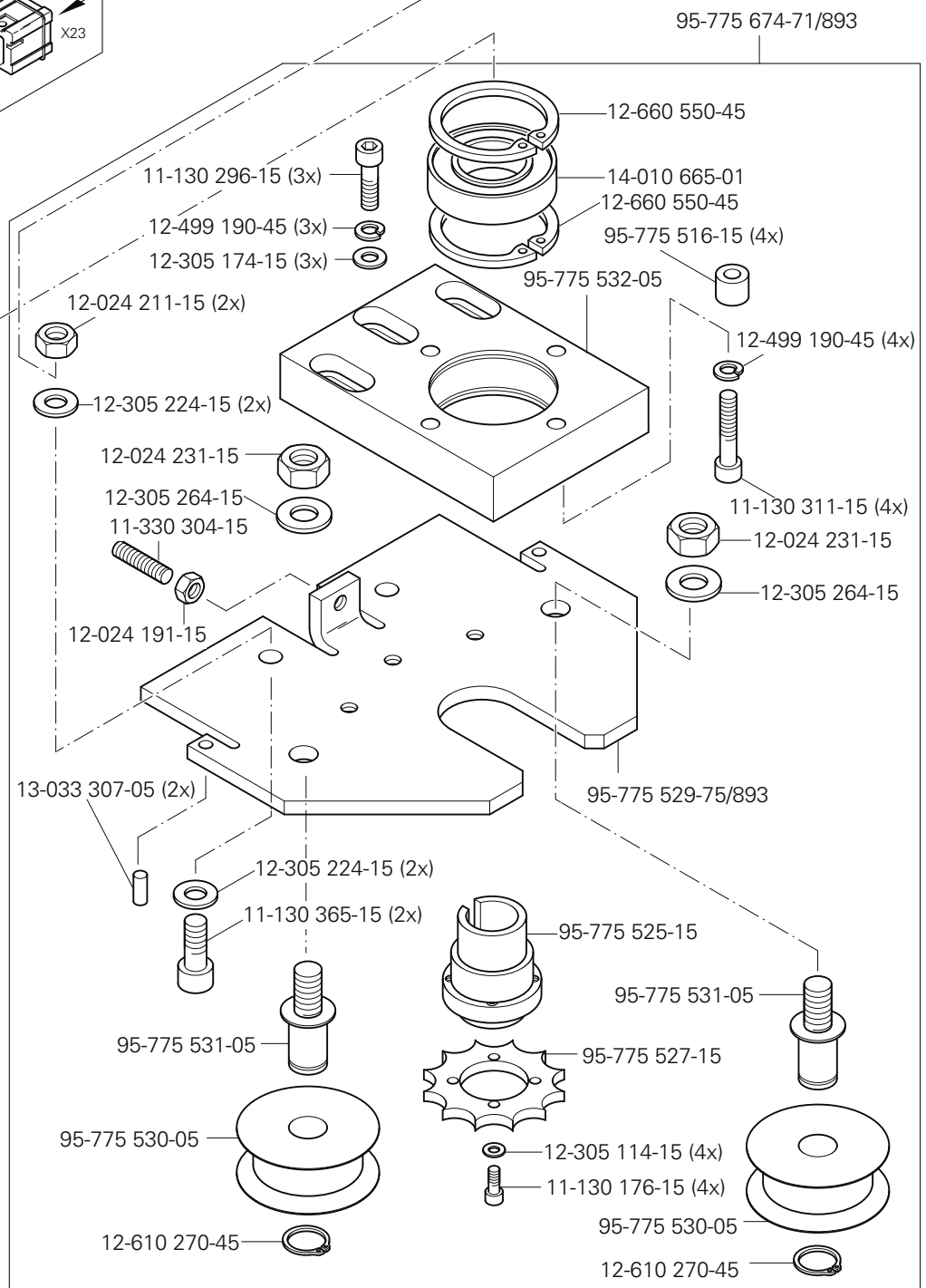
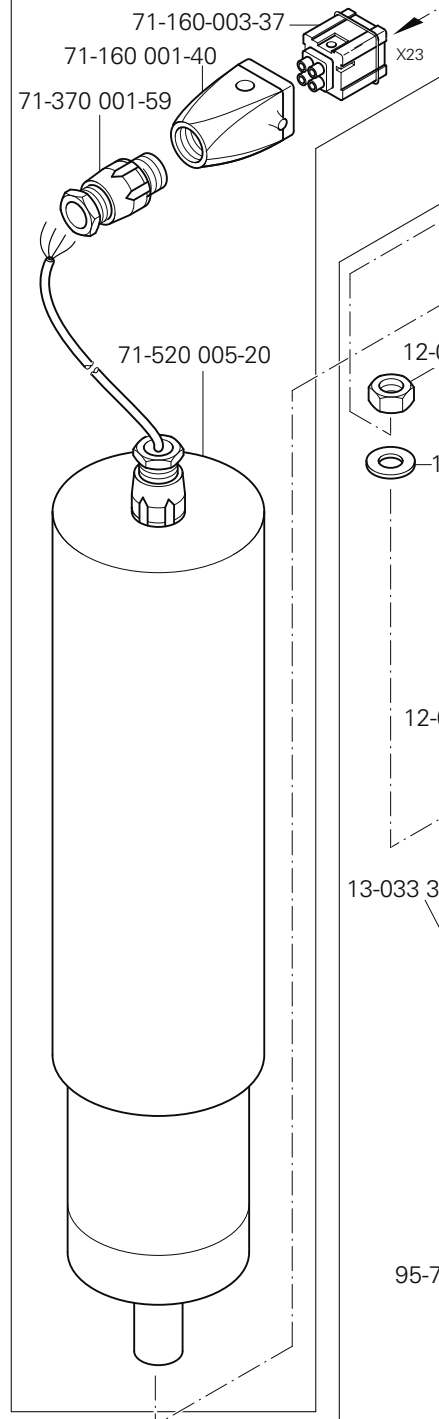

16.01

Höhenverstellung für Gestell
 Vertical adjustment for frame
 Réglage de la hauteur du bâti
 Regulación de la altura del bastidor

PFAFF 3588-05/020
 PFAFF 3588-15/020

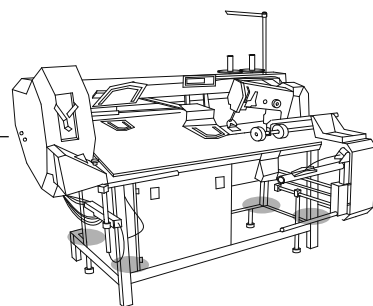

95-775 851-75/893

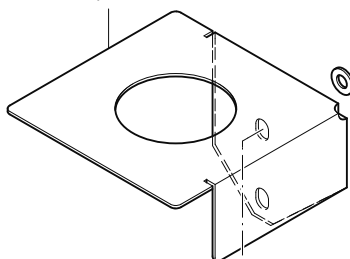

11-130 293-15 (2x)
 12-305 174-15 (2x)

95-775 851-75/893

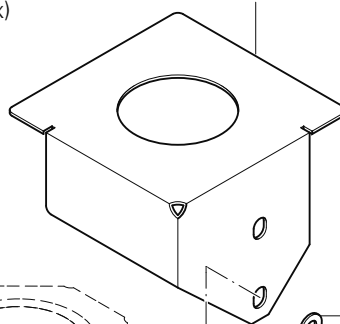

siehe Seite 96
 see page 96
 voir page 96
 véase la página 96

12-305 174-15 (2x)

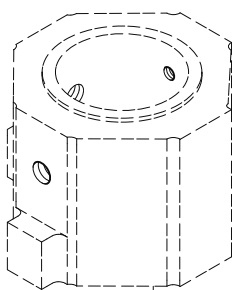

11-130 293-15 (2x)

siehe Seite 96
 see page 96
 voir page 96
 véase la página 96

11-130 293-15 (2x)

12-305 174-15 (2x)

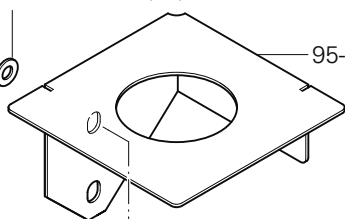

95-775 851-75/893

95-775 851-75/893

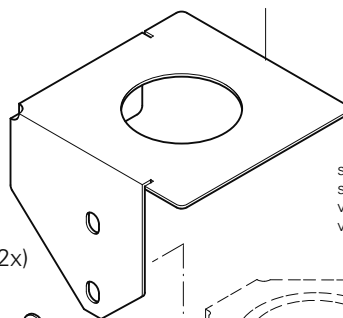

siehe Seite 96
 see page 96
 voir page 96
 véase la página 96

11-130 293-15 (2x)

12-305 174-15 (2x)

siehe Seite 97
 see page 97
 voir page 97
 véase la página 97

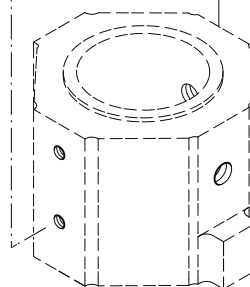
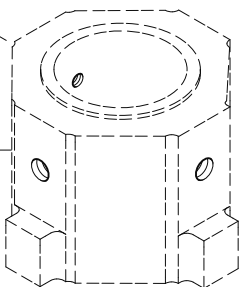

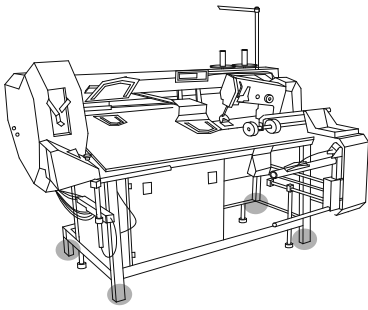

Transportrolle
 Feed roller
 Galet d'entraînement
 Rodillo el transporte

PFAFF 3588-05/020
 PFAFF 3588-15/020

16.02

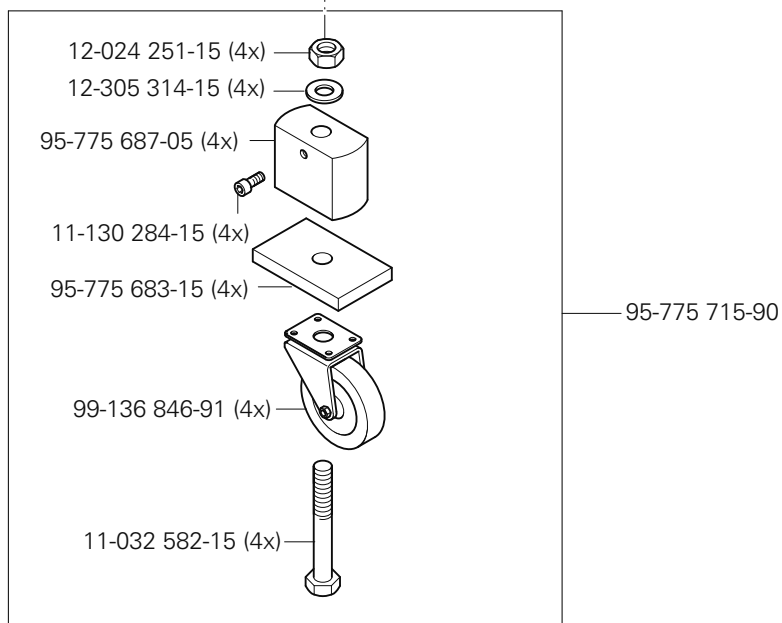
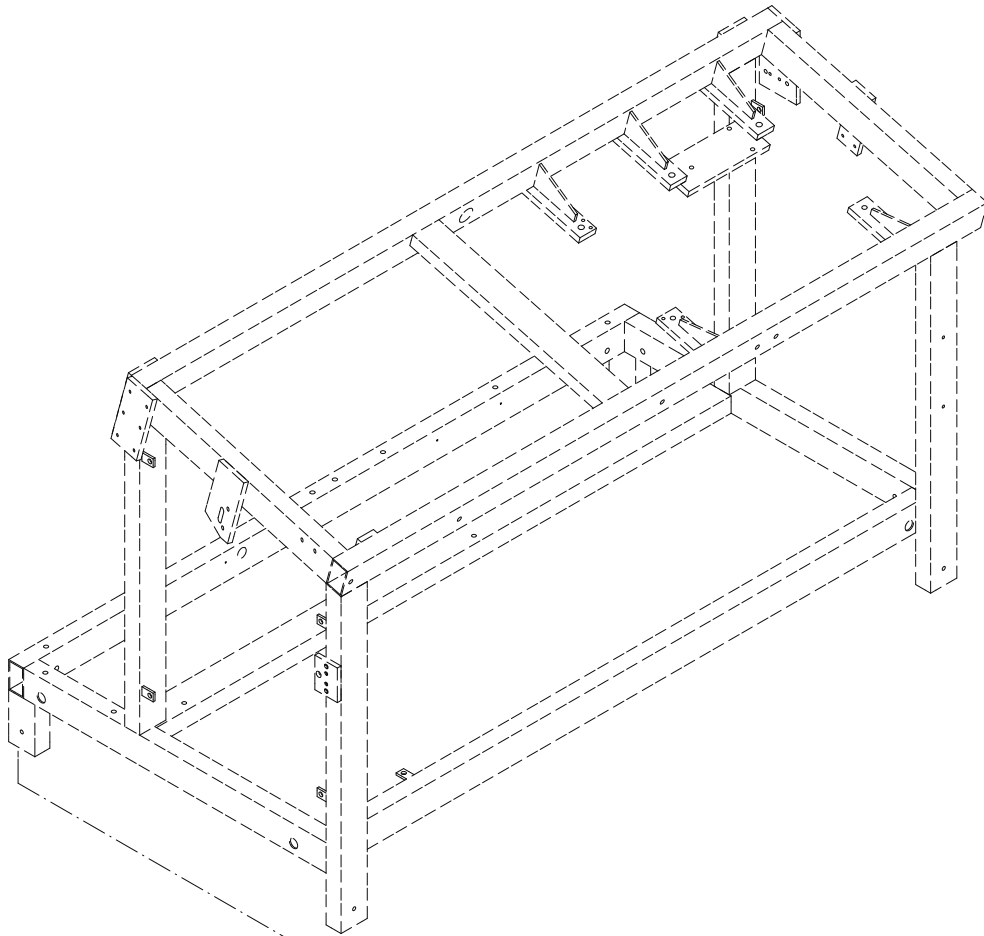

16.03

Anbausatz für Programmerkennung

Add-on kit for program identification

Kit pour reconnaissance de programme

Kit para identificación del programa

PFAFF 3588-05/020

PFAFF 3588-15/020

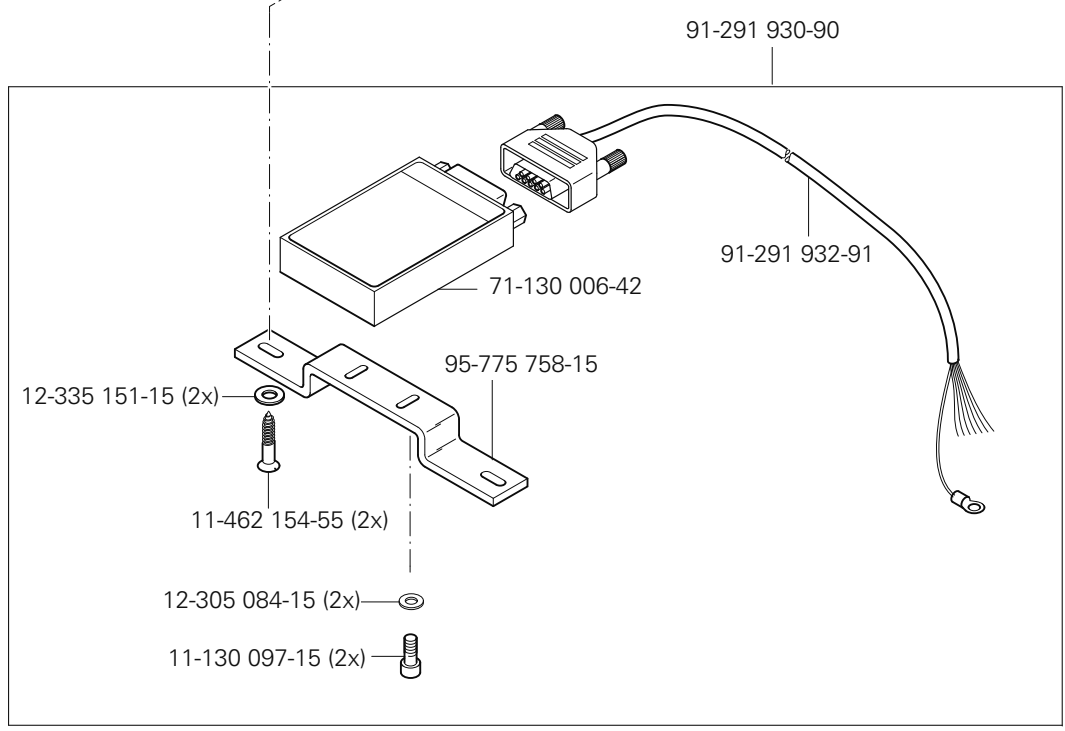
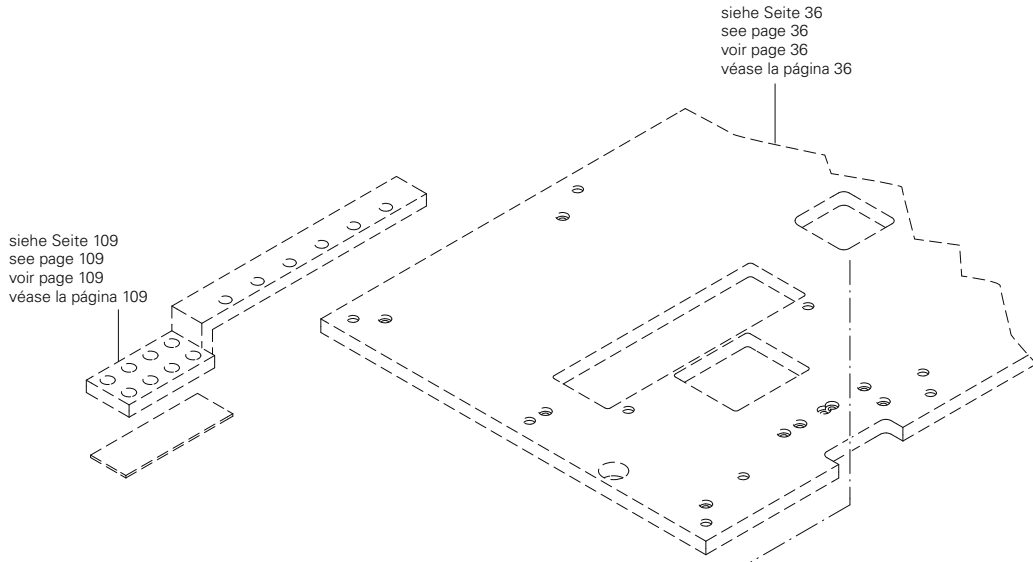
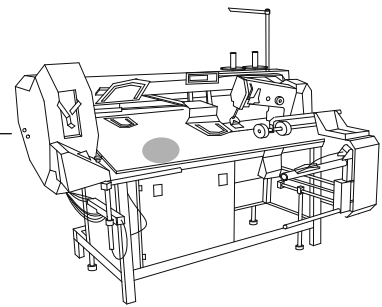

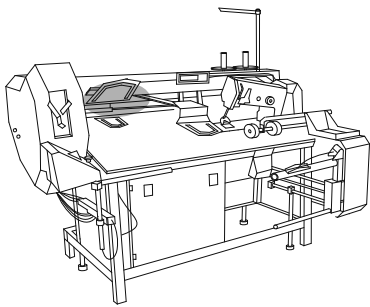

Anbausatz für Magnet
 Add-on kit for solenoid
 Jeu de pièces adaptables pour electro-aimant
 Juego de piezas acoptables para Electroimán

PFAFF 3588-05/020
 PFAFF 3588-15/020

16.04

91-291-920-90

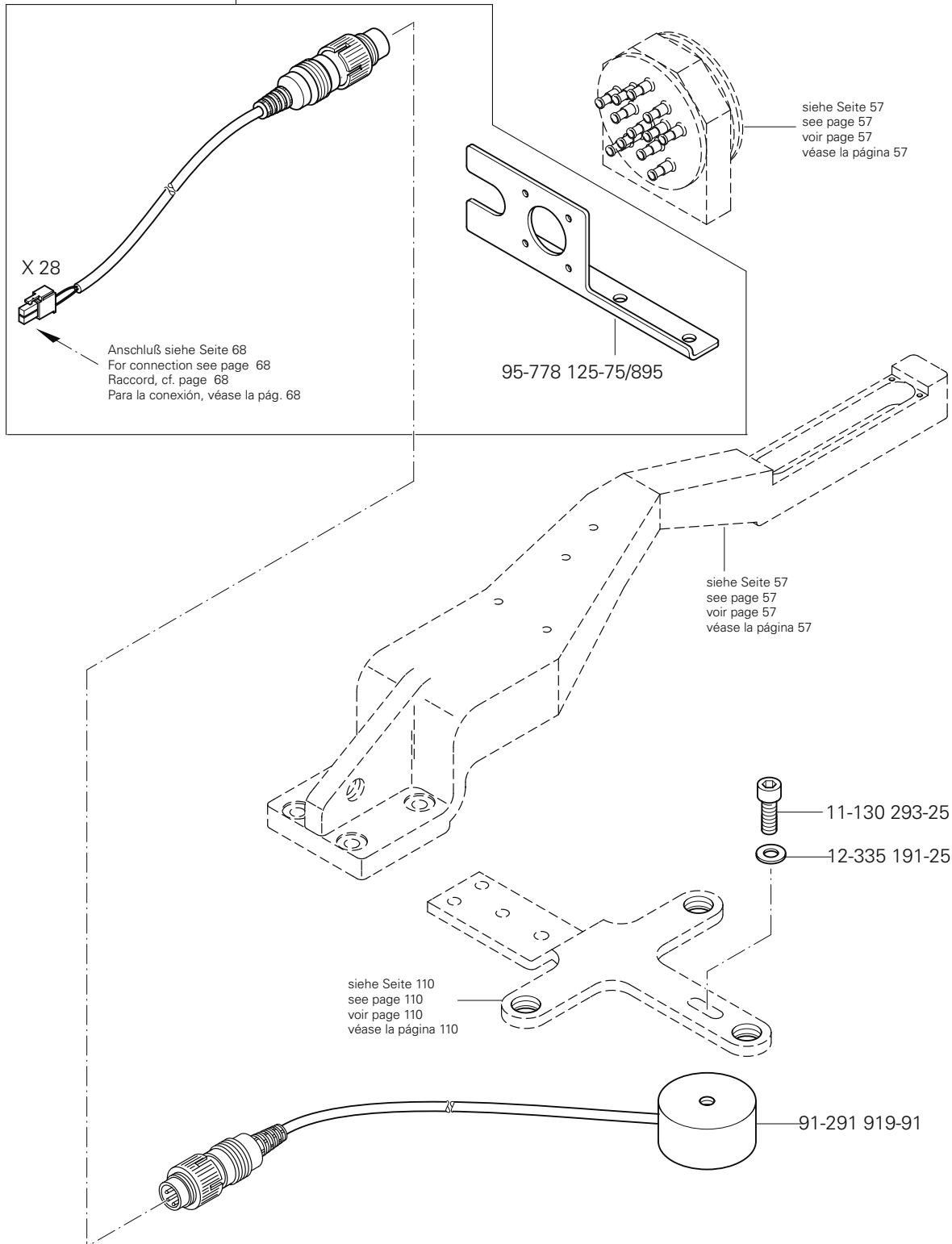

16.05

Bausatz für breiten Saum

Kit for wide hem

Kit pour ourlet large

Juego de montaje para dobladillo ancho PFAFF 3588-05/020

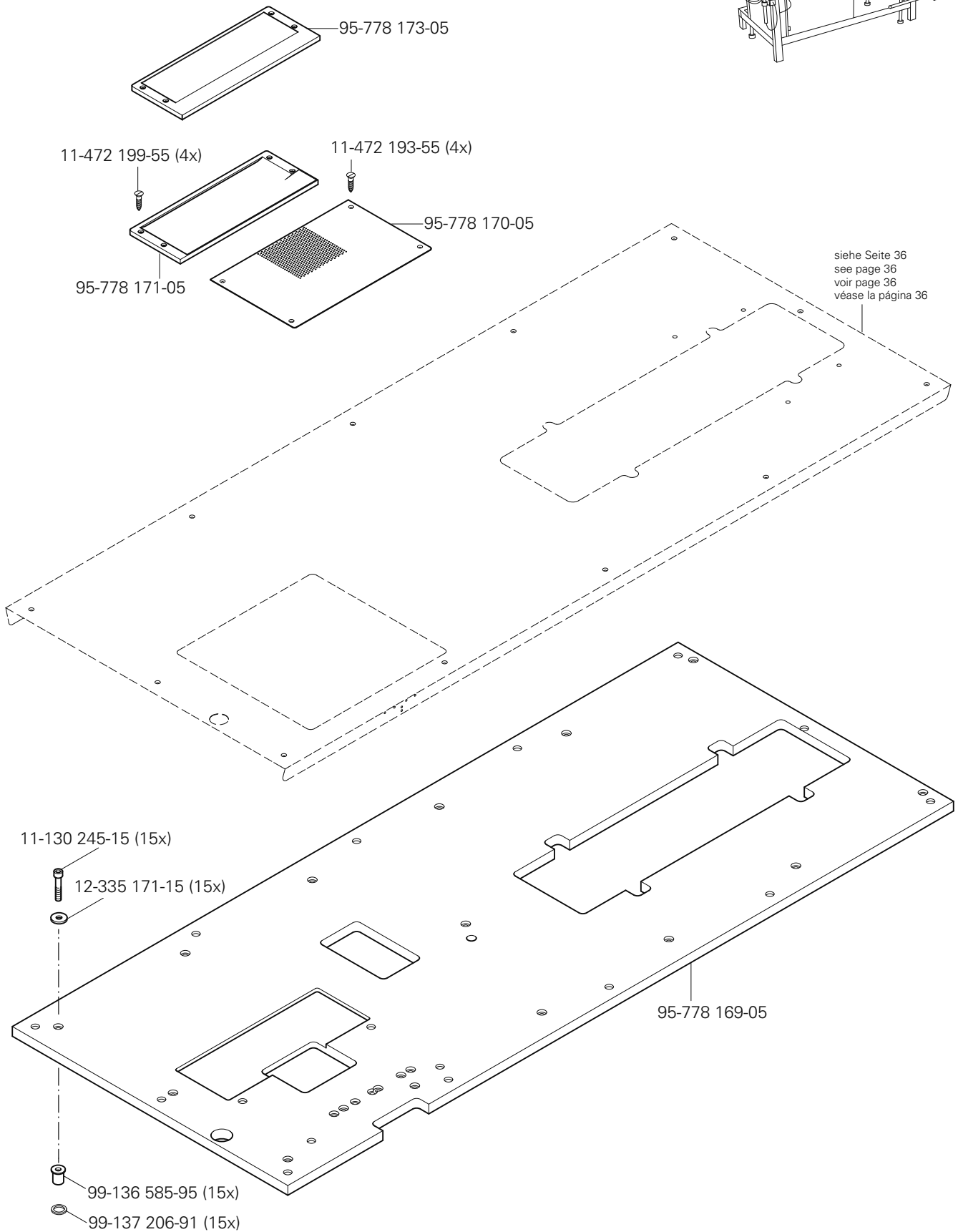
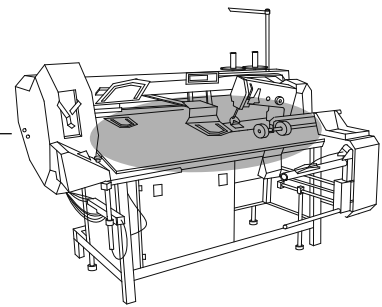

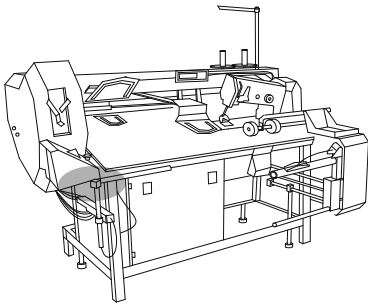

Ablagebox
Collection box
Boîte à prince
Caja de apilado

PFAFF 3588-05/020
PFAFF 3588-15/020

16.06

95-778 481-91

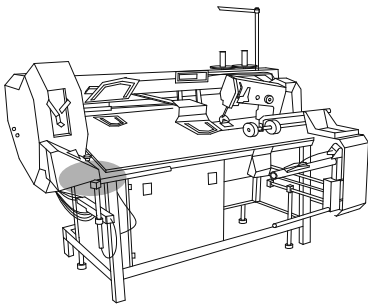
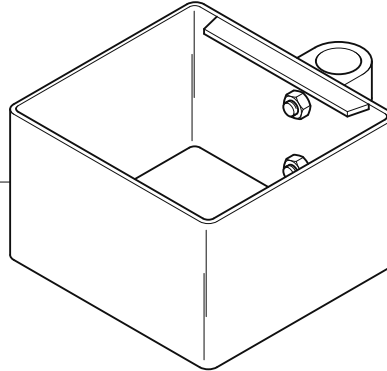

Halter für Laser
Laser part set holder
Support à laser
Sujeción de laser

PFAFF 3588-05/020
PFAFF 3588-15/020

16.07

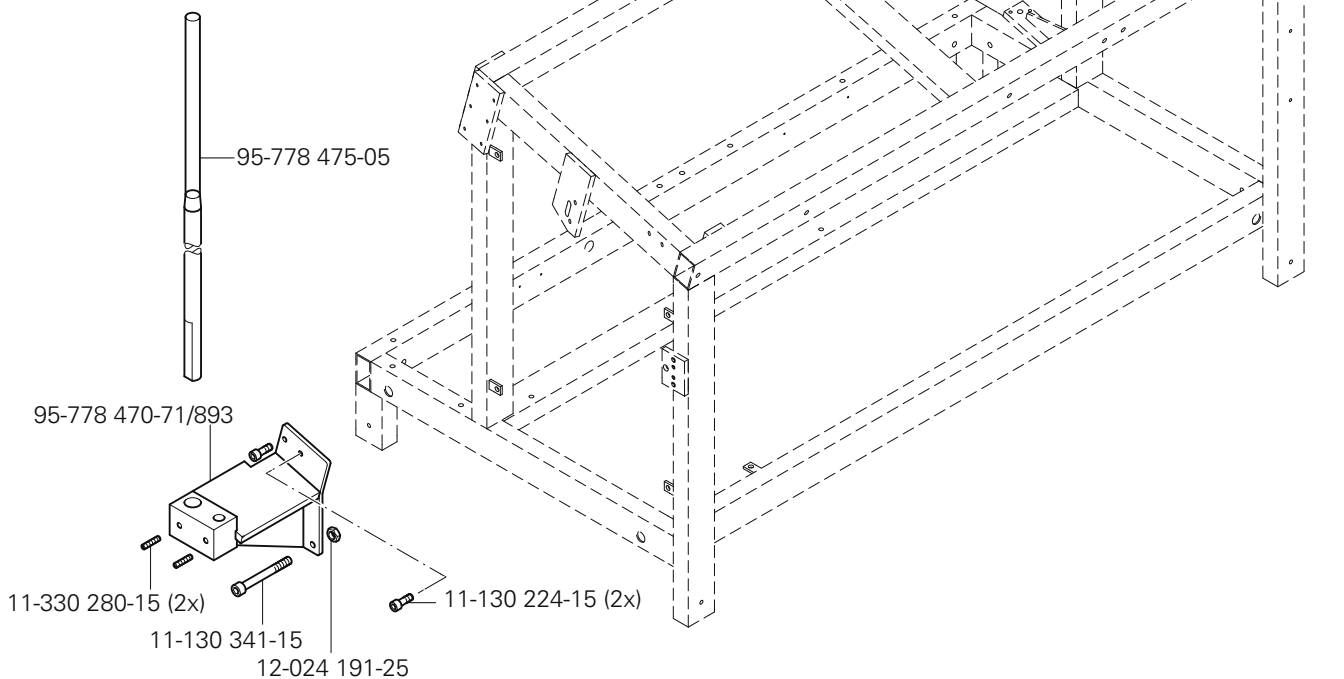

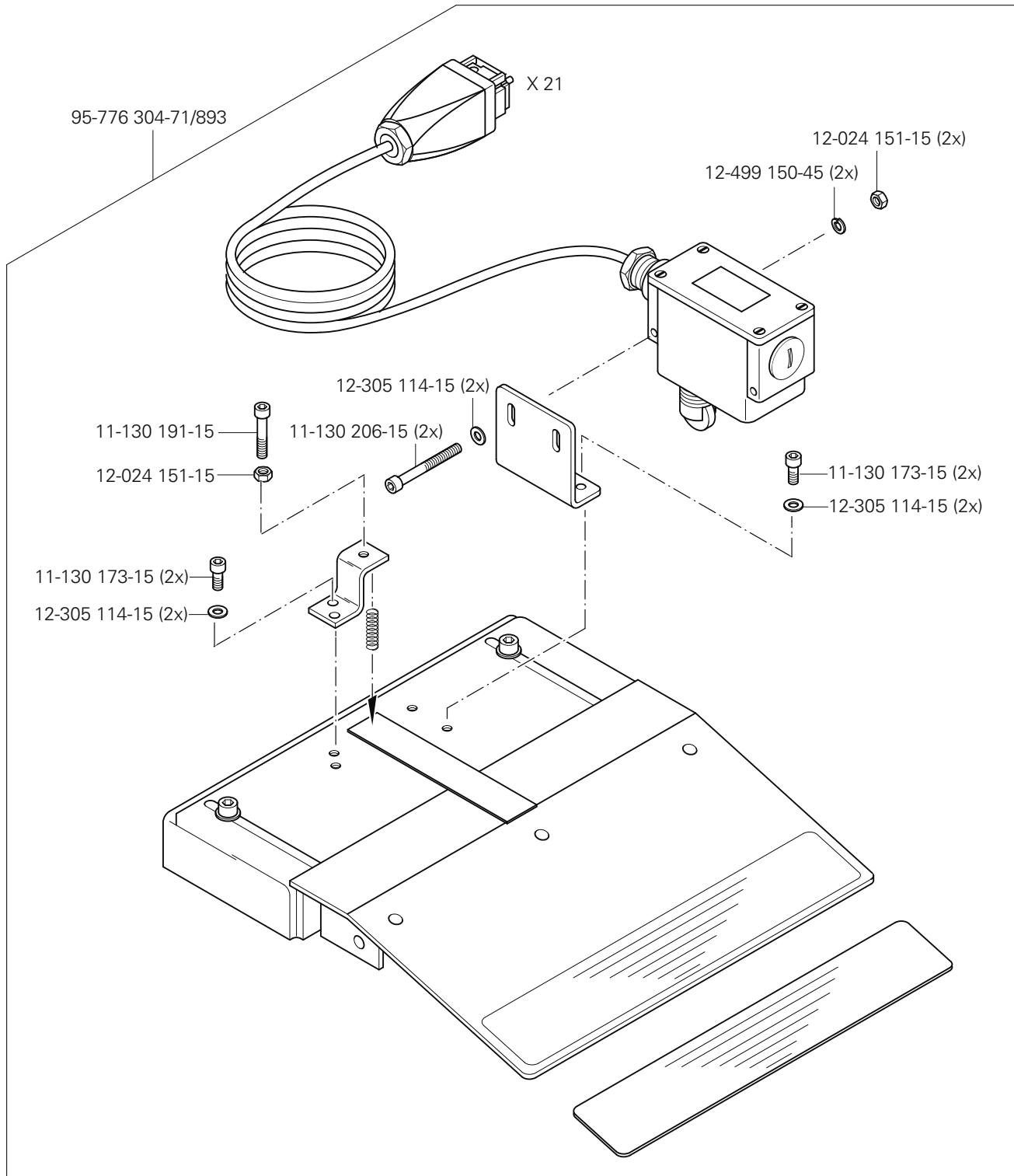
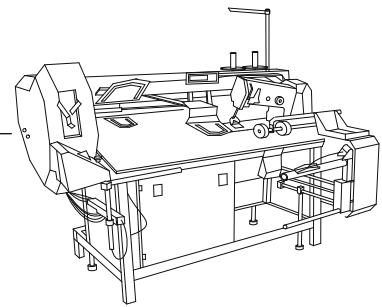

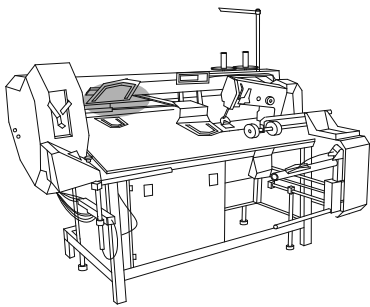

Teilesatz vollst. (Standardausführung)
 Part set assy. (Standard version)
 Jeu de pièces comp. (Version standard)
 Juego de piezas compl. (tipo estándar)

PFAFF 3588-05/020
 PFAFF 3588-15/020

16.09

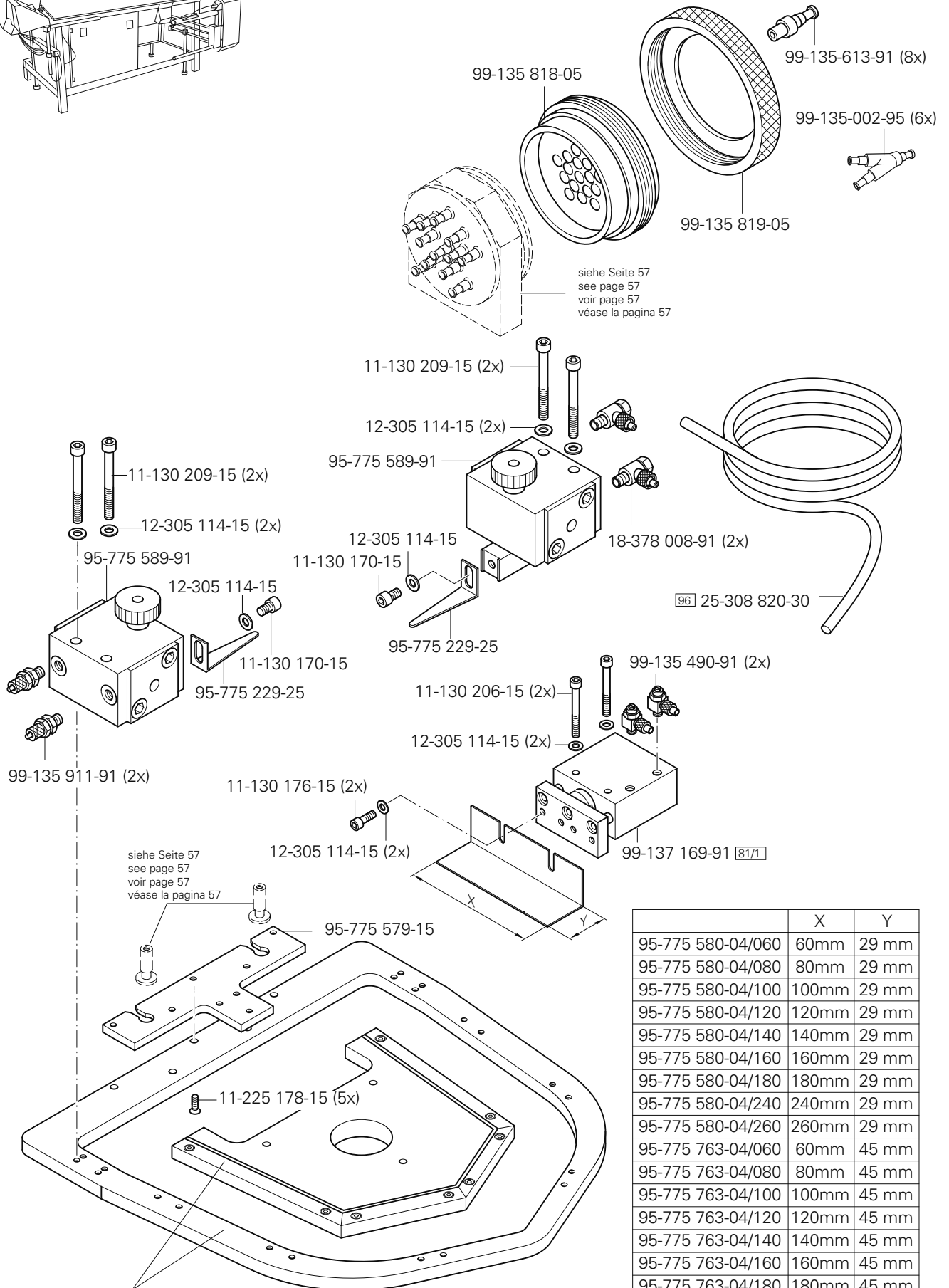

	X	Y
95-775 580-04/060	60mm	29 mm
95-775 580-04/080	80mm	29 mm
95-775 580-04/100	100mm	29 mm
95-775 580-04/120	120mm	29 mm
95-775 580-04/140	140mm	29 mm
95-775 580-04/160	160mm	29 mm
95-775 580-04/180	180mm	29 mm
95-775 580-04/240	240mm	29 mm
95-775 580-04/260	260mm	29 mm
95-775 763-04/060	60mm	45 mm
95-775 763-04/080	80mm	45 mm
95-775 763-04/100	100mm	45 mm
95-775 763-04/120	120mm	45 mm
95-775 763-04/140	140mm	45 mm
95-775 763-04/160	160mm	45 mm
95-775 763-04/180	180mm	45 mm
95-775 763-04/240	240mm	45 mm
95-775 763-04/260	260mm	45 mm

Bei Bestellung bitte die Nummer auf dem Stempel angeben
 In your order please quote the number on the die
 Prière d'indiquer à la commande le numéro sur le tampon
 En el pedido, se ruega indicar el número en el sello.

16.09

Teilesatz vollst. (Standardausführung)
 Part set assy. (Standard version)
 Jeu de pièces comp. (Version standard)
 Juego de piezas compl. (tipo estándar)

PFAFF 3588-05/020
 PFAFF 3588-15/020

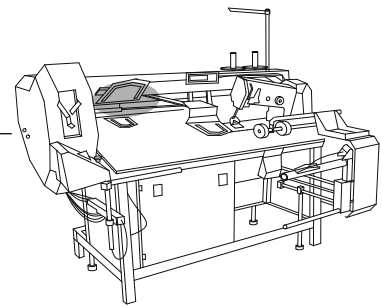

Bei Bestellung bitte die Nummer auf dem Taschenblech angeben
 In your order please quote the number on the pocket plate
 Prière d'indiquer à la commande le numéro sur la plaque métallique de poche
 En el pedido, se ruega indicar el número en la chapa de bolsillo.

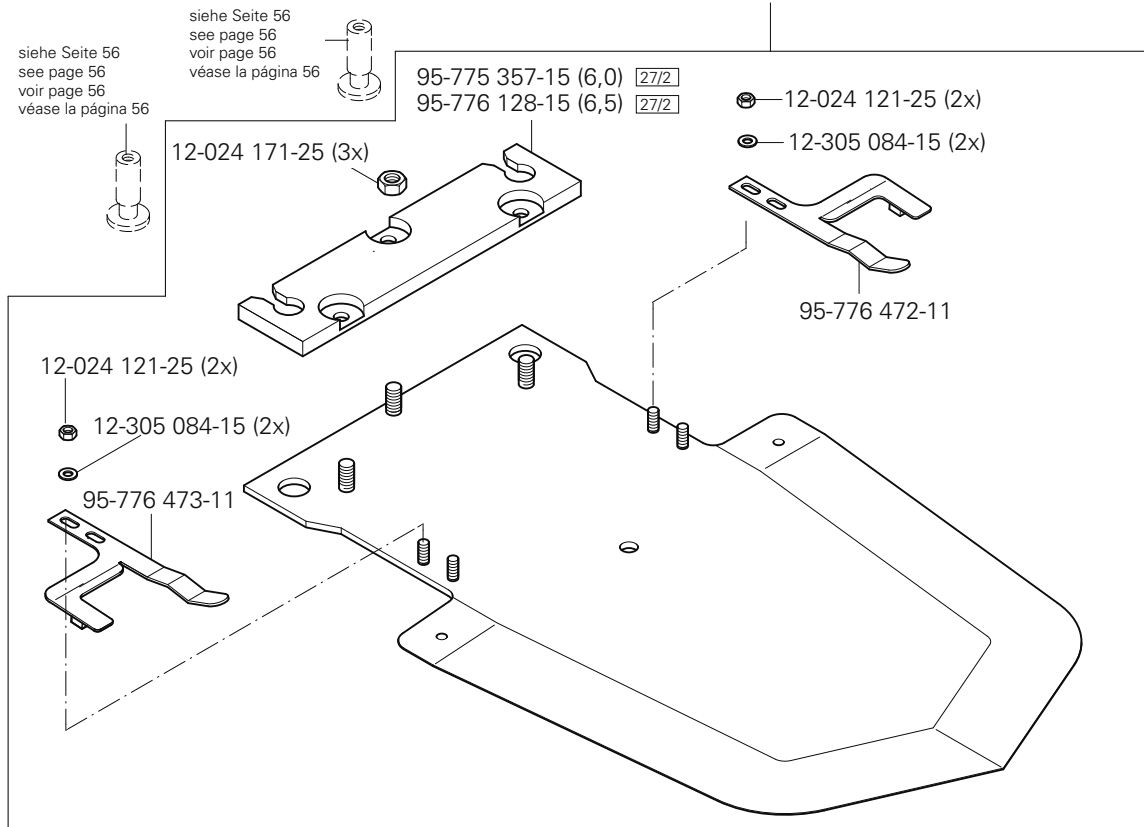

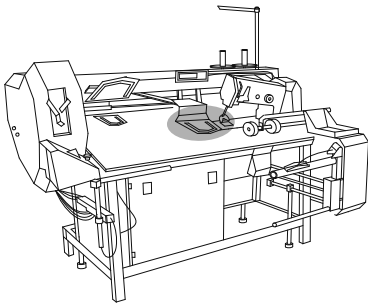

Teilesatz vollst. (Standardausführung)

Part set assy. (Standard version)

Jeu de pièces comp. (Version standard)

Juego de piezas compl. (tipo estándar)

PFAFF 3588-05/020

PFAFF 3588-15/020

16.09

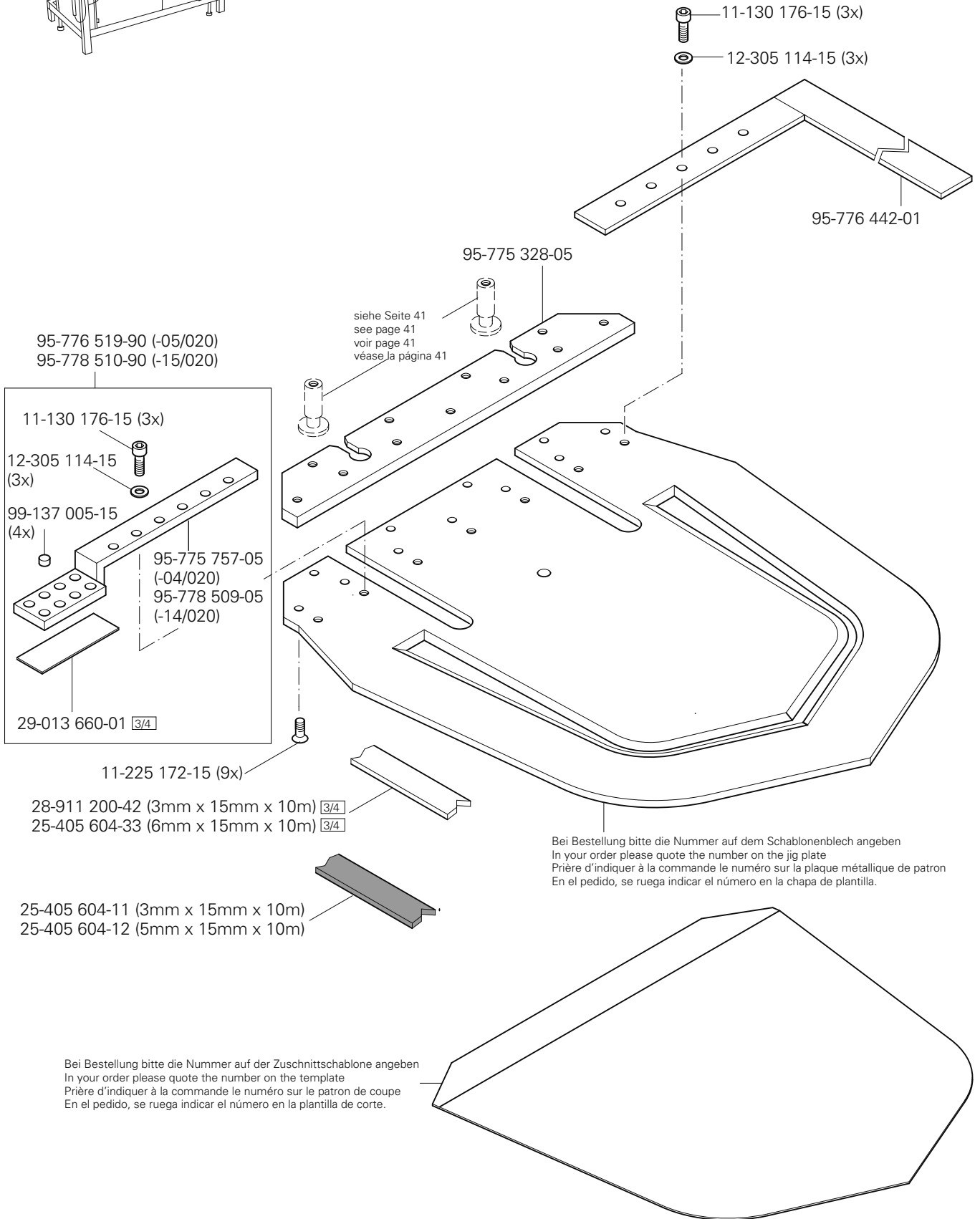

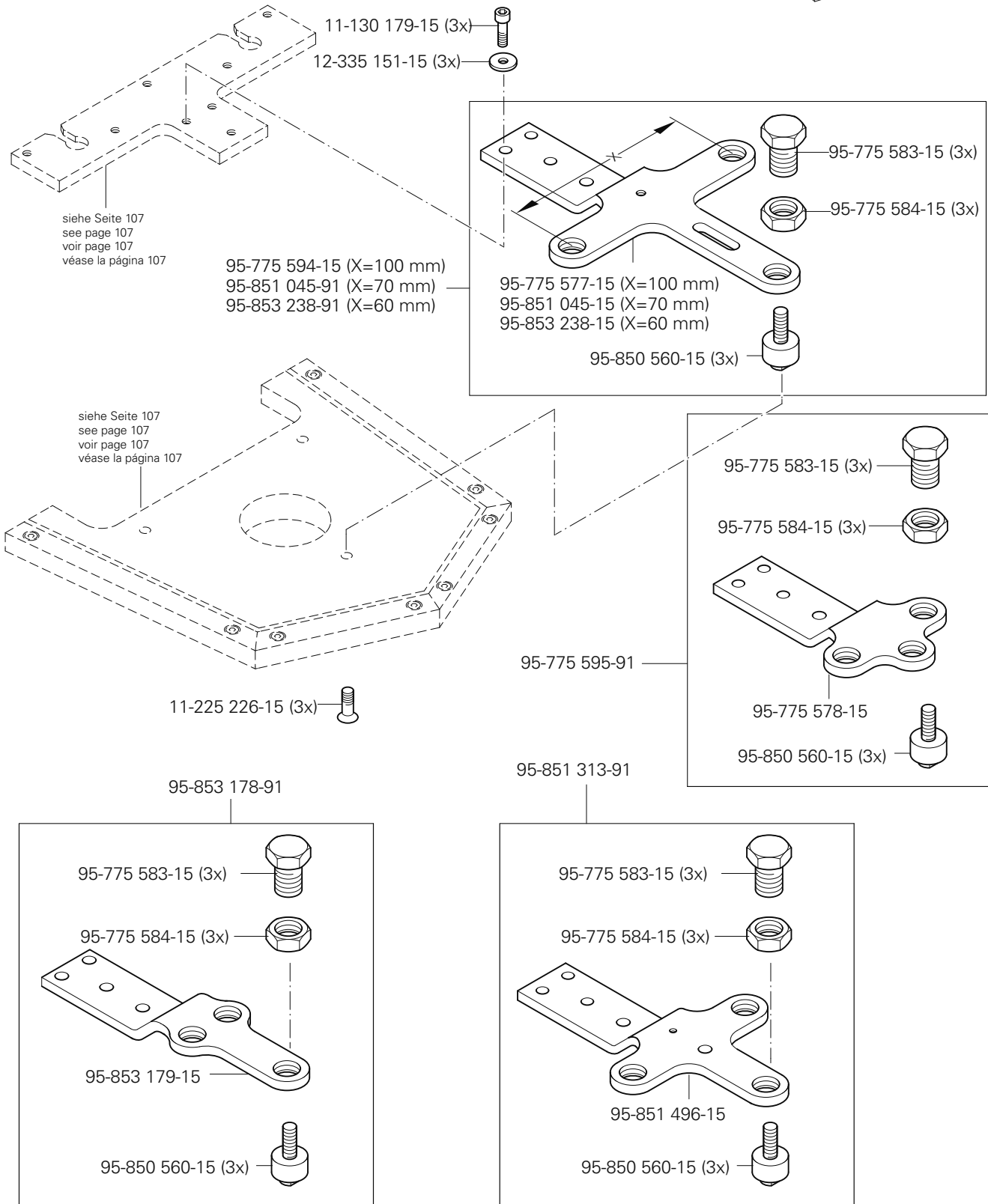
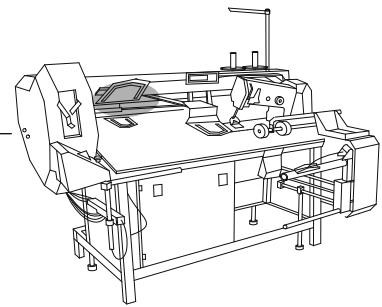

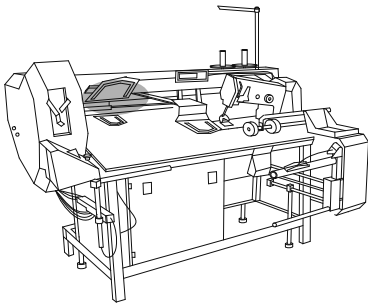

Teilesatz für Etiketten

Part set for labels

Jeu de pièces pour les étiquettes

Juego de piezas para etiquetas

PFAFF 3588-05/020

PFAFF 3588-15/020

16.10

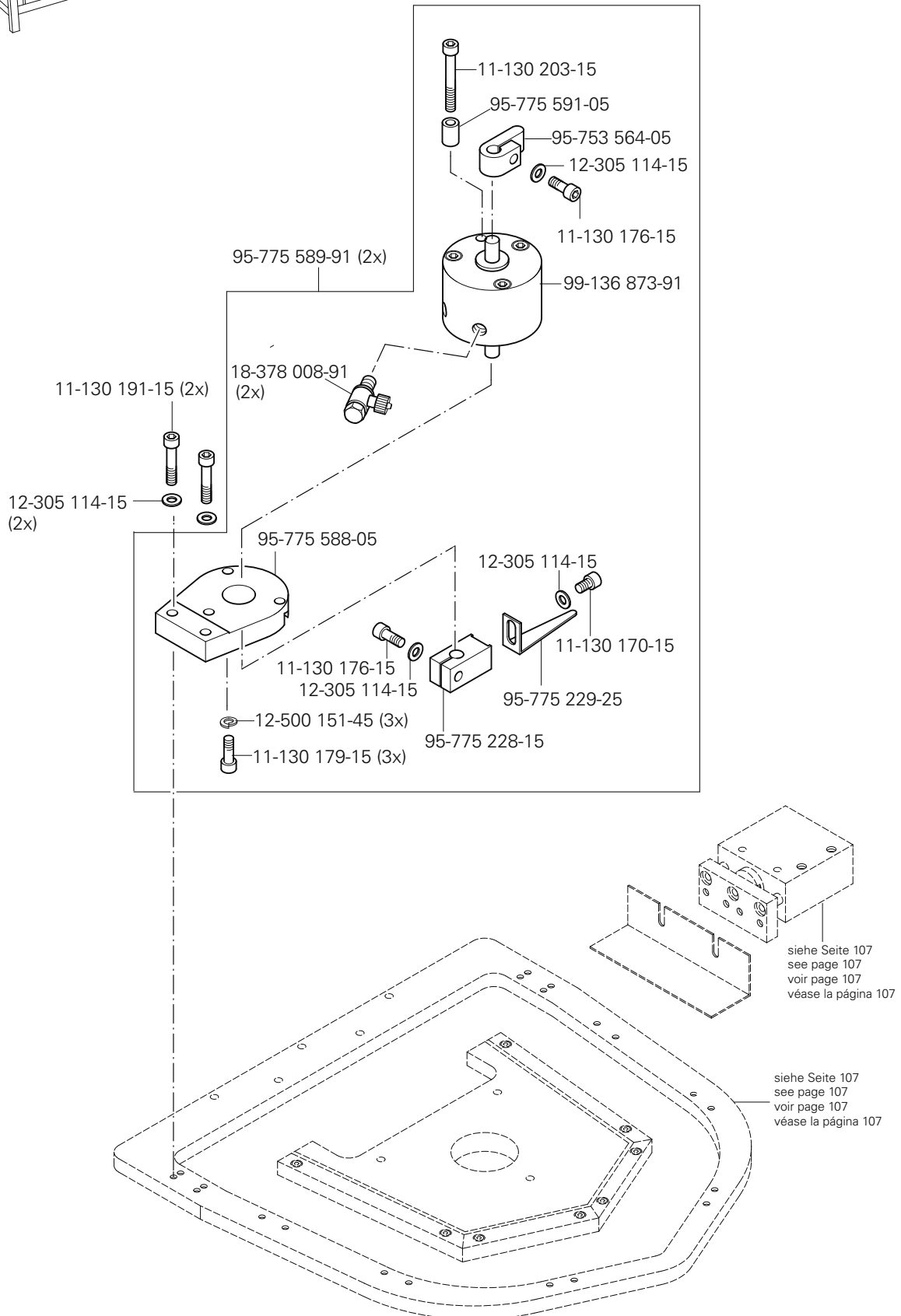

16.10

Teilesatz für Etiketten
 Part set for labels
 Jeu de pièces pour les étiquettes
 Juego de piezas para etiquetas

PFAFF 3588-05/020
 PFAFF 3588-15/020

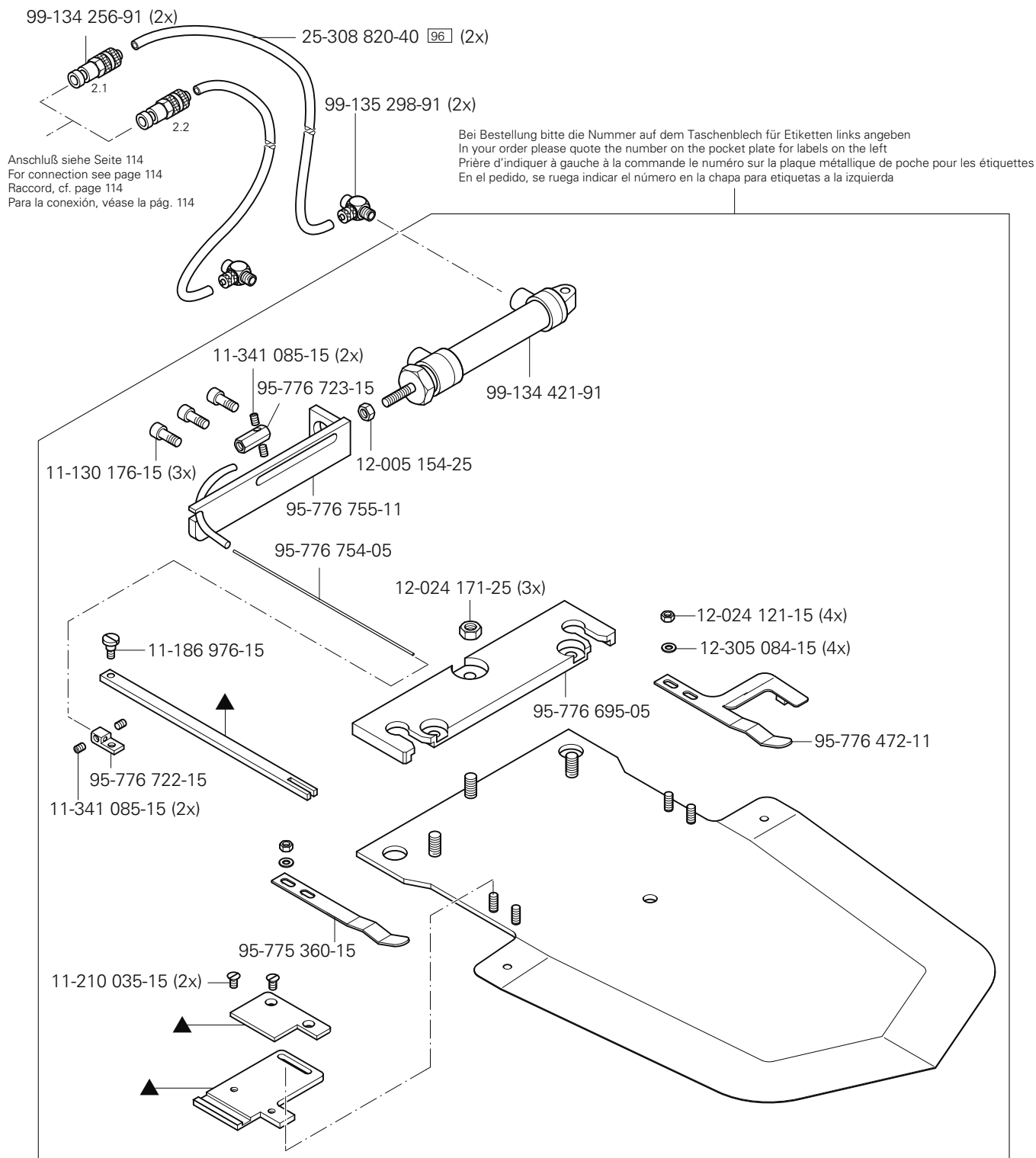
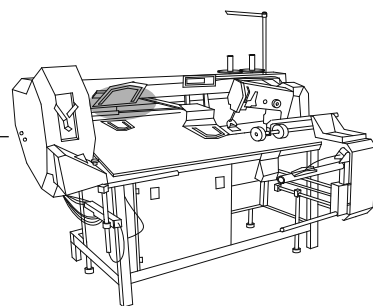

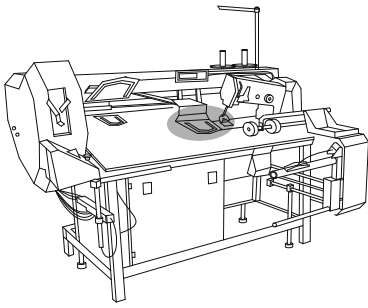

Teilesatz für Etiketten

Part set for labels

Jeu de pièces pour les étiquettes

Juego de piezas para etiquetas

PFAFF 3588-05/020

PFAFF 3588-15/020

16.10

99-134 256-91 (2x)

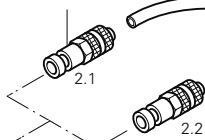

Anschluß siehe Seite 114
For connection see page 114
Raccord, cf. page 114
Para la conexión, véase la pág. 114

25-308 820-40  (2x)

99-135 298-91 (2x)

Bei Bestellung bitte die Nummer auf dem Taschenblech für Etiketten rechts angeben
In your order please quote the number on the pocket plate for labels on the right
Prière d'indiquer à droite à la commande le numéro sur la plaque métallique de poche pour les étiquettes
En el pedido, se ruega indicar el número en la chapa para etiquetas a la derecha

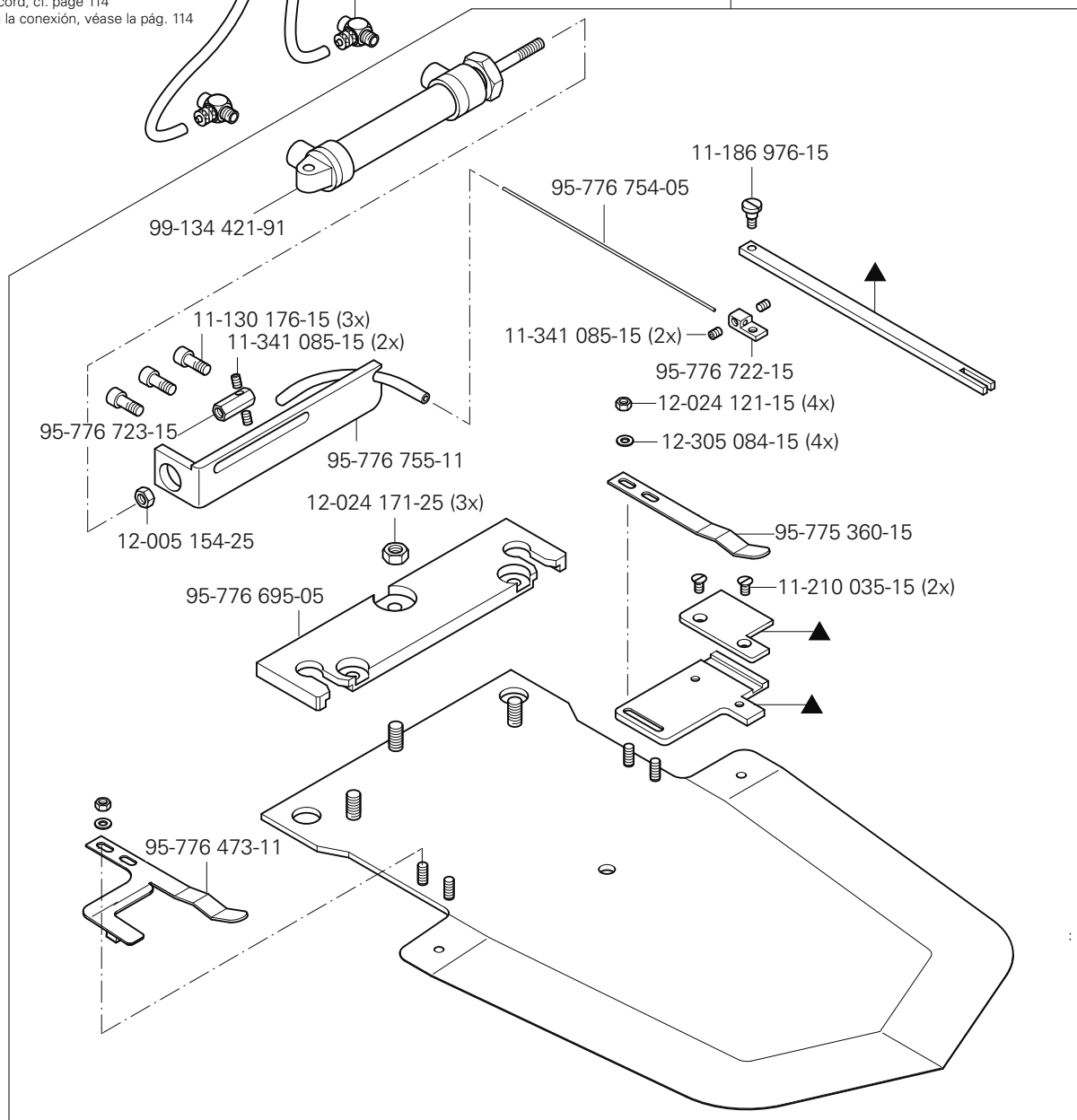

16.10

Teilesatz für Etiketten
 Part set for labels
 Jeu de pièces pour les étiquettes
 Juego de piezas para etiquetas

PFAFF 3588-05/020
 PFAFF 3588-15/020

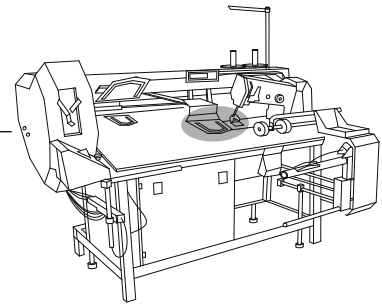

Anschluß siehe Seite 112 und 113
 For connection see page 112 and 113
 Raccord, cf. page 112 et 113
 Para la conexión, véase la pág. 112 y 113

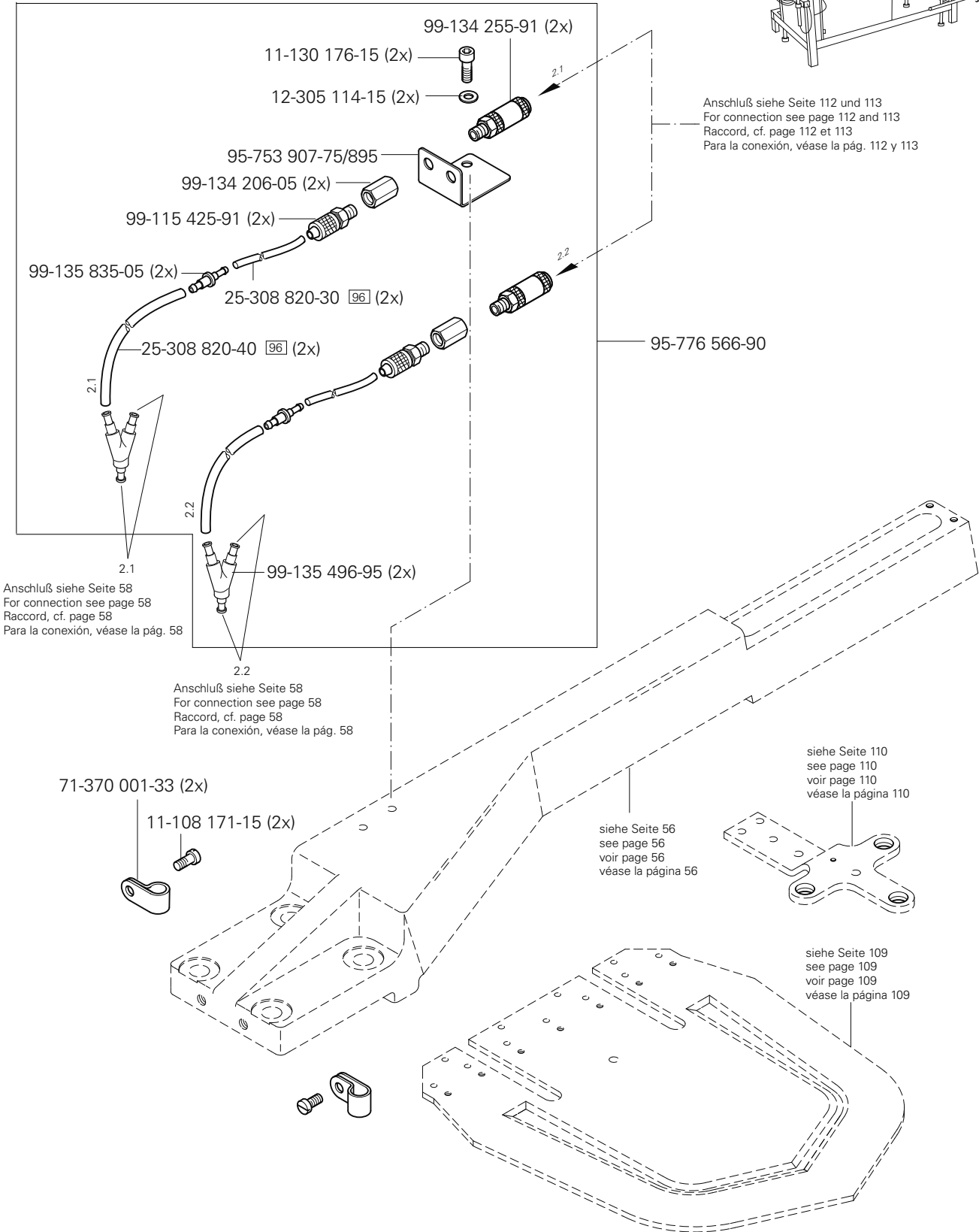

2.1
 Anschluß siehe Seite 58
 For connection see page 58
 Raccord, cf. page 58
 Para la conexión, véase la pág. 58

2.2
 Anschluß siehe Seite 58
 For connection see page 58
 Raccord, cf. page 58
 Para la conexión, véase la pág. 58

siehe Seite 56
 see page 56
 voir page 56
 véase la página 56

siehe Seite 110
 see page 110
 voir page 110
 véase la página 110

siehe Seite 109
 see page 109
 voir page 109
 véase la página 109

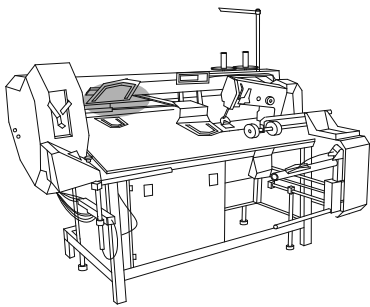

Teilesatz für Multisize

Multi-size part set

Jeu de pièces pour multi-taille

Juego de piezas para tallas múltiples

PFAFF 3588-05/020

PFAFF 3588-15/020

16.11

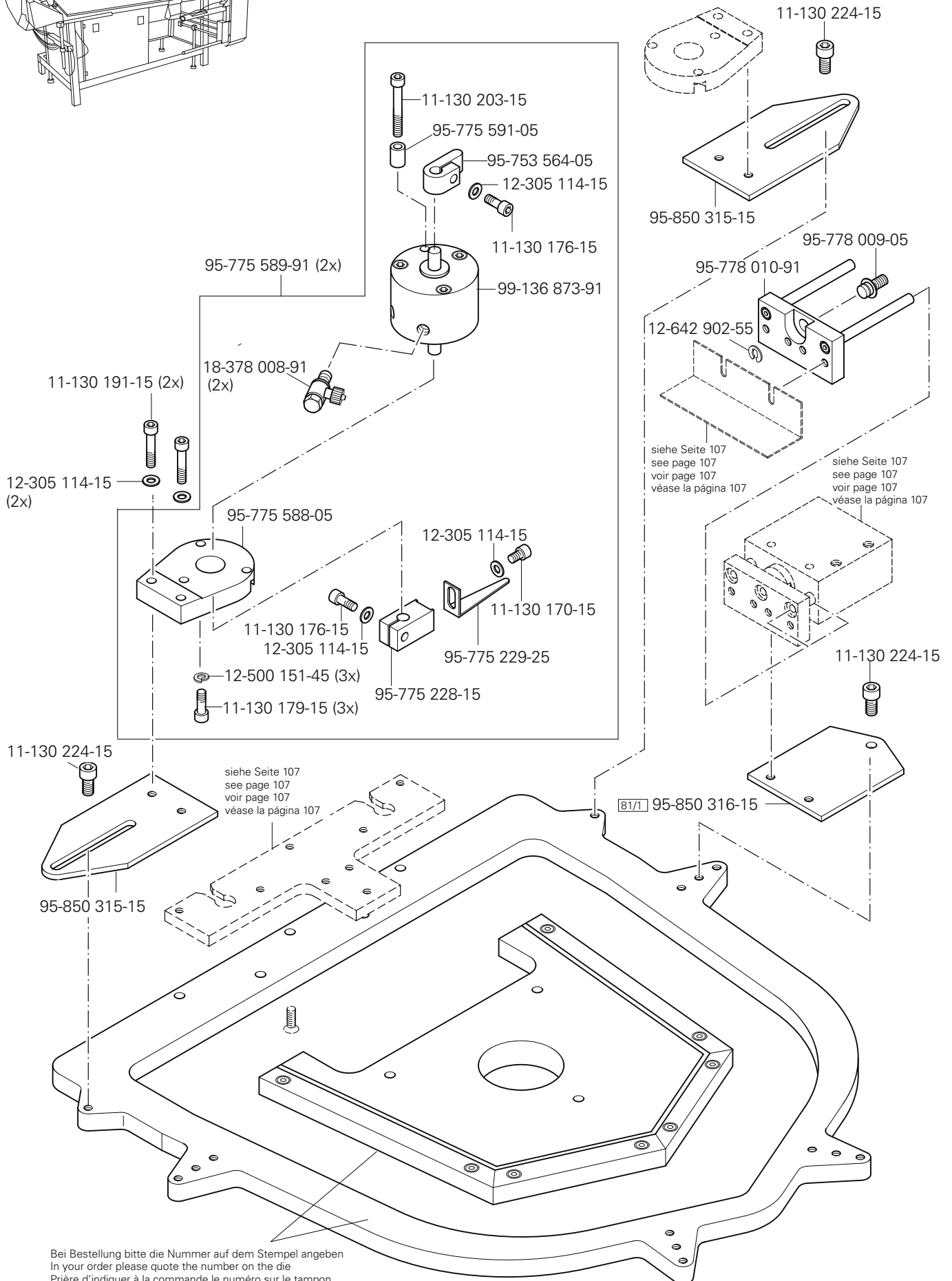

Bei Bestellung bitte die Nummer auf dem Stempel angeben
In your order please quote the number on the die
Prière d'indiquer à la commande le numéro sur le tampon
En el pedido, se ruega indicar el número en el sello.

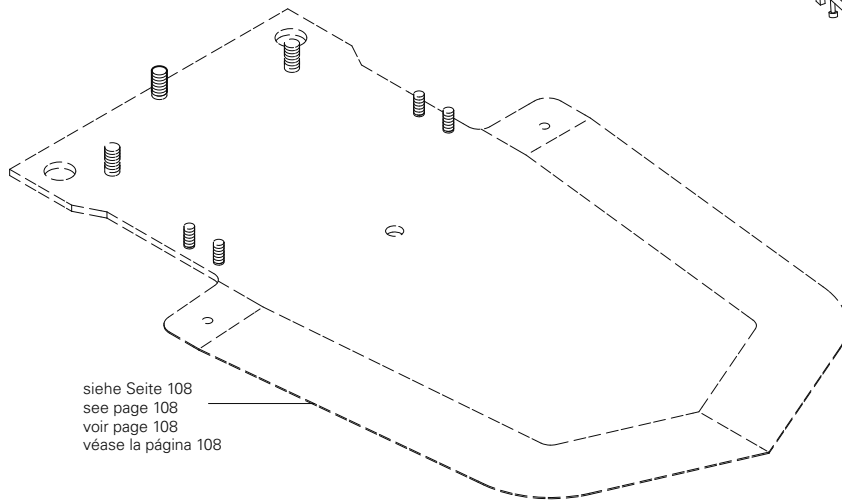
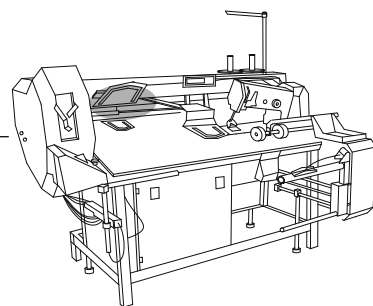

siehe Seite 108
 see page 108
 voir page 108
 véase la página 108

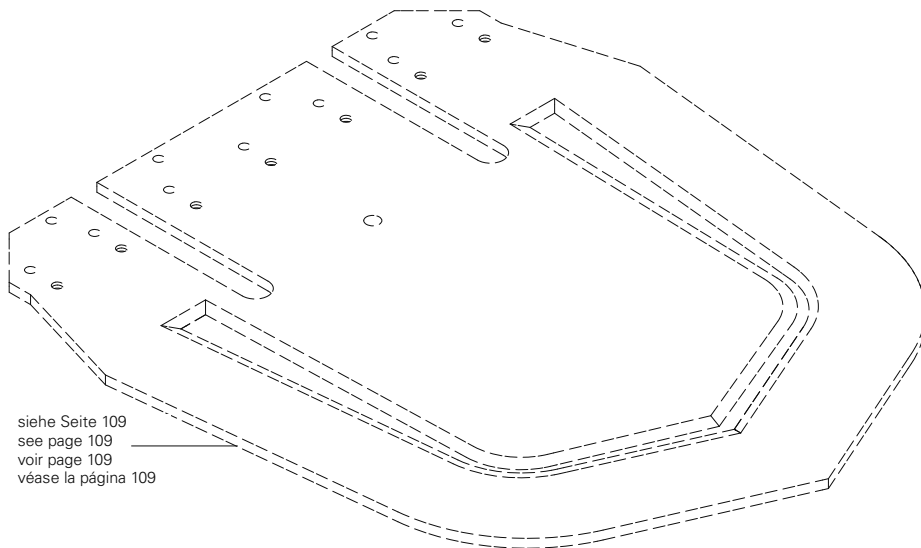

siehe Seite 109
 see page 109
 voir page 109
 véase la página 109

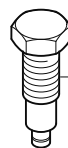

95-852 436-15



95-775 584-15

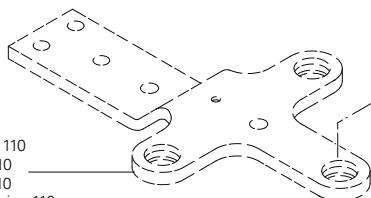

siehe Seite 110
 see page 110
 voir page 110
 véase la página 110



95-851 084-15



12-642 901-55

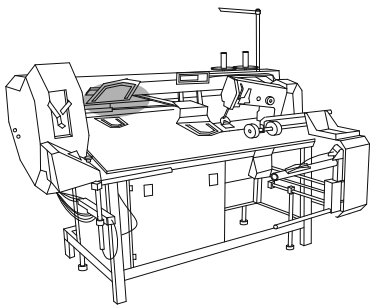

Teilesatz für Patten
 Part set for flaps
 Jeu de pièces pour pattes
 Juego de piezas para solapas de bolsillo

PFAFF 3588-05/020
 PFAFF 3588-15/020

16.12

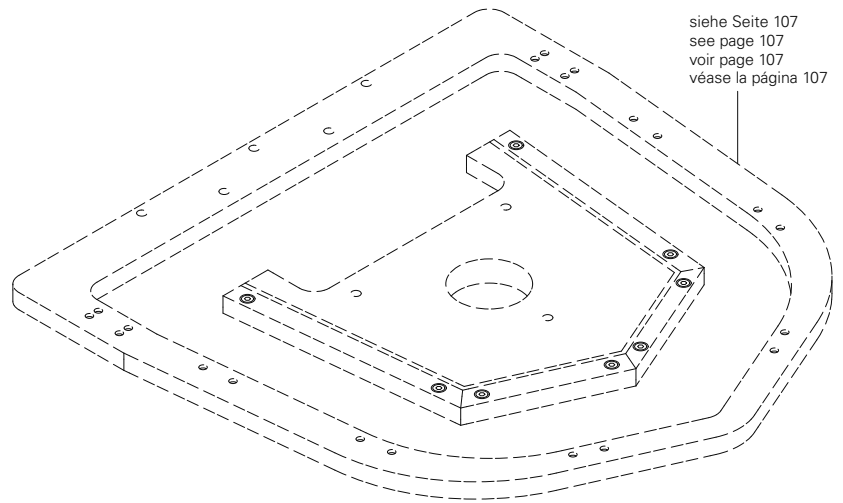

siehe Seite 107
 see page 107
 voir page 107
 véase la página 107

Bei Bestellung bitte die Nummer auf dem Taschenblech angeben
 In your order please quote the number on the pocket plate
 Prière d'indiquer à la commande le numéro sur la plaque métallique de poche
 En el pedido, se ruega indicar el número en la chapa de bolsillo.

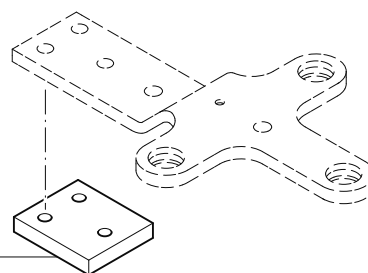
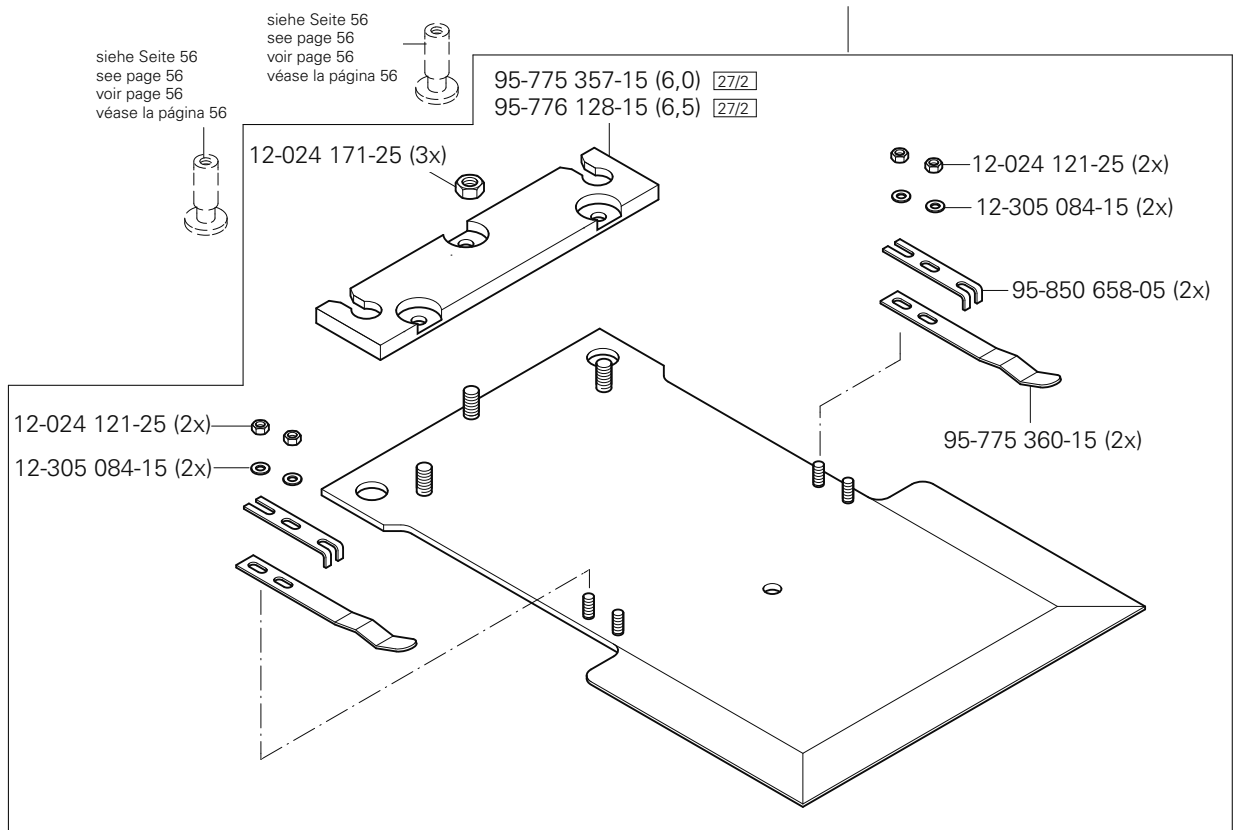

95-776 429-05

siehe Seite 110
 see page 110
 voir page 110
 véase la página 110

16.12

Teilesatz für Patten

Part set for flaps

Jeu de pièces pour pattes

Juego de piezas para solapas de bolsillo

PFAFF 3588-05/020

PFAFF 3588-15/020

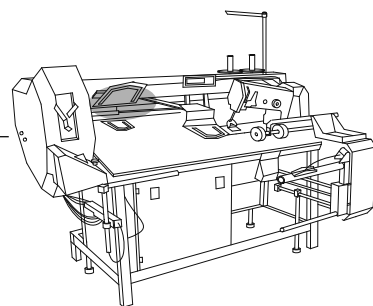

Anschluß siehe Seite 120
For connection see page 120
Raccord, cf. page 120
Para la conexión, véase la pág.120

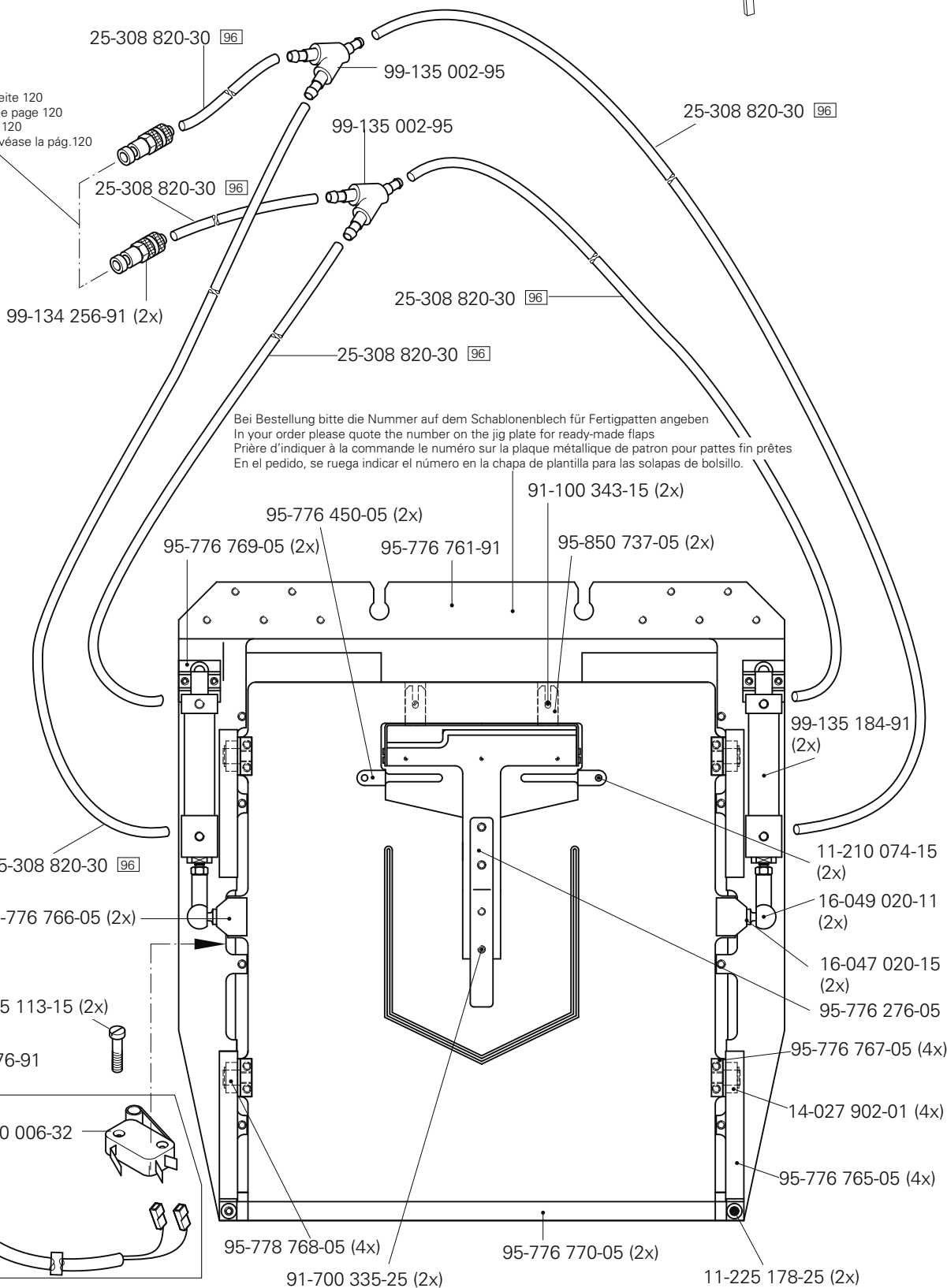

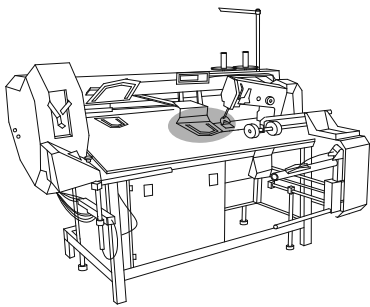

Teilesatz für Patten

Part set for flaps

Jeu de pièces pour pattes

Juego de piezas para solapas de bolsillo

PFAFF 3588-05/020

PFAFF 3588-15/020

16.12

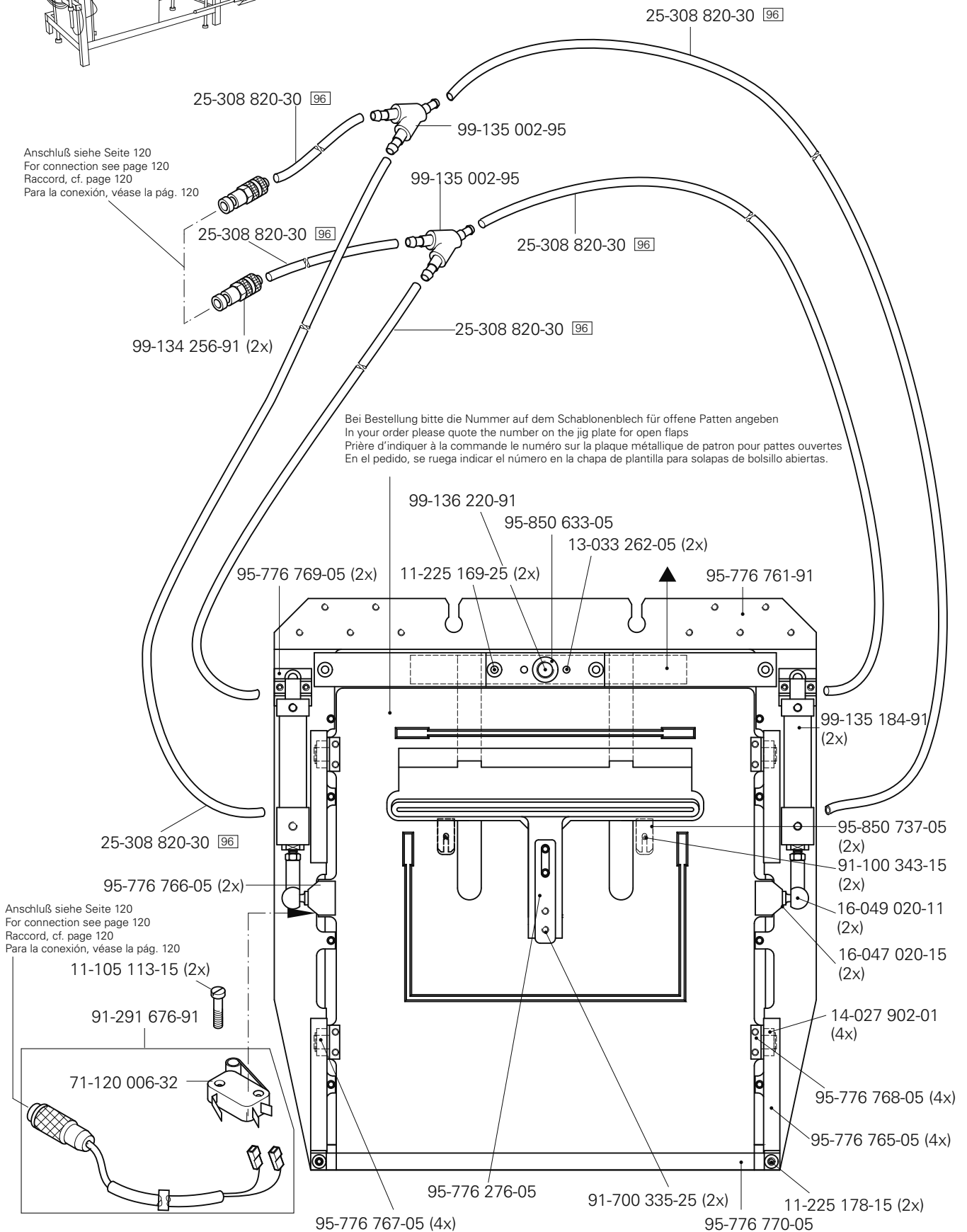

16.12

Teilesatz für Patten

Part set for flaps

Jeu de pièces pour pattes

Juego de piezas para solapas de bolsillo

PFAFF 3588-05/020

PFAFF 3588-15/020

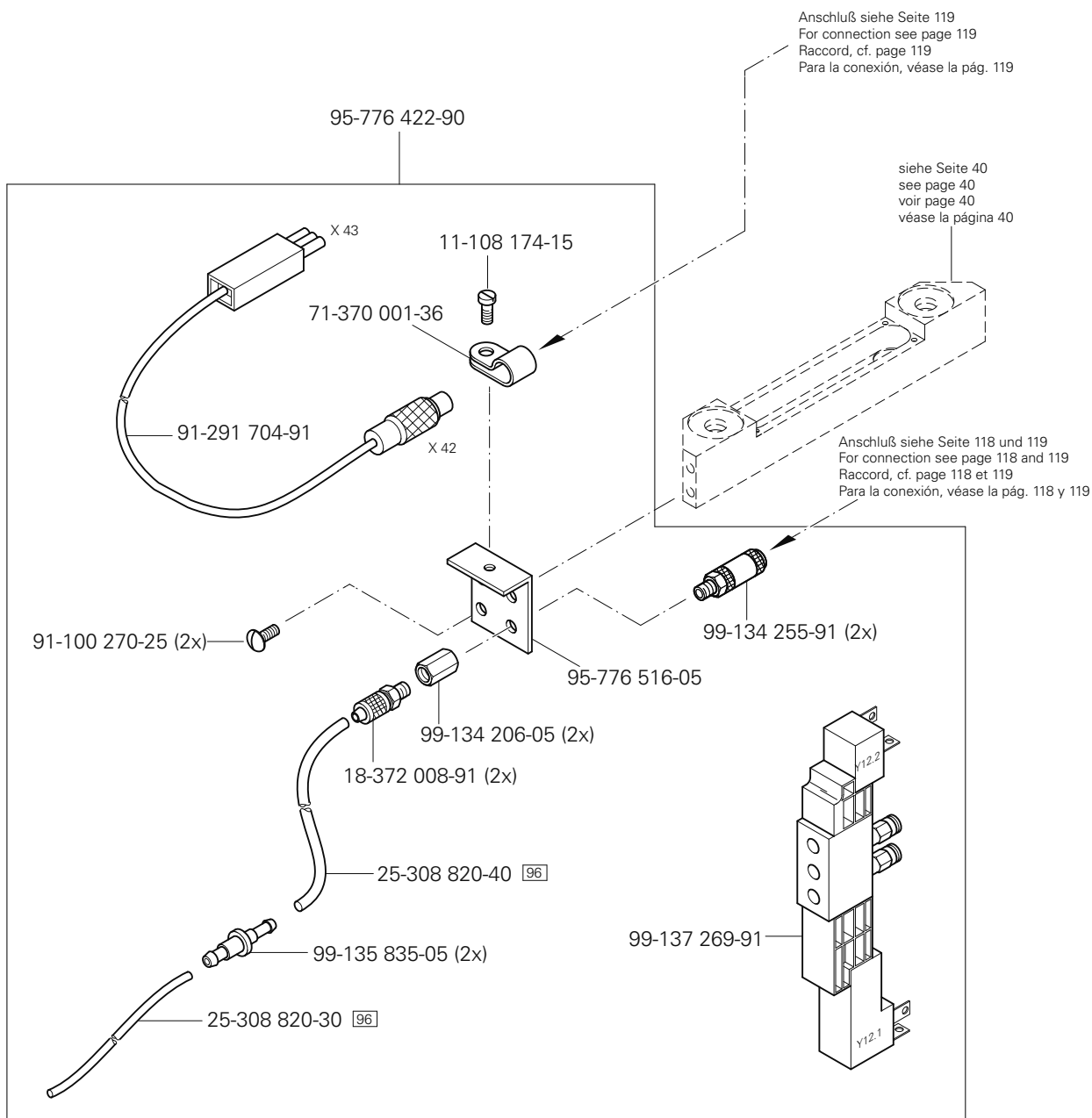
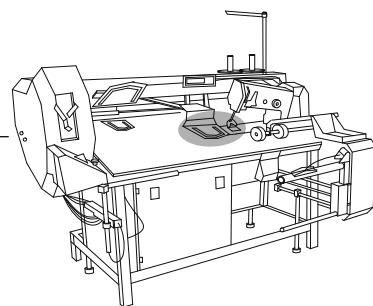

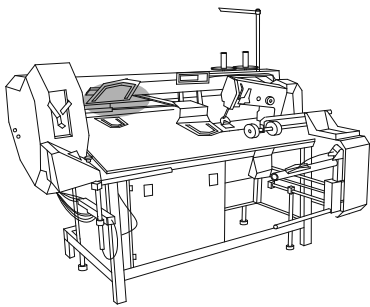

Teilesatz für variablen Nähsschlitz
 Part set for variable sewing slot
 Jeu de pièces pour fente variable de couture
 Juego de piezas para ranura variable de costura

PFAFF 3588-05/020
 PFAFF 3588-15/020

16.13

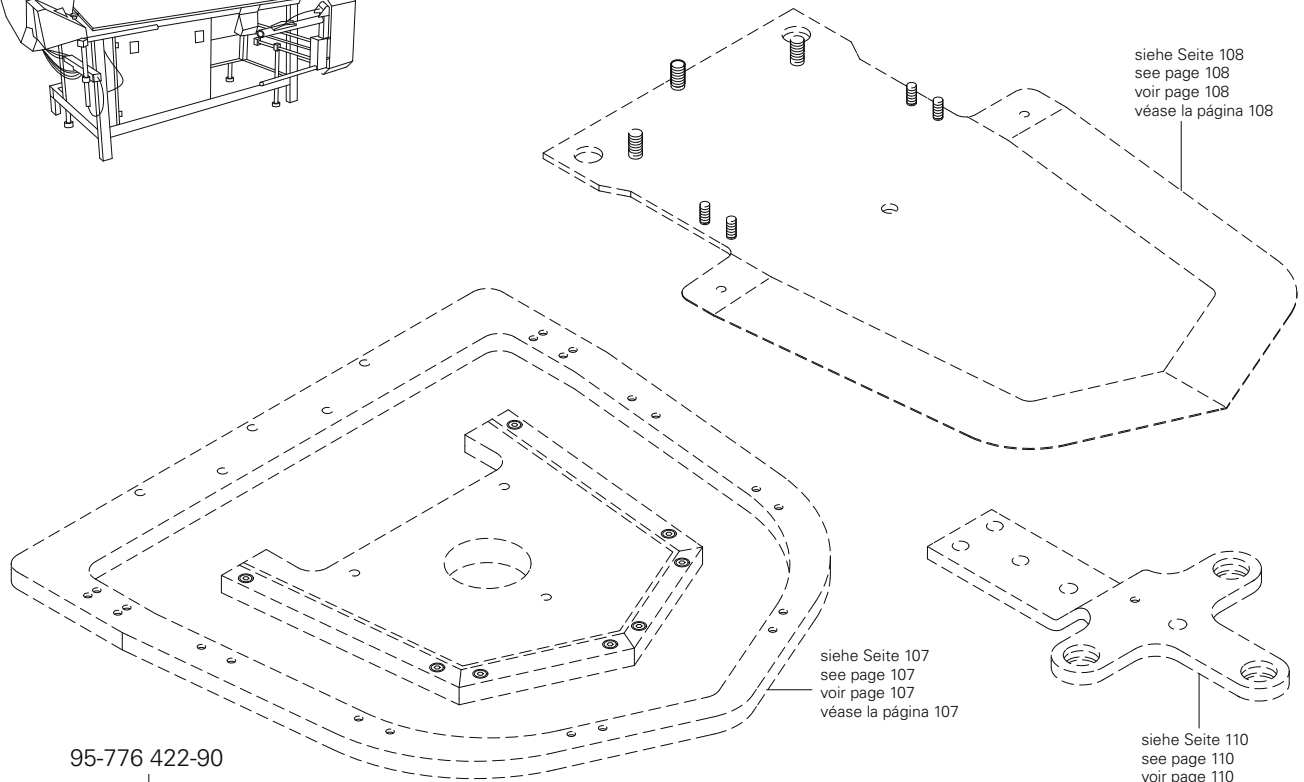

95-776 422-90

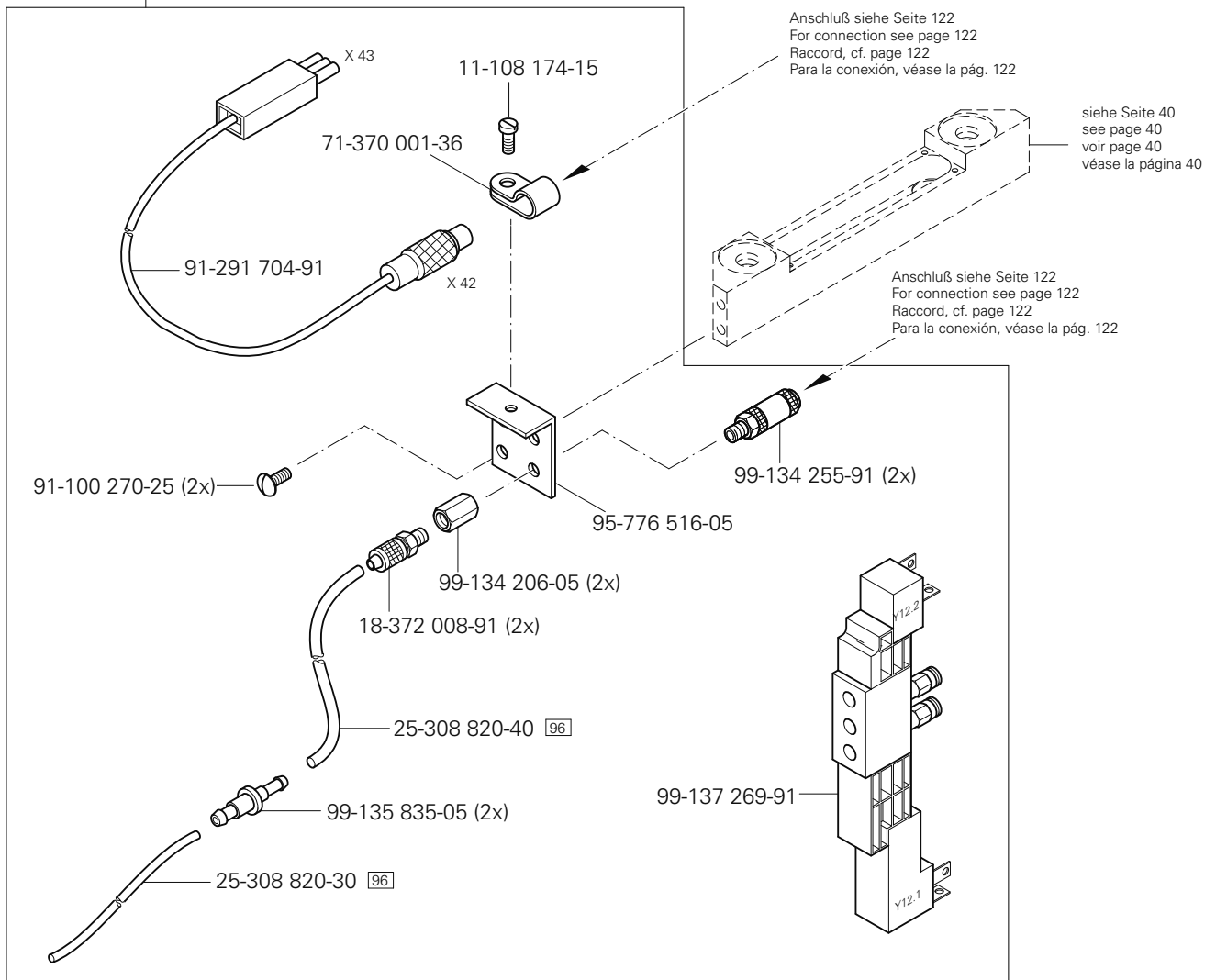

16.13

Teilesatz für variablen Nähschlitz

Part set for variable sewing slot

Jeu de pièces pour fente variable de couture

Juego de piezas para ranura variable de costura

PFAFF 3588-05/020

PFAFF 3588-15/020

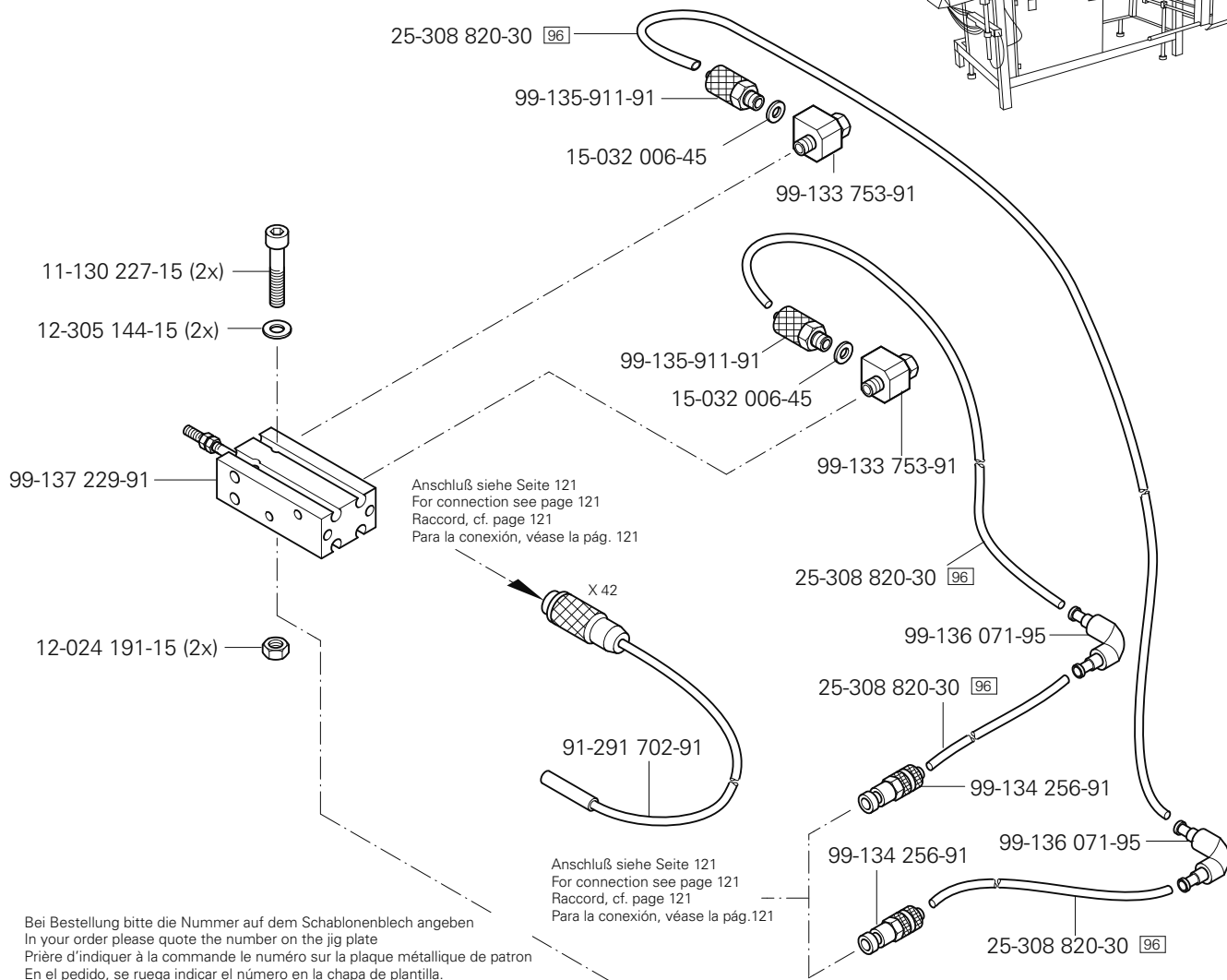
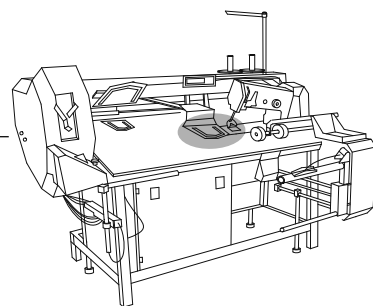

11-130 224-15 (2x)
 12-305 144-15 (2x)

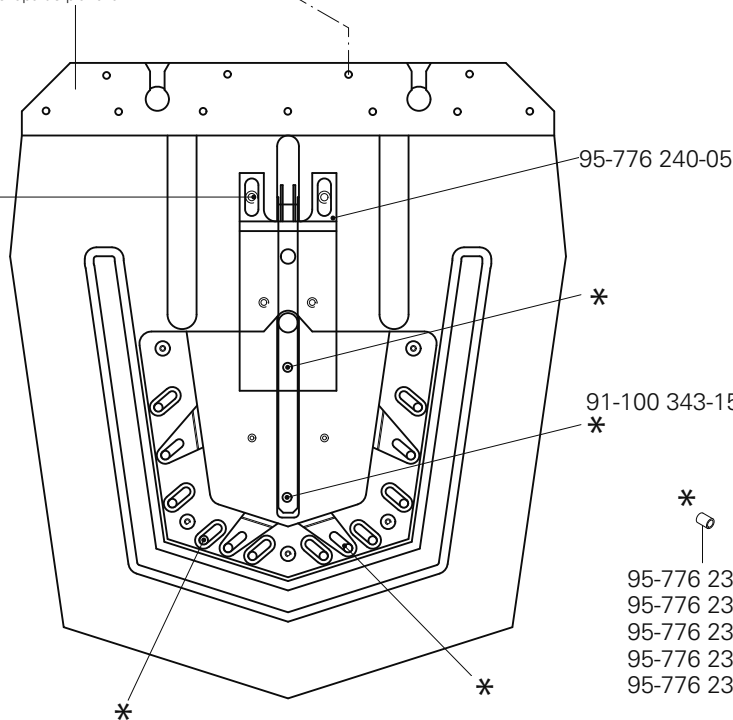

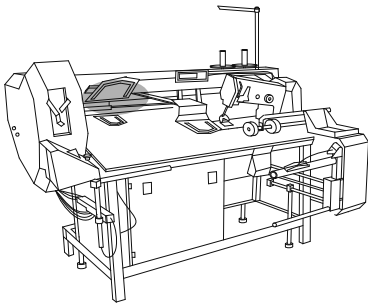

Anbausatz für vorgebuggte Taschen
 Add-on kit pro-folded-pockets
 Kit pour poches-conformées
 JConjunto de piezas para bolsillo predoblado

PFAFF 3588-05/020
 PFAFF 3588-15/020

16.14

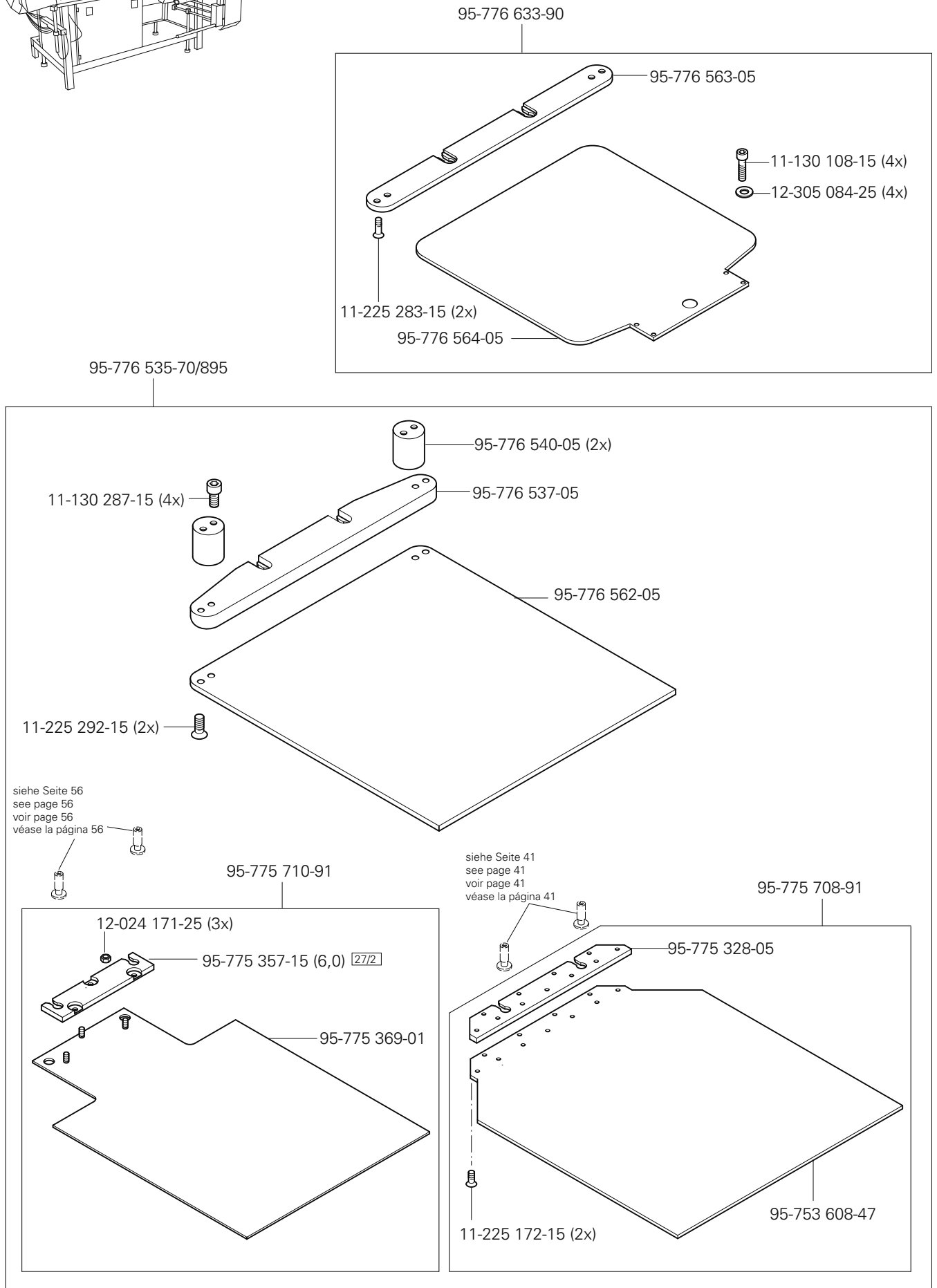

16.15

Anbausatz für Cargotaschenabweiser
 Add-on kit for cargo pocket deflector
 Kit pour déviateur poche cargo
 Kit para desviador do bolsillo de fuelle

PFAFF 3588-05/020
 PFAFF 3588-15/020

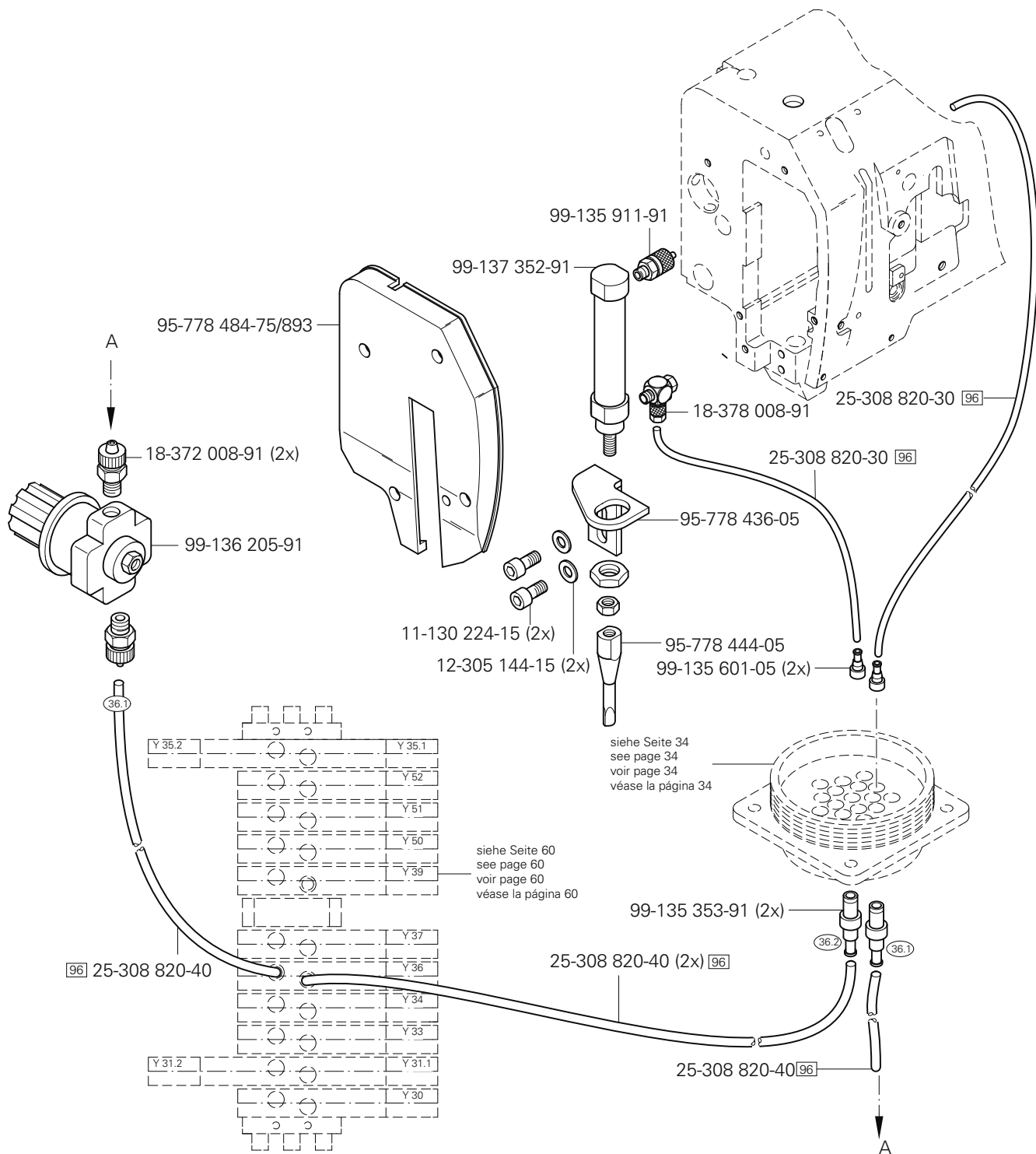
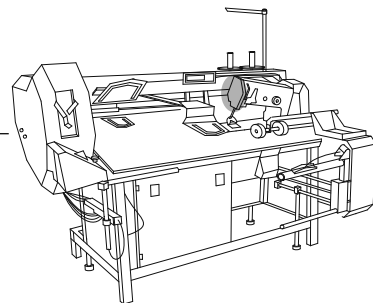

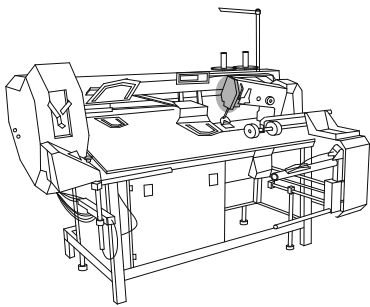

Anbausatz für Cargotaschenabweiser
 Add-on kit for cargo pocket deflector
 Kit pour déviateur poche cargo
 Kit para desviador do bolsillo de fuelle

PFAFF 3588-05/020
 PFAFF 3588-15/020

16.15

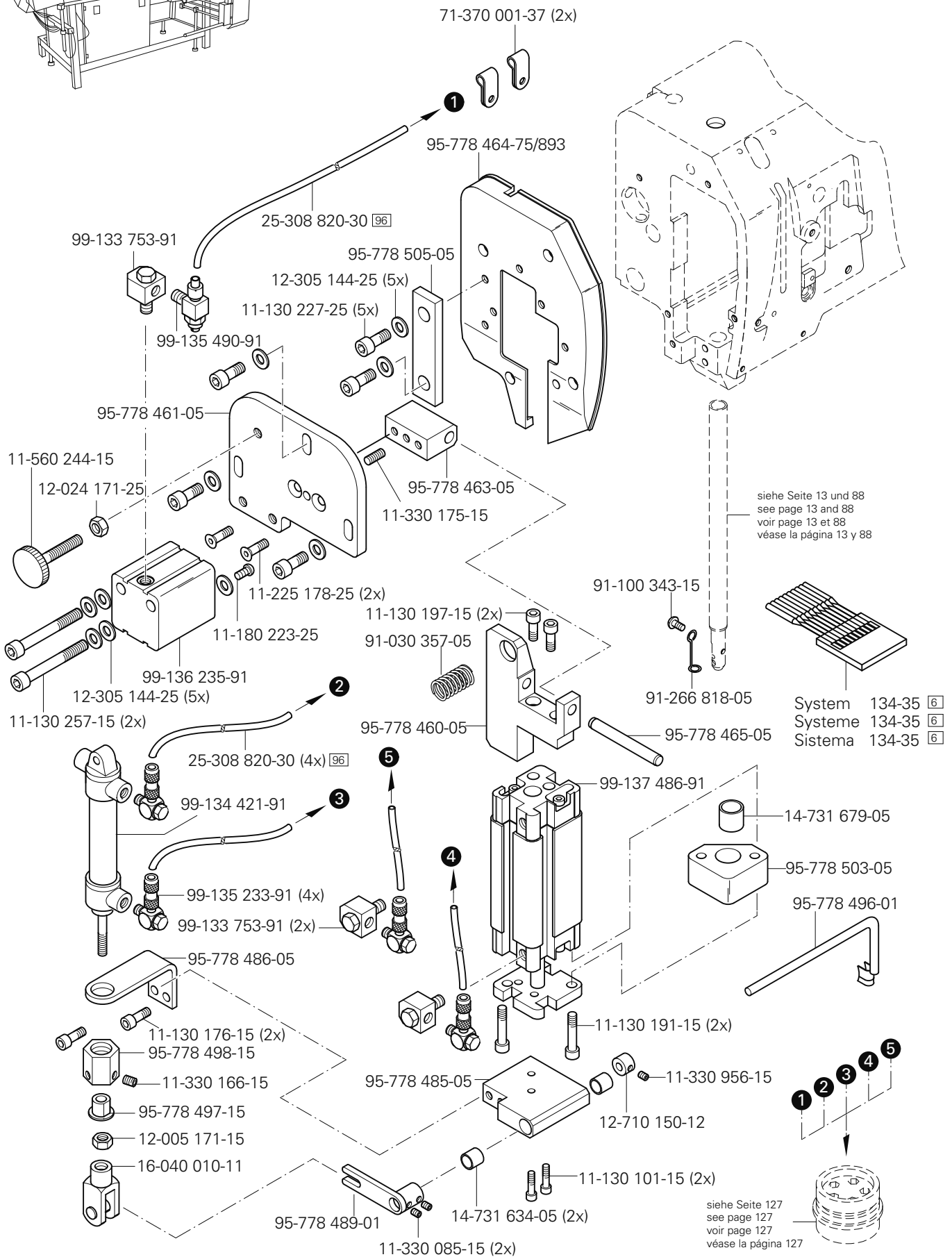

16.15

Anbausatz für Cargotaschenabweiser
Add-on kit for cargo pocket deflector
Kit pour déviateur poche cargo
Kit para desviador do bolsillo de fuelle

PFAFF 3588-05/020
PFAFF 3588-15/020

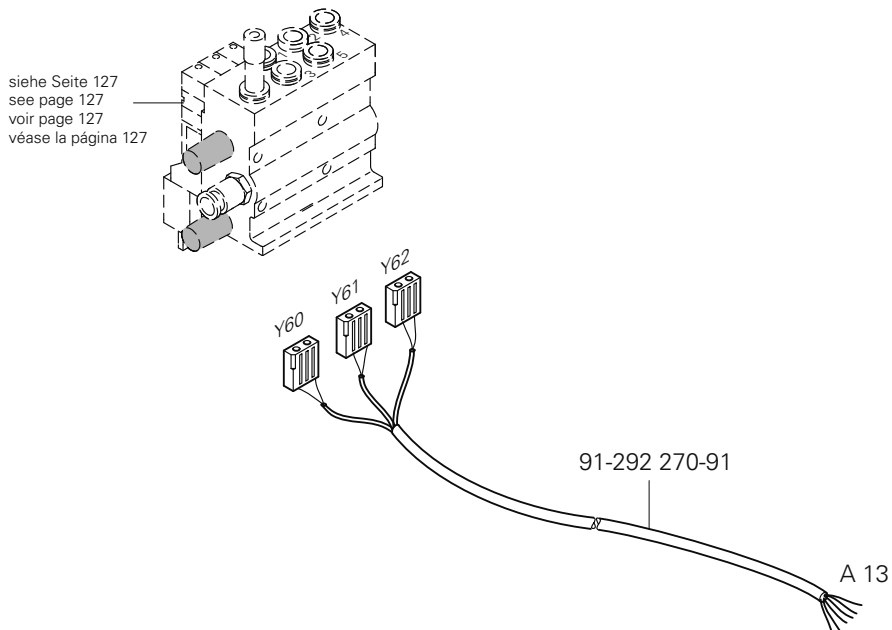
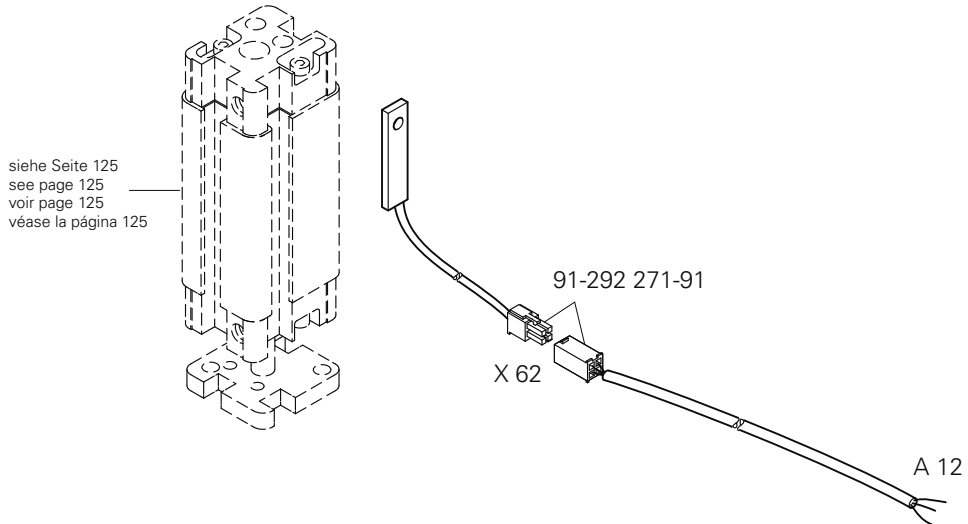
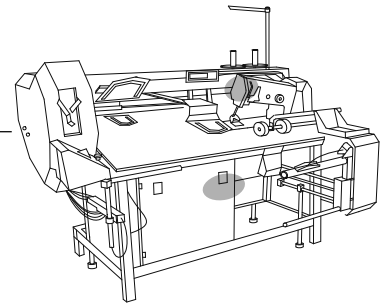

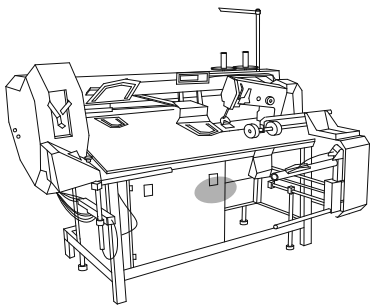

Anbausatz für Cargotaschenabweiser
 Add-on kit for cargo pocket deflector
 Kit pour déviateur poche cargo
 Kit para desviador do bolsillo de fuelle

PFAFF 3588-05/020
 PFAFF 3588-15/020

16.15

Anschluß siehe Seite 125
 For connection see page 125
 Raccord, cf. page 125
 Para la conexión, véase la pág. 125

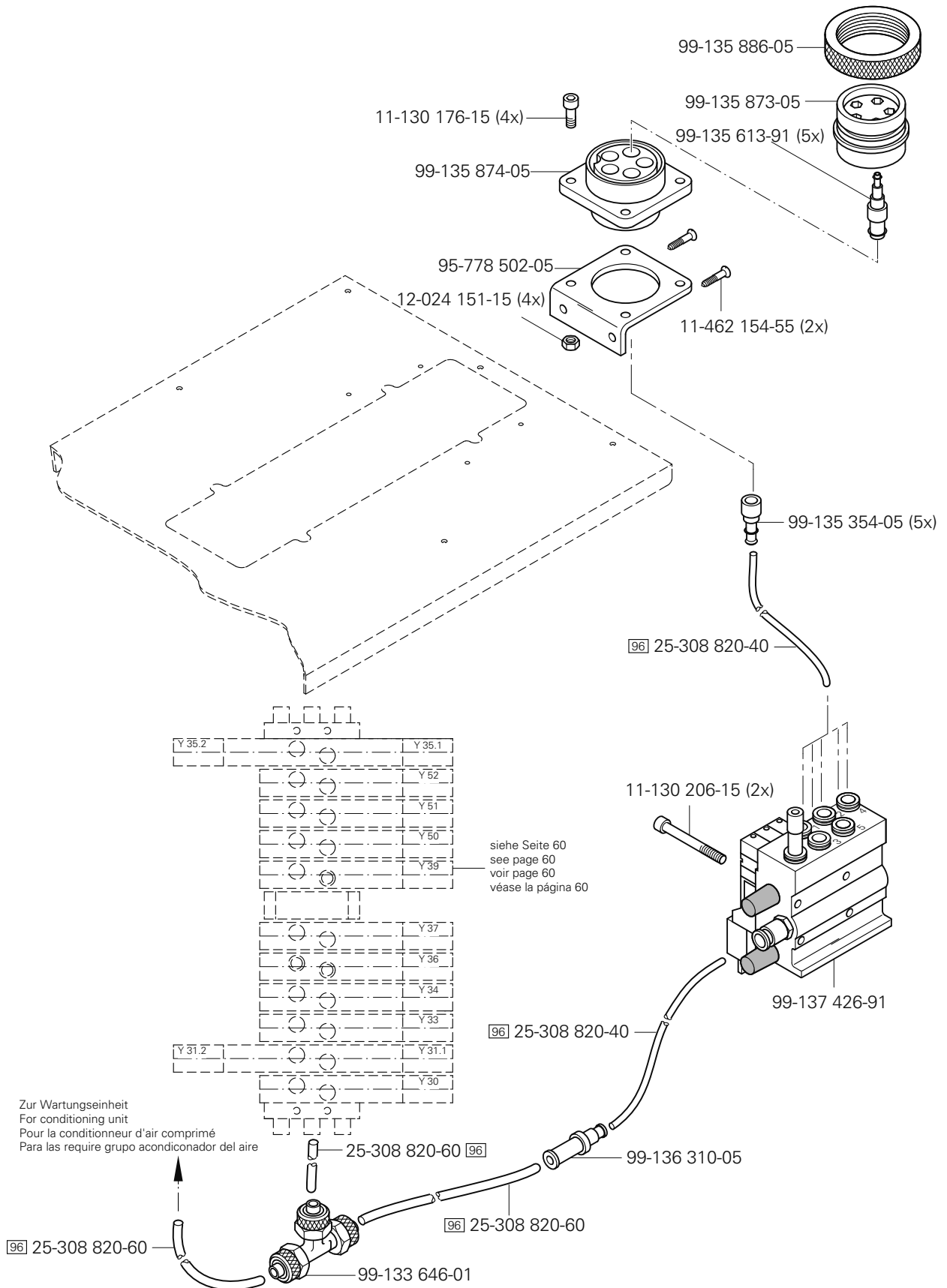

16.15

Anbausatz für Cargotaschenabweiser
 Add-on kit for cargo pocket deflector
 Kit pour déviateur poche cargo
 Kit para desviador do bolsillo de fuelle

PFAFF 3588-05/020
 PFAFF 3588-15/020

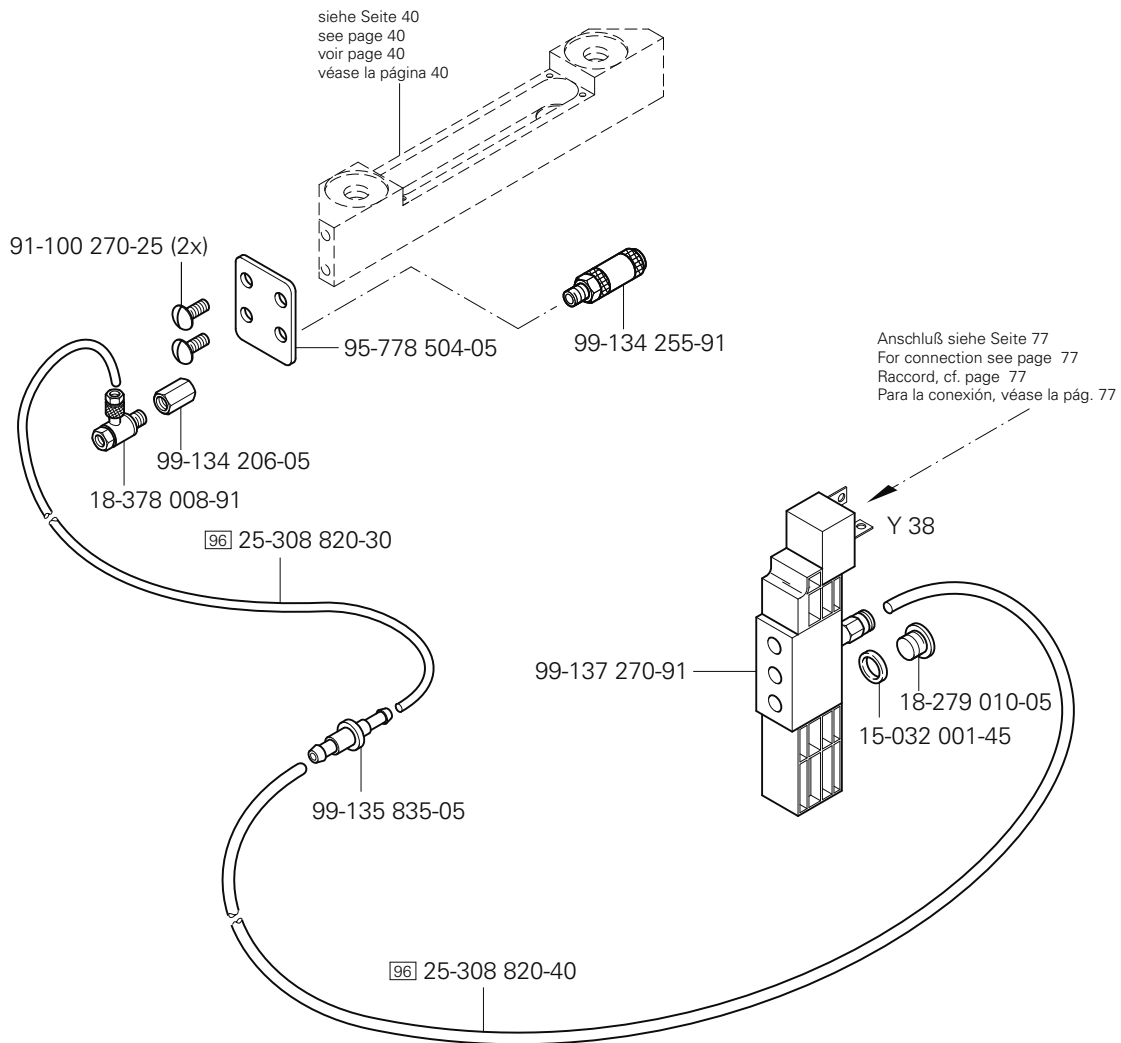
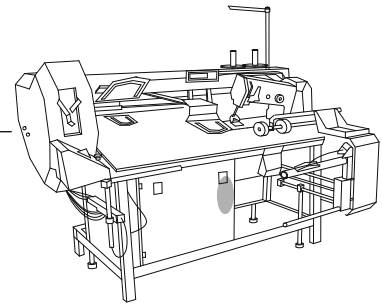

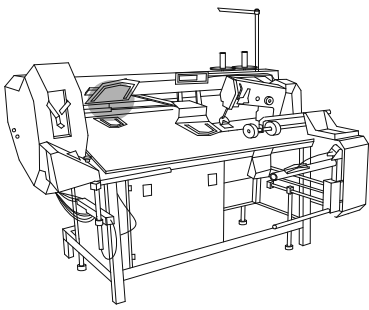

Adapter für Teilesätze der PFAFF 3568
 Gauge parts adapter for the PFAFF 3568
 Adapteur de kits pour la PFAFF 3568
 Adaptador para jurgos de piezas de la PFAFF 3568

16.16

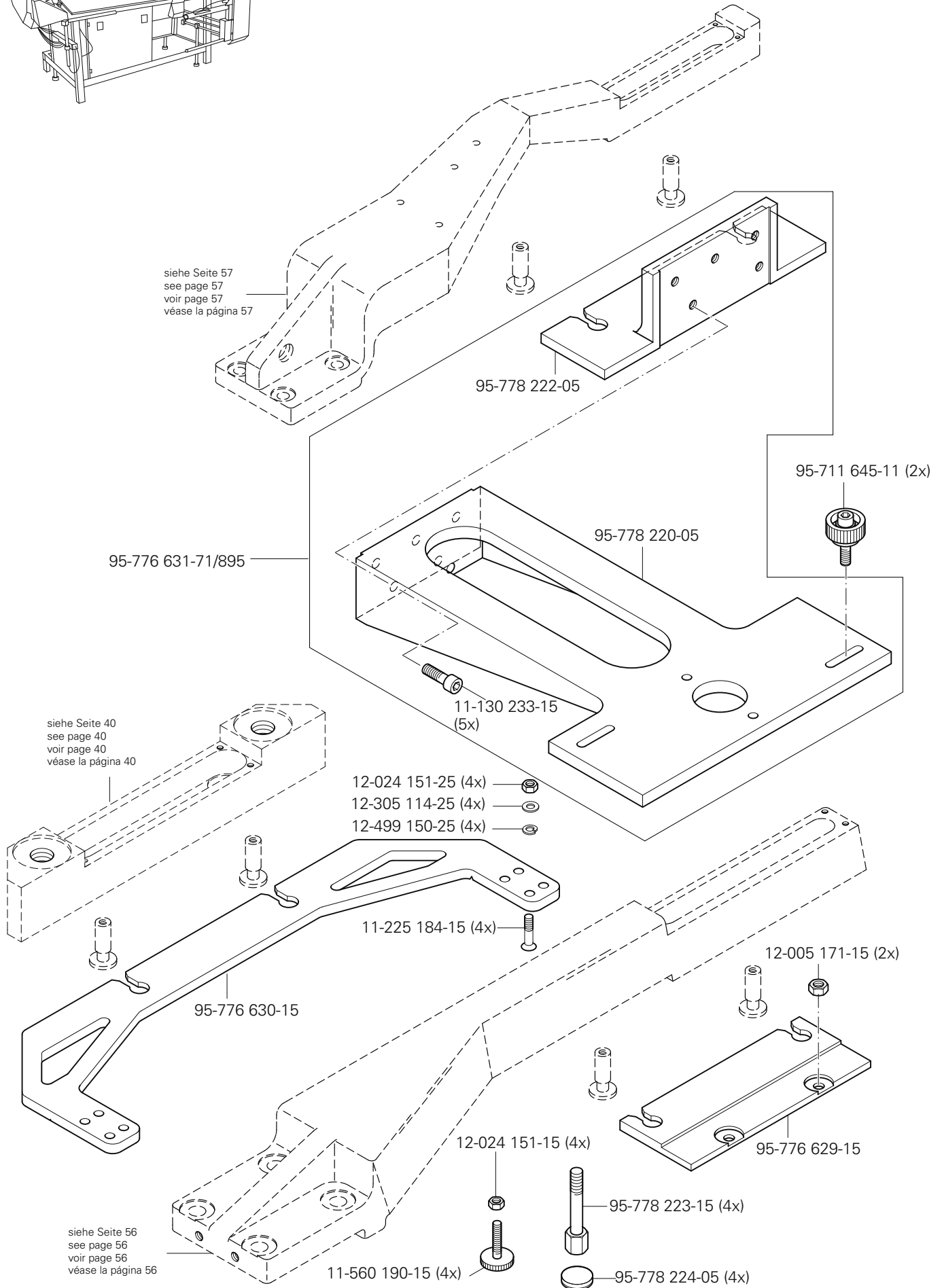

No.	Seite Page Pages Página	No.	Seite Page Pages Página	No.	Seite Page Pages Página	No.	Seite Page Pages Página
11-032 402-15	37	11-130 089-15	14	11-130 251-15	19, 32, 51	11-130 470-15	90
11-032 582-15	101	11-130 092-15	28	11-130 257-15	125	1-130 482-15	47
11-039 179-15	40, 91	11-130 095-15	28	11-130 257-25	62	11-130 494-15	90
11-039 225-15	13	11-130 097-15	40, 92, 102	11-130 281-15	14	11-130 533-15	64, 90
11-039 228-15	56, 91	11-130 101-15	40, 125	11-130 284-15	33, 101	11-130 551-15	47
11-039 231-15	52	11-130 108-15	44, 123	11-130 284-25	71	11-130 557-15	51
11-039 240-15	32	11-130 113-15	97	11-130 287-15	11, 19, 29, 37, 50, 123	11-130 719-15	47, 49
11-039 291-15	56	11-130 170-15	13, 107, 111, 115	11-130 293-15	22, 27, 32, 37, 49, 51, 66, 97, 100	11-130 903-15	22
11-039 306-15	28	11-130 173-15	28, 33, 34, 41, 56, 57, 65, 106	11-130 293-25	41, 56, 57, 103	11-130 905-15	21
11-039 318-15	55	11-130 176-15	21, 57, 78, 99, 107, 109, 111, 112, 113, 114, 115, 125, 127	11-130 296-15	99	11-130 906-15	19, 47, 78
11-039 354-15	75	11-130 179-15	25, 40, 49, 78, 91, 96, 97, 110, 111, 115	11-130 299-15	49, 53	11-130 915-55	55
11-039 378-15	65	11-130 191-15	49, 106, 111, 115, 125	11-130 299-25	73	11-132 169-15	14
11-039 459-15	43, 44	11-130 197-15	98, 125	11-130 305-15	52, 55	11-132 172-15	29
11-039 749-15	11	11-130 203-15	111, 115	11-130 311-15	99	11-132 220-15	52
11-105 275-25	55	11-130 206-15	106, 107, 127	11-130 323-15	38	11-132 223-15	29
11-105 113-15	118, 119	11-130 209-15	58, 60, 107	11-130 332-15	47	11-132 286-15	45
11-108 093-25	75	11-130 224-15	15, 26, 32, 38, 40, 90, 91, 105, 115, 122, 124	11-130 332-15	47	11-132 352-15	11
11-108 099-25	68, 76	11-130 224-25	82	11-130 341-15	90, 95, 105	11-172 127-25	14
11-108 108-15	20	11-130 227-15	45, 49, 94, 95, 122	11-130 353-15	67	11-173 171-15	51, 55
11-108 120-25	14	11-130 227-25	82, 83, 125	11-130 359-15	67	11-173 171-25	71, 73, 75
11-108 171-15	28, 114	11-130 233-15	11, 38, 39, 40, 42, 45, 50, 57, 78, 91, 129	11-130 371-15	56, 57	11-173 177-15	12
11-108 174-15	26, 120, 121	11-130 239-15	11, 52	11-130 377-15	51, 70, 97	11-174 082-15	13, 88
11-108 177-25	80	11-130 239-25	81, 83	11-130 383-15	51	11-174 176-15	14
11-108 192-15	28	11-130 245-15	36, 40, 78, 89, 104	11-130 389-15	38	11-180 169-25	11, 14
11-108 219-15	30			11-130 389-15	38	11-180 175-25	14
11-108 225-15	11			11-130 395-15	49	11-180 223-25	14, 125
11-108 228-25	80			11-130 452-15	37, 43, 44, 96, 97	11-186 976-15	112, 113
11-108 234-15	22			11-130 458-15	55, 93	11-187 028-15	56
11-108 255-15	17			11-130 461-15	39, 42	11-210 035-15	112, 113
11-108 846-15	18			11-130 464-15	39, 42, 43, 44, 45, 51	11-210 038-15	29

Index (Teilenummern / Seitenzahlen)

Index (part numbers / page numbers)

Index (numéros de pièces, de pages)

Index (números de pieza / números de página)

PFAFF 3588-05/020
PFAFF 3588-15/020
17

No.	Seite Page Pages Página	No.	Seite Page Pages Página	No.	Seite Page Pages Página	No.	Seite Page Pages Página
11-210 044-25	13	11-225 292-15	123	11-335 085-15	41	12-024 151-15	50, 106, 127, 129
11-210 074-15	118	11-225 358-15	37, 40, 91	11-335 217-15	15	12-024 151-25	129
11-210 078-15	29	11-225 364-15	52	11-335 280-15	13	12-024 171-15	50, 78
11-210 078-25	25	11-225 457-15	43, 44	11-335 379-15	34	12-024 171-25	32, 35, 51, 82, 84, 86, 108,112, 113, 117, 123, 125
11-210 084-25	20	11-225 902-15	18	11-335 902-15	15, 31	12-024 191-15	27, 43, 44, 52, 55, 78, 99, 122
11-210 088-25	40, 56, 57, 91	11-225 904-05	64	11-341 085-15	112, 113	12-024 191-25	85, 90,105
11-210 165-15	73	11-250 084-25	16	11-341 166-15	29	12-024 211-15	37, 51, 99
11-210 165-25	26	11-317 971-15	18	11-341 169-15	40, 43, 44, 91	12-024 231-15	21, 43, 44, 99
11-210 168-15	27	11-330 082-15	79	11-341 217-15	18	12-024 251-15	37, 101
11-210 168-25	16	11-330 085-15	125	11-341 280-15	12	12-024 291-15	43, 44
11-210 169-15	22, 30	11-330 166-15	13, 17, 22, 33, 54, 125	11-341 901-15	27	12-024 291-25	11
11-210 169-25	69	11-330 169-15	14, 45	11-341 902-15	15	12-105 190-25	80
11-210 174-15	28	11-330 175-15	45, 125	11-341 905-15	15, 28, 29, 31	12-160 193-25	84
11-210 210-15	28	11-330 217-15	17, 25, 26, 29, 39, 42	11-460 193-15	78	12-305 084-15	40, 79, 92, 97, 102, 108, 112, 113,117 123
11-225 094-15	40	11-330 220-15	13, 17, 27, 45	11-462 154-55	102, 127	12-305 084-25	28
11-225 169-25	119	11-330 244-15	51	11-472 193-55	36, 89, 104	12-305 114-05	40, 50, 57, 75, 78, 91, 99, 106, 107, 109,111,114, 115
11-225 172-15	30, 109, 123	11-330 277-15	11, 32, 80	11-472 199-55	36, 89, 104	12-305 114-15	71, 129
11-225 175-15	31, 65	11-330 280-15	13, 38, 47, 90, 105	11-550 223-15	80, 84	12-305 144-15	40, 45, 52, 56, 91, 94, 95, 122, 124
11-225 175-25	25	11-330 283-15	11	11-560 190-15	129	12-305 144-25	62, 81, 82, 83, 125
11-225 178-15	107, 119	11-330 286-15	45	11-560 244-15	125	12-305 174-15	27, 38, 50, 52, 53, 56, 99,100
11-225 178-25	118, 125	11-330 304-15	99	11-724 190-55	75	12-305 221-15	64
11-225 184-15	28, 129	11-330 352-15	11	11-724 907-55	83	12-305 224-15	37, 38, 56, 57, 67, 99
11-225 196-15	50	11-330 364-15	39, 42	12-005 154-25	14, 112, 113	12-305 264-15	37, 39, 42, 43, 44, 51, 55, 93, 96, 97, 99
11-225 220-15	49	11-330 370-15	51	12-005 171-15	21, 28, 125, 129		
11-225 223-15	94	11-330 952-15	15, 16, 23, 26, 28, 31	12-005 195-15	19, 95		
11-225 223-25	84	11-330 955-15	29, 66	12-005 215-15	34, 56, 73, 75		
11-225 226-15	91, 110	11-330 956-15	125	12-010 240-15	79		
11-225 232-15	18, 38, 40	11-330 960-15	12, 15, 29, 31	12-024 121-15	112, 113		
11-225 238-15	39, 42, 84	11-330 962-15	13	12-024 121-25	79, 108, 117		
11-225 283-15	123	11-330 964-15	15, 28, 31				

No.	Seite Page Pages Página	No.	Seite Page Pages Página	No.	Seite Page Pages Página	No.	Seite Page Pages Página
12-305 314-15	37, 101	12-501 150-45	49	12-710 250-52	54	14-215 013-13	22
12-315 080-15	28	12-501 170-45	49, 52, 57	12-710 270-12	13	14-215 013-23	26
12-315 090-25	14	12-501 190-45	47, 52	13-030 530-05	33	14-215 022-33	18, 29
12-316 220-15	52	12-501 210-45	49, 51	13-030 635-05	11	14-215 028-23	27
12-322 028-05	18	12-501 230-45	47	13-030 641-05	11	14-215 073-13	23
12-333 230-15	11	12-505 171-15	49	13-033 004-05	28	14-215 091-13	13
12-335 151-15	41, 56, 57, 98, 102, 110	12-512 111-25	73	13-033 091-05	14	14-215 124-13	27
12-335 171-15	36, 89, 104	12-512 170-05	73	13-033 109-05	14	14-215 166-03	13
12-335 191-15	55, 95	12-512 220-05	73	13-033 262-05	119	14-215 199-23	27
12-335 191-25	103	12-517 250-45	39, 42	13-033 307-05	99	14-218 050-01	18, 39, 42
12-335 210-15	65	12-610 170-45	29	13-033 400-05	39, 42	14-218 090-01	18, 40
12-360 043-05	92	12-610 200-45	29	13-033 490-05	43, 44	14-280 090-01	23
12-360 061-05	29	12-610 210-45	13, 39, 42	13-033 553-05	54	14-310 240-01	96, 97
12-360 124-05	35	12-610 250-45	40, 91	13-033 568-05	17	14-602 901-01	16
12-360 141-05	45	12-610 270-45	99	13-052 046-55	29	14-650 251-05	31
12-360 143-05	45	12-610 310-45	13	13-052 247-15	56	14-680 420-15	31
12-360 181-05	53	12-610 330-45	53	14-010 665-01	99	14-731 451-05	45
12-360 184-05	53	12-610 380-45	11	14-016 101-91	31	14-731 634-05	125
12-360 220-15	52	12-610 570-45	96, 97	14-016 103-01	31	14-731 679-05	125
12-380 170-25	41, 56, 57	12-618 190-45	16	14-016 120-01	39, 42	14-731 915-05	43, 44
12-499 150-25	129	12-640 130-55	14, 16, 28	14-016 150-01	15	14-757 131-01	43, 44, 51, 55
12-499 150-45	57, 78, 106	12-640 170-55	22	14-016 151-91	15, 29	15-032 001-45	19, 21, 24, 128
12-499 170-45	40, 50, 91	12-642 901-55	116	14-018 594-01	45	15-032 002-45	63
12-499 190-45	38, 78, 99	12-642 902-55	115	14-018 614-91	28	15-032 006-45	14, 32, 122
12-499 210-45	70	12-660 430-45	39, 42	14-018 640-01	52, 53	15-120 707-05	29
12-499 230-45	39, 42, 43, 44, 51, 96, 97	12-660 520-45	43, 44, 51	14-018 644-91	15	15-120 718-05	29
12-499 250-45	51	12-660 550-45	39, 42, 52, 53, 99	14-026 122-01	29	15-120 902-05	29
12-499 290-45	47	12-710 150-12	125	14-027 902-01	118, 119	15-125 049-05	30
12-500 151-45	111, 115	12-710 190-02	88	14-031 081-01	40, 91	15-711 050-51	22, 91
		12-710 250-12	80	14-031 151-01	39, 42	16-040 010-11	28, 125

Index (Teilenummern / Seitenzahlen)

Index (part numbers / page numbers)

Index (numéros de pièces, de pages)

Index (números de pieza / números de página)

PFAFF 3588-05/020
PFAFF 3588-15/020
17

No.	Seite Page Pages Página	No.	Seite Page Pages Página	No.	Seite Page Pages Página	No.	Seite Page Pages Página
16-041 035-41	21	25-308 820-40	24, 54, 58, 59, 60, 61, 62, 79, 112, 113, 120, 121, 124, 127, 128	71-160 001-65	78	71-910 000-49	69
16-042 903-01	45			71-160 003-37	78, 99	71-910 000-50	76
16-047 020-15	82, 118, 119	25-308 820-60	58, 62, 127	71-160 003-38	68, 76	71-910 000-52	78
16-047 131-55	35			71-160 003-80	67, 76	73-061 015-91	73
16-049 020-11	82, 118, 119	25-405 604-11	109	71-160 008-14	66	73-071 008-91	65
16-409 970-05	15	25-405 604-12	109	71-190 000-60	73	91-000 250-15	29
16-409 971-05	23	25-405 604-33	109	71-190 001-18	73	91-000 390-05	29
16-414 127-05	31	25-901 610-03	66	71-190 002-13	73	91-000 529-15	29
16-920 007-15	43, 44	26-536 301-09	30	71-210 002-21	73	91-002 065-05	14
17-518 010-51	63	28-011 201-44	87	71-210 002-40	73	91-002 262-25	14
18-278 001-91	24	28-011 202-05	87	71-210 002-50	73	91 006 525-05	12
18-278 005-91	19, 21	28-011 202-10	87	71-210 002-52	73	91-006 526-05	12
18-279 010-05	128	28-011 202-43	87	71-370 001-31	44	91-010 183-05	14
18-372 001-91	24, 54, 59, 60, 61	28-011 202-47	87	71-370 001-33	114	91-010 937-05	14
18-372 004-91	62	28-911 200-42	109	71-370 001-36	120, 121	91-011 909-05	41, 56, 57
18-372 008-91	52, 54, 120, 121, 124	29-013 660-01	109	71-370 001-37	125	91-012 753-05	31
18-373 011-91	19	49-031 450-02	79	71-370 001-58	50	91-018 480-05	29
18-378 001-91	54, 55	70-371 500-02	50	71-370 001-59	69, 78, 99	91-020 086-15	28
18-378 004-91	62	71-110 004-21	67	71-370 001-75	69	91-021 624-05	94
18-378 008-91	107, 111, 115, 124, 128	71-120 005-32	50	71-480 000-12	73	91-022 116-05	50
18-378 009-91	30	71-120 006-32	20, 97, 118, 119	71-520 005-17	70	91-024 554-05	50
18-379 004-91	62	71-130 004-39	66	71-520 005-19	45	91-030 357-05	125
18-381 002-91	63	71-130 004-40	66	71-520 005-20	99	91-031 888-15	78
24-162 253-44	66	71-130 005-52	40, 44	71-710 000-82	73	91-056 192-25	14
25-161 801-49	30	71-130 006-42	102	71-750 002-46	71	91-056 193-25	14
25-161 801-52	17	71-140 000-41	35	71-750 002-76	70	91-056 578-91	16
25-161 805-04	63	71-150 000-69	73	71-750 002-96	73	91-056 760-05	14
25-308 820-30	12, 14, 19, 21, 25, 107, 114, 118, 119, 120, 121, 122, 124, 125, 128	71-160 001-39	68, 76	71-760 004-99	67	91-059 483-04/001	26
		71-160 001-40	99	71-890 000-14	64	91-059 483-04/002	26
		71-160 001-42	76	71-910 000-34	76	91-059 483-04/003	26

No.	Seite Page Pages Página	No.	Seite Page Pages Página	No.	Seite Page Pages Página	No.	Seite Page Pages Página
91-059 483-04/004	26	91-118 889-92	26	91-166 384-05	28	91-173 972-05	29
91-059 483-04/005	26	91-118 893-92	27	91-166 388-05	29	91-173 973-15	29
91-059 483-04/006	26	91-118 898-05	27	91-166 391-15	29	91-174 155-12	29
91-059 954-04/001	26	91-119 015-15	13	91-166 452-21	16	91-174 879-05	16
91-059 954-04/002	26	91-119 121-12	28	91-166 520-05	13	91-176 094-05	29
91-059 954-04/003	26	91-119 704-91	15	91-166 521-05	13	91-176 199-92	13
91-069 709-12	18	91-119 705-12	15	91-166 529-05	18	91-176 204-05	13
91-100 270-25	120,121,128	91-119 763-05	13	91-166 531-5	18	91-176 302-05	13
91-100 343-15	88, 118, 119, 122, 125	91-129 668-25	85	91-166 532-05	18	91-176 309-05	13
91-100 355-05	13	91-129 669-75/698	85	91-166 589-05	17	91-176 315-05	13
91-100 396-15	29	91-129 670-45	85	91-166 827-05	29	91-176 324-25	14
91-105 447-25	14	91-129 671-05	85	91-166 828-05	29	91-176 332-25	14
91-118 045-91	26	91-129 917-91	87	91-166 889-05	14	91-176 337-15	14
91-118 137-91	28	91-140 199-02	29	91-166 915-05	12	91-176 373-21	14
91-118 154-90	28	91-140 239-05	28	91-168 081-05	22	91-176 378-05	14
91-118 430-25	14	91-140 676-05	29	91-168 194-71/698	14	91-176 431-05	14
91-118 518-05	13	91-150 656-05	26	91-169 132-15	27	91-176 438-05	29
91-118 570-92	15	91-162 526-05	31	91-169 556-15	22	91-176 464-05	14
91-118 600-91	27	91-164 443-12	26	91-170 228-91	15	91-186 659-05	28
91-118 683-05	16	91-164 902-01	13	91-170 229-11	15	91-188 163-15	28
91-118 703-01	28	91-164 928-91	13	91-170 811-92	23, 31	91-188 539-02	29
91-118 704-05	28	91-164 930-91	13	91-171 049-05	16	91-229 070-70/895	85
91-118 707-92	28	91-166 034-01	12	91-171 875-12	18	91-264 357-05	16
91-118 709-15	28	91-166 037-15	12	91-172 676-05	23	91-264 358-05	16
91-118 711.05	28, 29	91-166 148-92	27	91-172 778-05	23	91-268 037-05	14
91-118 782-05	29	91-166 376-91	29	91-173 085-05	27	91-266 136-05	29
91-118 787-15	29	91-166 378-05	29	91-173 572-05	29	91-266 288-15	28
91-118 881-05	26	91-166 381-05	28	91-173 911-05	28	91-266 298-05	28
91-118 884-45	26	91-166 382-05	28	91-173 914-05	29	91-266 299-91	28
91-118 887-05	26	91-166 383-15	28	91-173 915-92	29	91-266 316-91	28

Index (Teilenummern / Seitenzahlen)

Index (part numbers / page numbers)

Index (numéros de pièces, de pages)

Index (números de pieza / números de página)

PFAFF 3588-05/020
PFAFF 3588-15/020
17

No.	Seite Page Pages Página	No.	Seite Page Pages Página	No.	Seite Page Pages Página	No.	Seite Page Pages Página
91-266 335-01	13	91-291 133-91	14	91-291 514-91	75	91-291 676-91	118, 119
91-266 353-05	14	91-291 362-93/001	75	91-291 515-91	73	91-291 702-91	122
91-266 359-05	28	91-291 482-91	70	91-291 516-05	73	91-291 704-91	120, 121
91-266 381-05	28	91-291 483-91	70	91-291 517-05	73	91-291 707-91	76
91-266 411-25	14	91-291 484-91	77	91-291 518-91	44	91-291 751-91	71
91-266 414-05	14	91-291 485-91	69	91-291 519-91	44	91-291 760-91	67
91-266 424-91	29	91-291 487-91	73	91-291 520-91	45	91-291 768-91	71
91-266 428-01	28	91-291 488-91	45	91-291 521-91	45	91-291 907-93/001	20
91-266 448-12	29	91-291 489-91	73	91-291 549-05	73	91-291 919-91	103
91-266 456-91	14	91-291 490-91	70	91-291 550-05	73	91-291 920-90	103
91-266 479-91	31	91-291 491-91	71	91-291 551-05	75	91-291 930-90	102
91-266 482-05	31	91-291 492-92	73	91-291 552-05	75	91-291 932-91	102
91-266 483-05	31	91-291 494-91	67	91-291 553-05	75	91-292 270-91	126
91-266 484-05	31	91-291 496-91	70	91-291 554-05	71	91-292 271-91	126
91-266 504-91	29	91-291 497-91	67	91-291 555-91	24	91-292 341-91	64
91-266 545-91	13	91-291 498-91	73	91-291 566-91	76	91-292 350-71/699	64
91-266 593-92	29	91-291 499-91	71	91-291 581-91	76	91-292 393-91	70
91-266 605-05	28	91-291 500-91	76	91-291 582-91	97	91-292 394-91	70
91-266 606-91	28	91-291 501-91	35	91-291 583-91	99	91-292 395-91	70
91-266 651-05	13	91-291 502-91	33	91-291 592-91	25	91-292 396-91	70
91-266 652-00	29	91-291 503-91	75	91-291 593-91	50	91-292 397-91	70
91-266 727-05	13	91-291 504-91	77	91-291 594-91	65	91-292 398-91	70
91-266 749-05	29	91-291 505-91	64	91-291 595-71/895	66	91-292 399-75/891	64
91-266 757-05	14	91-291 506-91	67	91-291 597-91	76	91-292 737-91	52
91-266 818-05	88, 125	91-291 507-91	68	91-291 630-91	40	91-292 738-91	52
91-280 078-75/895	11	91-291 508-91	68	91-291 631-91	40	91-292 739-91	51
91-280 218-91	29	91-291 509-91	76	91-291 632-91	40	91-292 740-91	54
91-290 112-91	70	91-291 510-91	68	91-291 647-91	68	91-292 741-91	54
91-290 577-91	70	91-291 511-91	73	91-291 650-91	68	91-296 120-91	65
91-290 732-91	70	91-291 512-91	63	91-291 674-45	73	91-700 249-15	28

No.	Seite Page Pages Página	No.	Seite Page Pages Página	No.	Seite Page Pages Página	No.	Seite Page Pages Página
91-700 335-25	41, 44, 118, 119	95-215 040-14/161	49	95-753 621-05	39	95-775 355-15	41, 56, 57
91-700 510-15	15	95-215 040-15/131	49	95-753 637-05	39, 42	95-775 356-15	41, 56, 57
91-700 689-15	26	95-215 040-15/381	44	95-753 638-05	39, 42	95-775 357-15	56, 86, 108, 117, 123
91-700 785-15	12	95-215 040-15/386	44	95-753 646-05	39, 42	95-775 360-15	112, 113, 117
91-700 996-15	16	95-215 040-18/505	49	95-753 650-91	39, 42	95-775 367-15	41, 57
91-701 344-25	79	95-215 070-05/901	47	95-753 651-91	39, 42	95-775 368-05	56
91-701 522-25	14	95-215 080-14/925	49	95-753 651-91	39, 42	95-775 369-01	123
95-215 000-00/635	47	95-215 080-17/604	49	95-753 696-05	40, 91	95-775 376-75/895	51
95-215 000-03/413	49	95-215 080-17/605	49	95-753 907-75/895	114	95-775 377-05	55
95-215 000-03/992	47	95-215 080-18/008	47	95-774 464-25	16	95-775 378-05	52
95-215 040-12/556	47	95-215 080-18/102	49	95-774 466-91	16	95-775 379-75/895	53
95-215 040-12/561	47	95-215 080-23/601	49	95-775 228-15	111, 115	95-775 380-15	54
95-215 040-12/569	49	95-215 080-29/013	47	95-775 229-25	107, 111, 115	95-775 381-91	52
95-215 040-13/534	49	95-560 274-75/940	68	95-775 258-71/895	57	95-775 382-71/895	53
95-215 040-13/535	47	95-633 660-91	63	95-775 259-71/895	56	95-775 383-71/895	51
95-215 040-13/591	47	95-711 645-11	129	95-775 311-15	45	95-775 387-15	53
95-215 040-13/877	47	95-714 813-05	80	95-775 320-91	25	95-775 391-15	51
95-215 040-13/878	47	95-746 180-05	51	95-775 322-05	25	95-775 392-15	51
95-215 040-13/880	49	95-753 342-15	66	95-775 324-05	40, 91	95-775 393-15	52
95-215 040-13/921	47	95-753 564-05	111, 115	95-775 327-05	40, 57, 91	95-775 394-15	30
95-215 040-13/923	47	95-753 577-05	40, 91	95-775 328-05	109, 123	95-775 397-15	55
95-215 040-14/132	47	95-753 578-75/893	39, 42	95-775 329-90	41, 56, 57	95-775 402-75/895	11
95-215 040-14/133	47	95-753 593-15	40, 91	95-775 331-75/895	57	95-775 403-75/895	11
95-215 040-14/134	47	95-753 594-15	40, 91	95-775 332-75/895	56	95-775 405-71/895	11
95-215 040-14/135	49	95-753 595-05	43, 44	95-775 340-71/895	45	95-775 414-92	22
95-215 040-14/136	47	95-753 596-15	43, 44	95-775 346-75/895	45	95-775 416-92	21
95-215 040-14/138	49	95-753 597-05	43, 44	95-775 347-15	45	95-775 421-91	15
95-215 040-14/141	47	95-753 599-11	37	95-775 349-15	45	95-775 422-91	15
95-215 040-14/143	47	95-753 606-05	40, 91	95-775 350-91	58	95-775 424-91	13
95-215 040-14/146	47	95-753 607-05	40, 91	95-775 351-91	60	95-775 425-01	13
		95-753 608-47	123	95-775 353-75/895	45		

Index (Teilenummern / Seitenzahlen)

Index (part numbers / page numbers)

Index (numéros de pièces, de pages)

Index (números de pieza / números de página)

PFAFF 3588-05/020
PFAFF 3588-15/020
17

No.	Seite Page Pages Página	No.	Seite Page Pages Página	No.	Seite Page Pages Página	No.	Seite Page Pages Página
95-775 427-05	11	95-775 489-05	21	95-775 534-91	38	95-775 580-04/160	107
95-775 428-05	32	95-775 490-05	23	95-775 535-01	39, 42	95-775 580-04/180	107
95-775 429-92	12	95-775 491-15	11	95-775 536-05	40	95-775 580-04/240	107
95-775 431-91	32	95-775 492-91	26	95-775 537-05	40, 91	95-775 580-04/260	107
95-775 433-05	19	95-775 493-71/951	27	95-775 538-05	40, 91	95-775 581-15	38
95-775 434-15	19	95-775 494-91	28	95-775 540-11	39, 42	95-775 582-15	38
95-775 435-92	18	95-775 495-05	17	95-775 541-91	39, 42	95-775 583-15	110
95-775 436-05	18	95-775 497-15	34	95-775 542-75/893	39, 42	95-775 584-15	110, 116
95-775 437-15	32	95-775 499-15	32	95-775 543-71/893	39, 42	95-775 588-05	111, 115
95-775 438-05	32	95-775 500-05	19	95-775 544-71/893	39, 42	95-775 589-91	107, 111, 115
95-775 441-15	11	95-775 501-75/893	43, 44	95-775 545-71/893	43, 44	95-775 591-05	111, 115
95-775 446-12	31	95-775 502-71/893	37	95-775 546-15	43, 44	95-775 594-15	110
95-775 447-91	24	95-775 504-05	43, 44	95-775 547-05	40	95-775 595-91	110
95-775 449-75/893	11	95-775 505-75/893	43, 44	95-775 548-05	40	95-775 606-71/893	37
95-775 467-92	11	95-775 506-75/893	43, 44	95-775 549-01	40	95-775 607-71/893	37
95-775 468-05	11	95-775 509-05	96, 97	95-775 550-05	40, 91	95-775 610-71/893	37
95-775 469-75/895	11	95-775 511-15	96, 97	95-775 555-75/893	37	95-775 612-55	37
95-775 470-05	32	95-775 512-05	43, 44	95-775 556-75/893	37	95-775 613-15	39, 42
95-775 471-05	32	95-775 513-05	39, 42	95-775 561-05	51	95-775 614-71/893	37
95-775 472-92	17	95-775 514-05	96, 97	95-775 569-05	36	95-775 620-15	39, 42
95-775 473-90	15	95-775 516-15	99	95-775 571-05	42	95-775 622-71/895	47
95-775 476-05	17	95-775 518-05	96, 97	95-775 572-05	39	95-775 644-71/895	50
95-775 477-91	32	95-775 520-91	96, 97	95-775 577-15	110	95-775 658-15	40
95-775 482-12	26	95-775 525-15	99	95-775 578-15	110	95-775 664-71/893	97
95-775 483-05	27	95-775 527-15	99	95-775 579-15	107	95-775 665-75/893	97
95-775 484-05	27	95-775 529-75/893	99	95-775 580-04/060	107	95-775 666-15	97
95-775 485-92	27	95-775 530-05	99	95-775 580-04/080	107	95-775 674-71/893	99
95-775 486-05	26	95-775 531-05	99	95-775 580-04/100	107	95-775 683-15	101
95-775 487-05	31	95-775 532-05	99	95-775 580-04/120	107	95-775 687-05	101
95-775 488-05	29	95-775 533-15	40, 91	95-775 580-04/140	107	95-775 688-25	80

No.	Seite Page Pages Página	No.	Seite Page Pages Página	No.	Seite Page Pages Página	No.	Seite Page Pages Página
95-775 690-05	36	95-775 791-15	38	95-776 015-91	98	95-776 300-05	80
95-775 695-71/895	37	95-775 792-11	38	95-776 025-05	80	95-776 304-71/893	106
95-775 696-75/895	80	95-775 800-91	14	95-776 042-91	64	95-776 326-92	80
95-775 699-75/895	82	95-775 823-71/895	17	95-776 060-15	43, 44	95-776 327-05	84
95-775 701-75/893	43, 44	95-775 851-75/893	100	95-776 062-05	36	95-776 351-71/893	38
95-775 708-91	123	95-775 880-05	98	95-776 063-05	36, 89	95-776 354-21	66
95-775 710-91	123	95-775 882-15	38	95-776 076-11	38	95-776 358-05	84
95-775 715-90	101	95-775 884-05	41	95-776 081-71/895	80	95-776 414-71/951	55
95-775 718-75/895	83	95-775 885-15	41	95-776 082-05	84	95-776 418-05	91
95-775 732-05	82	95-775 886-15	41	95-776 111-15	86	95-776 422-90	120, 121
95-775 733-05	83	95-775 905-15	35	95-776 128-15	108, 117	95-776 429-05	117
95-775 735-75/895	80	95-775 908-11	15	95-776 136-05	79	95-776 440-05	83
95-775 742-05	25	95-775 912-11	31	95-776 137-15	79	95-776 442-01	109
95-775 751-75/895	81	95-775 913-15	86	95-776 149-11	55	95-776 450-05	118
95-775 752-75/895	81	95-775 914-91	15	95-776 187-91	79	95-776 453-91	38
95-775 753-91	12	95-775 915-05	18	95-776 188-91	86	95-776 472-11	108, 112
95-775 757-05	109	95-775 917-05	21	95-776 189-15	86	95-776 473-11	108, 113
95-775 758-15	102	95-775 919-05	17, 33	95-776 190-05	46	95-776 505-91	22
95-775 763-04/060	107	95-775 921-11	33	95-776 196-91	86	95-776 506-92	22
95-775 763-04/080	107	95-775 929-71/698	14	95-776 211-15	40	95-776 507-05	22
95-775 763-04/100	107	95-775 930-25	14	95-776 233-04/001	122	95-776 508-05	22
95-775 763-04/120	107	95-775 931-11	23	95-776 233-04/002	122	95-776 509-92	22
95-775 763-04/140	107	95-775 934-11	15	95-776 233-04/003	122	95-776 510-05	22
95-775 763-04/160	107	95-775 937-25	14	95-776 233-04/004	122	95-776 511-05	22
95-775 763-04/180	107	95-775 939-91	14	95-776 233-04/005	122	95-776 512-05	22
95-775 763-04/240	107	95-775 940-01	30	95-776 240-05	122	95-776 513-05	22
95-775 763-04/260	107	95-775 941-05	30	95-776 276-05	118, 119	95-776 516-05	120, 121
95-775 764-71/895	37	95-775 942-91	21	95-776 296-71/893	66	95-776 519-90	109
95-775 776-05	82	95-775 943-91	19	95-776 298-71/893	66	95-776 535-70/895	123
95-775 777-75/895	81	95-775 945-91	24	95-776 299-05	38	95-776 537-05	123

Index (Teilenummern / Seitenzahlen)

Index (part numbers / page numbers)

Index (numéros de pièces, de pages)

Index (números de pieza / números de página)

PFAFF 3588-05/020
PFAFF 3588-15/020
17

No.	Seite Page Pages Página	No.	Seite Page Pages Página	No.	Seite Page Pages Página	No.	Seite Page Pages Página
95-776 540-05	123	95-778 169-05	104	95-778 424-15	56	95-778 496-01	125
95-776 559-15	78	95-778 170-05	104	95-778 428-05	90	95-778 497-15	125
95-776 560-15	78	95-778 171-05	104	95-778 429-05	90	95-778 498-15	125
95-776 561-15	78	95-778 173-05	104	95-778 430-91	91	95-778 502-05	127
95-776 562-05	123	95-778 175-91	14	95-778 436-05	124	95-778 503-05	125
95-776 563-05	123	95-778 182-91	20	95-778 444-05	124	95-778 504-05	128
95-776 564-05	123	95-778 191-05	91	95-778 445-05	90	95-778 505-05	125
95-776 566-90	114	95-778 192-05	91	95-778 446-05	89	95-778 509-05	109
95-776 629-15	129	95-778 215-75/895	57	95-778 447-05	89	95-778 510-90	109
95-776 630-15	129	95-778 220-05	129	95-778 448-75/895	94	95-778 511-05	29
95-776 631-71/895	129	95-778 222-05	129	95-778 449-15	94	95-778 581-15	52
95-776 633-90	123	95-778 223-15	129	95-778 450-75/893	93	95-850 315-15	115
95-776 695-05	112, 113	95-778 224-05	129	95-778 452-71/893	95	95-850 316-15	115
95-776 701-15	92	95-778 236-05	91	95-778 455-05	89	95-850 560-15	110
95-776 722-15	112, 113	95-778 237-05	91	95-778 460-05	125	95-850 633-05	119
95-776 723-15	112, 113	95-778 249-05	91	95-778 461-05	125	95-850 658-05	117
95-776 754-05	112, 113	95-778 282-05	13	95-778 463-05	125	95-850 737-05	118, 119
95-776 755-11	112, 113	95-778 296-15	84	95-778 464-75/893	125	95-851 045-15	110
95-776 761-91	118, 119	95-778 374-91	14	95-778 465-05	125	95-851 045-91	110
95-776 765-05	118, 119	95-778 386-75/895	84	95-778 467-15	45	95-851 084-15	116
95-776 766-05	118, 119	95-778 387-05	84	95-778 470-71/893	90, 105	95-851 313-91	110
95-776 767-05	118, 119	95-778 412-05	65	95-778 475-05	105	95-851 496-15	110
95-776 768-05	118, 119	95-778 413-05	12	95-778 476-15	45	95-852 436-15	116
95-776 769-05	118, 119	95-778 414-04	91	95-778 480-01	89	95-853 178-91	110
95-776 770-05	118, 119	95-778 415-15	90	95-778 481-91	105	95-853 179-15	110
95-778 009-05	115	95-778 416-15	90	95-778 484-75/893	124	95-853 238-15	110
95-778 010-91	115	95-778 417-05	90	95-778 485-05	125	95-853 238-91	110
95-778 089-05	12	95-778 419-11	52	95-778 486-05	125	96-100 419-02	65
95-778 125-75/895	13	95-778 422-05	52	95-778 489-01	125	96-700 175-15	21
95-778 162-15	86	95-778 423-15	56	95-778 491-91	88	96-701 212-92	21

No.	Seite Page Pages Página	No.	Seite Page Pages Página	No.	Seite Page Pages Página	No.	Seite Page Pages Página
99-115425-91	114	99-135 431-91	63	99-136 873-91	111, 115	99-137 486-91	125
99-115 453-91	43, 44	99-135 490-91	14, 19, 25, 32, 107, 125	99-137 005-15	109	99-137 958-91	51
99-115 505-91	24, 52, 59, 60, 61	99-135 496-95	54, 60, 61, 114	99-137 077-91	24	99-137 959-91	51
99-133 127-91	54	99-135 549-91	79	99-137 079-05	11	99-137 961-91	51, 54
99-133 283-15	27	99-135 556-91	62	99-137 085-91	40	99-137 962-91	55
99-133 646-01	127	99-135 601-91	19, 34, 124	99-137 086-91	43, 44	99-137 963-91	52
99-133 753-91	122, 125	99-135 613-91	107, 127	99-137 087-05	96, 97	99-137 964-91	52
99-133 920-91	30	99-135 617-95	54, 62, 79	99-137 146-91	52	99-137 966-91	54
99-133 962-91	45	99-135 809-91	34	99-137 147-05	52	99-137 967-91	54
99-134 206-05	25, 114, 120, 121, 128	99-135 818-05	60, 107	99-137 148-05	52	99-137 968-91	52
99-134 207-05	14	99-135 819-05	60, 107	99-137 151-45	16		
99-134 255-91	114, 120, 121, 128	99-135 835-05	114, 120, 121, 128	99-137 169-91	107		
99-134 256-91	112, 113, 118, 119, 122	99-135 845-91	21	99-137 170-91	63		
99-134 296-45	23	99-135 873-05	127	99-137 171-91	86		
99-134 299-91	28	99-135 874-05	127	99-137 172-91	57		
99-134 421-91	28, 112, 113, 125	99-135 886-05	127	99-137 174-91	78		
99-134 586-91	78	99-135 911-91	25, 28, 107, 122, 124	99-137 181-91	24		
99-134 594-71/893	37, 66	99-136 009-75	84	99-137 182-91	45		
99-134 815-91	37	99-136 071-95	122	99-137 185-95	24		
99-134 850-91	45	99-136 072-95	62	99-137 200-05	78		
99-134 851-91	24	99-136 205-91	54, 124	99-137 206-91	36, 89, 104		
99-134 935-91	37, 96, 97	99-136 220-91	79, 119	99-137 229-91	122		
99-134 960-91	21	99-136 235-91	32, 125	99-137 269-91	58, 60, 120, 121		
99-135 002-95	19, 107, 118, 119	99-136 310-05	127	99-137 270-91	58, 60, 128		
99-135 066-91	14	99-136 345-91	37	99-137 271-91	60		
99-135184-91	118, 119	99-136 396-91	28, 30	99-137 327-91	45		
99-135 233-91	21, 25, 125	99-136 409-91	30	99-137 352-91	124		
99-135 298-91	51, 112, 113	99-136 585-95	36, 81, 84, 89, 104	99-137 363-91	52		
99-135 353-91	60, 124	99-136 590-01	52	99-137 426-91	127		
99-135 354-05	127	99-136 846-91	101	99-137 469-91	91		



Europäische Union
Wachstum durch Innovation – EFRE



PFAFF Industriesysteme und Maschinen AG

Hans-Geiger-Str. 12 - IG Nord
D-67661 Kaiserslautern

Telefon: +49-6301 3205 - 0
Telefax: +49-6301 3205 - 1386
E-mail: info@pfaff-industrial.com